



**TECHNICIAN TRUSTED.  
INDUSTRY RESPECTED.**

**PRODUCT CATALOG**



**scceusa.com**

(855) 999.SCCE

# SOUTHERN CALIFORNIA COLLISION EQUIPMENT



## TRUSTED BY THE AUTO BODY REPAIR COMMUNITY

Southern California Collision Equipment was founded in 2010 by Chris and Ian Stoffel with a mission to provide premium collision equipment that enhances work efficiency for mechanics and technicians nationwide. Our team at SCCE, all Discover Leadership Master graduates, are committed to delivering comprehensive, high-quality equipment for precise repairs. With over a decade of experience, we've built a reputation for exceeding customer expectations while maintaining the highest standards of integrity.

SCCE is the trusted provider and advisor for mechanics and technicians, offering the tools and expertise needed to meet all your collision equipment needs.



**DISCOVER**  
LEADERSHIP TRAINING™

## CUSTOMER-CENTRIC. RELIABLE. LOYAL.

### WE'RE HERE TO SERVE YOU

In addition to incredible service, we're here to support you even after you've found the equipment you need. We provide maintenance and repair services to help keep your equipment in top shape. To learn more about our maintenance and repair service, call us at 855-999-SCCE.

# AREAS WE SERVE



**CALL US TODAY**



**FOR THE BEST  
EQUIPMENT &  
SERVICE!**

**(855) 999.SCCE**

# OUR PARTNERS



# OEM CERTIFICATIONS

At Southern California Collision Equipment, we are committed to ensuring our customers achieve OEM certification. Our team works diligently to provide the highest quality collision repair equipment and support, making it easier for shops to meet rigorous manufacturer standards. We understand the importance of staying up-to-date with the latest technologies and certifications, and we are dedicated to helping every customer reach their goals with confidence and excellence.



# TABLE OF CONTENTS

## Computerized Measuring and Blueprinting

- Meridian Live Mapping System
- Truscan Live Mapping System
- Eagle
- NAJA 3D

## ADAS Systems

- MAXISYS MA600 Portable ADAS System
- Autel MaxiSYS IA700
- IA800 Optical ADAS Positioning System
- Autel IA900 ADAS Calibration System
- Bosch ADAS Master Recalibration Solution
- Rotary MCS ADAS Diagnostic Solutions

## Diagnostic Tools and Accessories

- Autel Maxisys
- Maxim IM608PROIIPKA
- Maxibas BT609
- MaxiCharger AC Elite Home 50A - EV Charger with In-Body Holster

## Wheel Service

- Rotary 1090 Alignment System
- Rotary R1200 Tire Changer
- R180 3D Automatic Car and Truck Tire Balancer

## Frame Repair

- Chief Phoenix Pulling Rack
- Smart Rhone
- Rhone XL
- Rhone 4.2T
- Rhone L 4.2T
- Sevenne
- Sevenne XL
- Griffon
- Griffon VB
- Griffon XL
- X-TRAC Standard
- X-ONE Entry
- Evolution Systems
- Koala Pulling Rack
- Global Jig X-Pull
- Super Rotax

## Frame Rack Accessories/ Toolboards

- F.A.S.T Universal Adaptors
- F.A.S.T Anchoring
- Structural Holding Package
- Deluxe Chain & Clamp
- Auxiliary Pulling Packages
- Cameleon Premium

## Welding

- MI300T - Spot Welder
- MI200T - Spot Welder
- MULTIMIG 525 - Aluminum Welder
- MULTIMIG 522 - Aluminum Welder
- MULTIMIG 511 - Aluminum Welder
- M240 - Synergic Mig Welder
- MULTIMIG 822 - Three Phase MIG/MAG Welder
- Welding Helmets

# TABLE OF CONTENTS

## Collision Center Tools

- Lift King Light Duty
- Lift King Heavy Duty
- Lift King Combo
- Lift King Paint Accessories
- Lift King Lift Accessories
- Vulcan Adhesive Debonding Unit
- Heavy-Duty Riveting Tool
- Rivet Gun
- Tool Kit PNP 90 XT2
- Glenair Ground Rivet Tool
- Battery Riveting Machine ER20
- Milwaukee Tool M18 FUEL 1/4" Rivet w/OK Kit
- RV700 9 Ton
- RV/EP02 9 Ton
- GYSPRESS 10T
- GYSPRESS Workstation 10T Push-Pull Control
- 5T Power Gun
- MotionLED Estimator Light
- MotionLED & Extension Arm
- GUNIWHEEL Fast Puller XL
- Fume Dog Portable Weld Fume Extractor
- Portacool Fans
- Dent Fix Body Buggy - 4 Foot
- GuniWheel
- Mobile Dolly Station w/ 4 Dollies
- PR1 Parts Cart
- Goliath Weld Test Stand
- Goliath G1A Go Cart
- TGO-DC2 "ADAS" Calibration and Scanning Cart
- Inventory Control Units
- Dry Ice Energy Champ Turbo Pro
- Dry Ice Energy Champ Vario

## Panel Repair

- Flatliner Business System
- ALU Slimliner
- T-Hotbox Magic Wand Set
- Alu T-Hotbox (Aluminum)
- MultiTool Workstation With M30
- MultiTool Workstation With M35
- PRO Kit GYSPOT 34.02

## Plastic Welder

- Polyvance Plastic Welders
- 8203 Nitro-Fuzer Nitrogen Plastic Welder & Accessory Kit
- BETAG Plastic Fusion Pro Station

## Thermodyry Technology

- TD3 Pro

## AC Equipment

- Rotary R3AC80
- Robinair Connected R-1234YF ACS Machine
- Robinair WIFI AC RRR Machine R-134A
- MX1234
- MX3030

## Lifts

- Forward Lift I10 Two Post Lift
- Forward Lift EFP8
- Forward Lift EFP9 Four Post Lift
- Rotary SP010
- Rotary SP012
- Rotary SP016
- Rotary LT33A
- RT30 Service Repair Table
- BATPRO
- CarTar e-Glidemaster
- Rolling EVO
- CMO Air Rise 5
- CMO UTP
- CMO Spider Rolling Lift

# TABLE OF CONTENTS

## Glue Pulling

- Speedline Glue System
- Speedline Pro Station
- Speedline Eco System
- Speedline Accessory Kit

## Vacuum Systems

- Eurovac II - Pneumatic Sanding Portable
- Eurovac Explosion-Proof Portable
- Eurovac II Wet Mix Dust Collector

## Compressors

- Werther KV 5.5-20 HP Rotary Screw Compressors
- Prevost Airlines

## Paint

- Guns
- Masks
- Accessories

## Hand Tools

- Grip-On
- Oblong Hole Punch
- Hot Air Gun
- Polishing Machines
- Angle Grinder
- Pneumatic Pistol Grinder
- Rechargeable Drill
- Spot Weld Removal Tool
- Orbital Sander
- Torque Wrench

## Shop Tools

- Hydraulic Press
- Engine Hoist
- Axle Stands
- Hydraulic Floor Jack
- Fuel Retrieval and Storage System
- Battery Charger
- TOPDON BT600



# COMPUTERIZED MEASURING AND BLUEPRINTING



**CALL US TODAY**

**FOR THE BEST  
EQUIPMENT & SERVICE!**

(855) 999.SCCE



PRECISION COLLISION REPAIRS START WITH

# MERIDIAN™

CHIEF'S REVOLUTIONARY  
LIVE MAPPING™ MEASURING SYSTEM

The foundation of any quality repair is accurate measuring and Chief is dedicated to providing the equipment you need to get every job done right. Your customers rely on you for accurate and timely repairs. So, CHIEF engineers have used the best technology to deliver a Live Mapping™ system that's more accurate, more robust, and easier to use than any before. The completely redesigned GALILEO™ multi-point laser scanner combined with our all new real time measuring interface makes this system the industry's most accurate. Simply place the scanner under the vehicle, select the vehicle you are working on, place the targets where shown and you are ready to go.



**MERIDIAN**  
LIVE MAPPING SYSTEM™

Get a real-time, Live-Mapping™ picture of every stage of the repair with MERIDIAN™. Hang targets once to get a multi-point, full picture measurement of the entire vehicle's damage for more accurate estimates. GALILEO™ locks in 45 pre-defined high-tech targets in real time. You can even measure out of level - so there's no need to tie up a frame rack - delivering precise reports faster, every time.

MERIDIAN™ means faster frame measuring, better estimates and precision repairs. Find any hidden damage during the scan, make more inclusive repair plans, increase profit and reduce repeat visits. This proprietary software identifies incorrect pull set ups before they are made, preventing additional damage and speeding up the total repair process. Our exclusive best-in-class specification repair data ensures that vehicle measurements are up-to-date. CHIEF's measuring products are OEM-certified and report the exact condition of the vehicle frame before, during and after repairs. This provides the evidence of the total vehicle damage and the high quality of the finished repairs.

**PRODUCTS, TRAINING and UNRIVALED SUPPORT.**

NOTHING ELSE IS A  
**CHIEF**®

## INTRODUCING GALILEO™

CHIEF's NEW self-leveling multi-point laser scanner  
- delivering on the money reports each time, every time.

The new GALILEO™ scanner's robust construction features aerospace materials and thermal resistant technology for increased durability and long life, even in harsh shop environments. Its single-hub design delivers a 360° view, minimizing target blockage allowing for an even faster setup and large field of view.



### GALILEO FEATURES:

- Dual processors for fast real-time data processing
- Advanced optical components for accurate readings under any lighting
- Gorilla Glass® for added scratch protection
- Built-in calibration check allowing for easy technician verification

### HIGH POWERED LASER

The scanner utilizes high powered laser technology which insures outstanding performance. Its state-of-the-art optical path increases measurement length up to 5M.

### STABLE, OUT OF LEVEL MEASURING TECHNOLOGY

The geospatial control system makes necessary adjustments providing precise measurements no matter what direction the scanner is tilted. Out of level measuring allows the system to be moved from a 2-post lift for blueprinting to a frame rack or bench for structural repair in minutes without complicated set up. The revolving assembly's special design creates a stable perfect plane.

### CONSISTENT AND RELIABLE: IT OUT PERFORMS ALL OTHERS!

High resolution geospatial design and micro-rotational technology create precise, consistent speed while measuring and calculating more simultaneous reference points than any other system. High tech targets eliminate distortion and read all frame types delivering deadly accurate frame measurements each time, every time. GALILEO™ can be left in place during repairs to monitor dimensional changes AS THEY OCCUR for faster, higher-quality repairs. There is never a need to recalibrate after every pull.

### EASY-TO-USE OPERATION

1. Position the GALILEO™ scanner under the vehicle
2. Pull up detailed frame specifications for the vehicle being repaired
3. Hang the attachments and targets as instructed by MERIDIAN's tutorial
4. Watch as MERIDIAN shows you not only where the vehicle frame is out of alignment but also by how much and in what direction.



## MERIDIAN™ STEEL CABINET WORKSTATION

Chief's computerized measuring tools are far and away the most sophisticated, yet simple to learn and operate system available in the industry today.

### Lockable Steel Cabinet Workstation

- Durable, powder-coated frame structure
- Secure body scanner storage drawer
- Lockable - secure computer and printer cabinet storage
- Two rotating casters and two fixed casters
- Complete 110-volt or 220-volt system



### Software

- Exclusive Chief software that is quick and easy to navigate
- On-screen photos of recommended targets and attachments, and where they should be placed
- Comparative SAI and Caster measurements
- Automatically calculates for removed components
- Incorporate your company logo into printout design
- Includes FREE interactive help and tutorial



### Hole Attachments and Clips

- Magnetic hole attachments for fast and easy positioning
- Wide array of sizes from 10mm-25mm

### Bolt Attachments and Clips

- Magnetic bolt attachments ranging from 10mm-25mm
- Threaded bolt attachments ranging from 10mm-32mm
- Metal clip attachments ranging from 10mm-35mm



### Dual, High-Definition Flat Screen Monitors

The secondary web enabled monitor can run an estimating system or access your OEM repair procedures - technicians never have to leave the bay!



### Targets

- 45 individual bar-coded reflective targets for simultaneous multiple-point measuring
- Sleek design and variable lengths allow for easy viewing of multiple targets... even on large pick-ups and SUVs
- Protective end caps help prevent damage for prolonged life



### Target Extensions

Handy extensions attach to your existing targets, making them longer and allowing you to measure around underbody obstructions.

Part #798440

### Laser Body Scanner Storage

Easy-to-reach drawer securely stores scanner protecting it when not in use.



### Real-Time Measuring with Upper Body Bar Package

Measure the vehicle's strut towers and frame at the same time during pulls for higher-quality and faster repairs.

- Measure SAI and Caster
- Strut towers and fender bolts
- Generate comparison measurements for roof when optional extensions are used
- Generate comparison measurements for deck lid openings
- Generate comparison suspension angles when ball joints and strut towers are being measured

Part #788013D



### Computer

- Windows 10 Professional Edition / Required
- Heavy-duty CPU with Extreme Graphics, DVD player and 6-Channel high-output audio system
- Hyper-threading feature allows multiple programs to run simultaneously without slowing either program
- Stored safely in cabinet bottom
- Integrated Wi-Fi and BLUETOOTH functions

### Color Printer

- High-speed, high-resolution color printer is stored in cabinet bottom

Customize your measuring system into a comprehensive vehicle repair center. Optional innovative software and accessories quickly measure and document the dimensional condition of frames, body openings, and upper body openings. Create print documentation for customers and insurance companies of the high quality of your repairs.

## AUTO SCAN

### Profit-Boosting Software

Chief's AutoScan<sup>®</sup> and Estimator Pro-V<sup>®</sup> software, which provide more revenue generating opportunities that customers will appreciate and that will save considerable time during the front-end inspection and estimating process.

### Precision Specifications

MERIDIAN uses Chief Thunderbolt specs, which feature frame data for thousands of domestic and import cars and trucks from the present back to 1994, as well as Upper Body Opening data including doors, windows, hatches and strut towers. Chief specs have more vehicles than anyone else, and measures every vehicle personally with frame anchored and the suspension unloaded to provide you with "real world" accuracy other specs can't match.



### Intelli-Tape™

This optional system allows you to quickly measure body openings and point-to-point distances. This data is wirelessly transmitted to your system, instantly populating the correct fields and enabling you to produce printed color documentation of your findings.

Part #787071



### E-Access<sup>®</sup> On-Line Tech Support

E-Access<sup>®</sup> allows you to contact Chief's Tech Support team whenever you need assistance. Our experienced tech's can help you work through tough repair questions and can even take over your system, if asked to, to help you make sure the repairs are right the first time.



### Rear Wheel Tracking Gauge

Check and verify rear wheel tracking, offset, toe and length from body zero line. Measurements are automatically displayed on your monitor screen, and helps find and correct alignment issues before reassembly.

Part #702210



### Absolute Proof

Reinforce trust between you and insurance providers and generate more insurance-related business for your shop. Final inspection reports prove repairs were needed and returned the vehicle to pre-collision condition. This proof of high-quality repairs generates more repeat and referral business.



# CHIEF TRUSCAN™

**LIVE MAPPING™ MEASURING SYSTEM  
FAST SET UP. EASY TO OPERATE.**

## ACCURATE AND AFFORDABLE

All the capabilities you need, at a price that will make you wonder why you've waited so long. Spend less time training and more time making money with this accurate and affordable system. TRUSCAN™ integrates the precision of the NEW GALILEO™ laser scanner with LIVE computerized measuring for unmatched accuracy in collision repair and analysis before, during and after repairs.

## MEASURE LIVE DURING REPAIR

GALILEO™ can be left in place during LIVE repairs continuously monitoring entire vehicle during changes AS THEY OCCUR for increased speed and accuracy. No more pulling and measuring, then pulling again. This laser technology is never affected by outside influences like noise, air movement or light. The result is the most precise and accurate measuring available.

## INDIVIDUALLY CODED TARGETS

Chief targets use time tested scan technology and eliminate any distortion caused if the target is slightly angled. Recessed faces help prevent damage for prolonged life.

## PRECISION SPECS

TRUSCAN™ uses OEM-certified Thunderbolt™ specs, which feature frame data for thousands of domestic and import cars and trucks from present back to 1994, as well as Upper Body Opening data including doors, windows, hatches and strut towers. TRUSCAN's final report illustrates needed work was completed properly, proves vehicle has been returned to pre-collision condition and reinforces the trust between your shop and the insurance provider.



## TRUSCAN OPTIONAL ACCESSORIES

### Upper Body Bar with Stabilizer

Measure the vehicle roof, trunk, or even two strut towers at once. Included stabilizer eliminates out-of-level/sway issues for accurate readings every time.

Part No. 788452



### Vertical Scale Assembly

Attaches to the Upper Body Bar to allow measurement of vehicles with tall strut and/or underhood areas.

Part No. 797786



### Target Weight Assembly

Attach directly to the bottom of your targets to eliminate target sway.

Part No. 792024



### Drawer 4 Targets

Allows measurements on the vehicle frame — even the biggest pickups and SUVs.

Part No. 799535



### Target Extensions

Handy extensions attach to your existing targets, making them longer and allowing you to measure around underbody obstructions.

Part No. 798440



### Vertical Surface Attachment

Allows you to make comparative vertical measurements on upper body openings like doors and windows.

Part No. 799811



### Intelli-Tape

Quickly and accurately record and transmit upper body and point-to-point measurements. Measures underhood points, doors, windows, hatches, trunks and much more.

Part No. 787071



## TRUSCAN EQUIPMENT PACKAGE



### Steel Cabinet Workstation

Durable, powder-coated baked finish  
High-definition flat-screen monitor  
Two rotating casters and fixed casters  
Complete 110-volt or 220-volt system



### Computer

Windows® 10 Professional Edition

### Printer

High-resolution color printer



### Body Scanner With Frame Tray

Compact design reduces target blockage and improves line-of-sight, allowing more reference points to be measured

Scanner shown on cabinet shelf



### Targets

32 individual bar-coded reflective targets for simultaneous multiple-point measuring  
Recessed faces for protection

### Bolt Attachments / Clips

Metal style attachments  
Clip-on bolt heads ranging in size from 10mm to 35mm

### Hole Attachments / Clips

58 aluminum snap-in attachments ranging in size from 10mm to 32mm  
Side hole clips ranging in size from 23mm to 35mm



### Software

One-touch movements  
X-measurements can be made with one mouse click  
On-screen photos of attachment placement  
Comparative SAI and caster measurements  
Calculates for removed components  
Color reports to show measurements before, during and after repairs  
Your company logo can be incorporated into documents  
Interactive help and tutorial

### Literature

Users Manual, Parts Manual, Basic Training Manual  
Manuals for computer, printer and Microsoft® Windows  
Available on CD

## 3D ELECTRONIC MEASURING SYSTEM

HIGH DEFINITION LASER - HDL

**REF NO: EAGLE01.104**

Shoots the target in milliseconds and the measuring results are displayed in the software.

The all new 3D laser measurement system with self learning user interface.

The car body measurements can be carried out much more accurately with laser measurement system, compared to traditional technology.

- ⊕ Online 3D software for vehicle database
- ⊕ Wireless connectivity between the Laser gun, Targets and Software - WiFi technology
- ⊕ Unlike traditional technology, EAGLE does not require reference points measurement
- ⊕ Leveling of the vehicle is not required in EAGLE - PATENTED TECHNOLOGY
- ⊕ Ideal for Insurance diagnosis report - Complete vehicle body measurement in less than 10 minutes
- ⊕ Accuracy: +/- 0.5 mm
- ⊕ Original data from OEM



## 3D ELECTRONIC MEASURING SYSTEM

HIGH DEFINITION LASER - HDL

REF NO: EAGLE01.104

The screenshot displays the Eagle 3D Electronic Measuring System interface. At the top, a navigation bar includes icons for Menu, Car, BMW | 6 Series | 2018 - Present | 6 G32, Mode, ES1-0000, Battery, Points, and Report. The main area shows a 3D model of a car chassis in a rear view, with the word "REAR" at the top and "FRONT" at the bottom. The chassis is marked with numbered points: 6, 5, 19, 20, 25, 26, 74, 76, 75, 79, 80, 77, 39, 47, 48, and 78. A calibration instruction box on the right reads: "Calibration (1/3) Select a blue point and attach the Eagle head to it". Below the chassis, a control bar contains buttons for PERSPECTIVE, TOP, LEFT, RIGHT, FRONT, and REAR. On the far right, a vertical toolbar includes buttons for RESET, SAVE, and LOAD.

## USER INTERFACE OF EAGLE

# NAJA 3D

COMPUTERIZED MEASURING SYSTEM TO DIAGNOSE, REPAIR  
AND RE-MANUFACTURE

REF NO: NA.3024WI | NA.3025WI | NA.3026WS

3D Electronic measuring system is one of the worlds most advanced and user-friendly measuring system in this industry. Celette has been well known for its constant endeavors to provide the best in class collision repair systems and diagnostic equipment to the car manufacturers and to the end user. We not only provide equipments but also offer technical solutions.

- ⊗ Wireless bluetooth between the computer and the sliding head
- ⊗ User-friendly software for very easy use
- ⊗ No risk of faulty reading with green and red symbols (green for good and red for faulty)
- ⊗ High accuracy and reliability upon NF X06044 EUROPE-USA standard
- ⊗ Customer measurement, report, can be recorded and printed
- ⊗ Calibration check bar included for ISO process
- ⊗ Vehicle data supplied (comparative and point-to-point data)



**CELETTE** **GAZELLE**  
*Diagnostic*

# NAJA EVOLUTION 3D



NA.7020.4512



NA.3320



NA.3051



9105.503



NA.3102



GR97.0040



9105.063



NA.3026WS



NA.3025WI



NA.3024WI

REF NUMBER	DESCRIPTION
NA.3026WS	MEASURING SYSTEM NAJA
NA.3025WI	MEASURING SYSTEM NAJA + STORAGE TROLLEY FOR LAPTOP
NA.3024WI	MEASURING SYSTEM NAJA + STORAGE TROLLEY FOR DESKTOP
REF NUMBER	OPTIONAL ACCESSORIES
NA.3320	MAGNETIC SOCKET
NA.7020.4512	LATERAL PROBE
NA.3051	GAZELLE: LOWER SUPPORT STAND
9150.503	HOLDING ARM FOR NAJA
NA.3102	GAZELLE: NAJA SUPPORT FOR DIAGNOSTIC OPERATION
GR97.0040	PLIERS HIGH
9105.063	HOLDING DEVICE FOR PULLING OPERATION





# ADAS SYSTEMS



**CALL US TODAY**

**FOR THE BEST  
EQUIPMENT & SERVICE!**

(855) 999.SCCE

# ADAS CALIBRATION MA600

## AUTEL MAXISYS™

Tablet not included. The MA600 is compatible with the following tablets: MS906BT, MS906TS, MS908, MS908P, MS908S, MS908SP, MSELITE and MSADAS. All tablet models require an additional one-time purchase software application upgrade, except MSADAS. Tablets with previously active ADAS application software will not be compatible with MA600.



**ADJUSTABLE HEIGHT - STABLE FRAME BASE**

- CALIBRATE IN MULTIPLE LOCATIONS
- SIMPLE SETUP FOR TRANSPORTATION
- TRAVEL CASE FOR SECURE HANDLING



**TWO LINE LASER / FIVE LINE LASER**

- LASER ASSISTED FRAME PLACEMENT
- QUICKER FRAME CENTERING PROCEDURE
- ONE PERSON SETUP IN AS LITTLE AS 2 MINUTES

**TARGETS INCLUDED**

<p>Honda-LDW (CSC0601/08-L) Honda-LDW (CSC0601/08-R)</p>	<p>Volkswagen-LDW (CSC0601/01)</p>	<p>Mercedes-LDW (CSC0601/02)</p>
<p>Honda-LDW (CSC0601/05)</p>	<p>Hyundai / KIA-LDW (CSC0601/09)</p>	<p>Mercedes-LDW (CSC0601/19)</p>
<p>Toyota / Lexus-LDW (CSC0601/11)</p>	<p>Hyundai/KIA-LDW (CSC0601/07)</p>	<p>Nissan-LDW (CSC0601/03-L) Nissan-LDW (CSC0601/03-R)</p>
<p>Toyota-LDW (CSC0601/15)</p>	<p>Mitsubishi-LDW (CSC0601/22-L) Mitsubishi-LDW (CSC0601/22-R)</p>	<p>Nissan / Infiniti-LDW (CSC0601/06-L) Nissan / Infiniti-LDW (CSC0601/06-R)</p>
<p>Mazda-LDW (CSC0601/12)</p>	<p>Subaru-LDW (CSC0601/14)</p>	<p>Nissan-LDW (CSC0601/04-L) Nissan-LDW (CSC0601/04-R)</p>
<p>Mazda-LDW (CSC0601/13-L) Mazda-LDW (CSC0601/13-R)</p>		

**LATEST OE-LEVEL COVERAGE FOR US, ASIAN & EUROPEAN VEHICLES**

FLEXIBLE LDW TARGET/PATTERN CONFIGURATION WITH ILLUSTRATED STEP-BY-STEP INSTRUCTIONS

# Autel MAXISYS IA700

ADAS All-Systems Calibration System with MS909 Tablet: Alignment Pre-Check + All Systems ADAS.



The IA700AST package includes the IA700 frame with a robotic crossbar with six high-resolution positioning and tracking cameras, enabling fast and accurate target positioning and prompting unlevel floor compensation. The package features a MaxiSYS MS909, an advanced diagnostics tablet with a wireless VCI and J2534 pass-thru device that supports the latest vehicle protocols, and an ADAS calibration software upgrade card for static and dynamic ADAS calibration coverage for most U.S., Asian, and European ADAS-equipped vehicles. The package includes targets, patterns, and calibration components to calibrate all ADAS systems on equipped vehicles, including camera, radar, lidar, and night vision systems. Includes Lane Departure Warning calibration targets and patterns for Mercedes-Benz, Nissan, Infiniti, Hyundai, Kia, Toyota, Lexus, Mazda, Mitsubishi, Subaru, Volkswagen, Audi, and Alfa Romeo camera-equipped vehicles are included. Includes target case. The system enables calibration of radar-based front and rear-collision warning systems, around-view monitoring systems, lidar and night vision systems. The frame quickly disassembles for transport or space-saving storage. The frame ships with four tire clamps with camera targets, a steering wheel lock, brake chocks, a power supply, an alignment aid, and a frame cover. A one-year Limited Warranty covers the MaxiSYS IA700AST package.

AUTEL MAXISYS™

IA800

# INTELLIGENT ADAS

## OPTICAL POSITIONING SYSTEM

FASTEST, EASIEST & MOST PRECISE SETUP

NO MORE   
MECHANICAL  
MEASURES

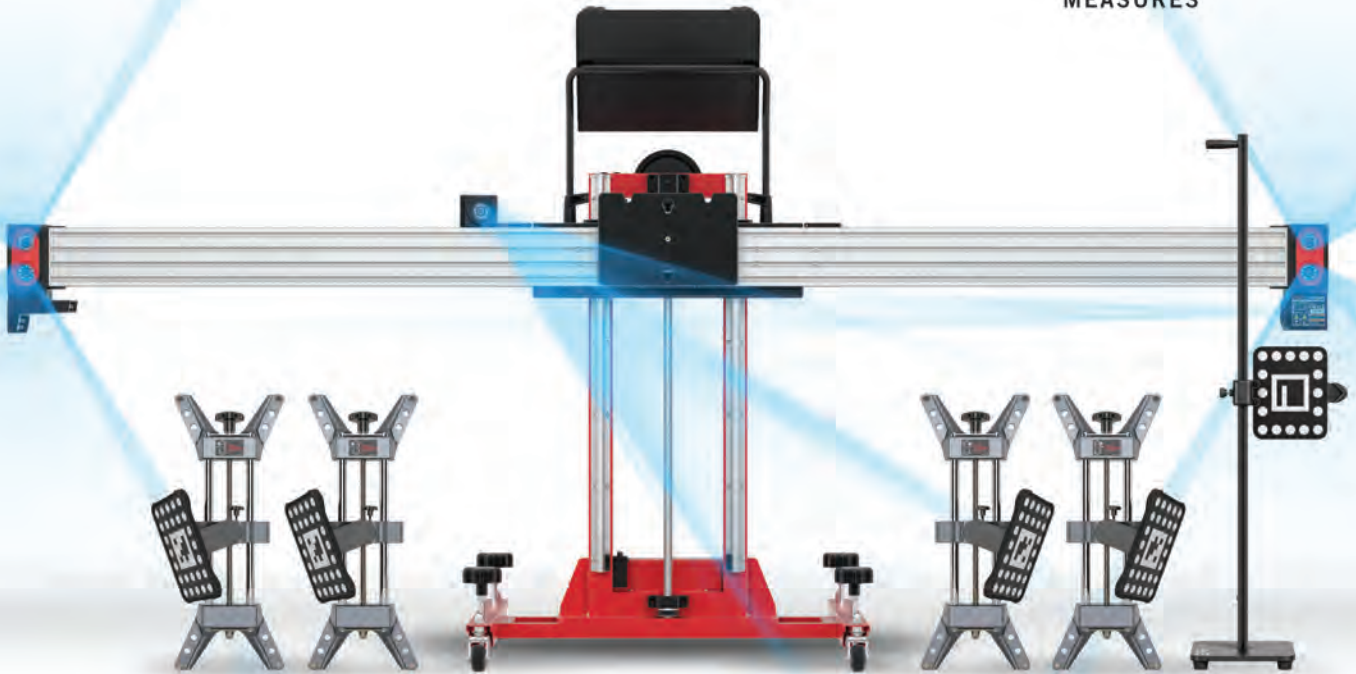

**AUTEL** IA800

EXPAND THE CAPABILITIES OF YOUR EXISTING

## STANDARD CALIBRATION FRAME





# CALIBRATE WITH CONFIDENCE

Know your team is using the most current vehicle data and technology ensuring all calibrations are completed accurately and returned to vehicle owners safely.

## IA800 EXPANSION PACKAGE ALSO INCLUDES:

### WHEEL CLAMP (4 PCS)

CSC0500-07-LF, CSC0500-07-LR  
CSC0500-07-RF, CSC0500-07-RR

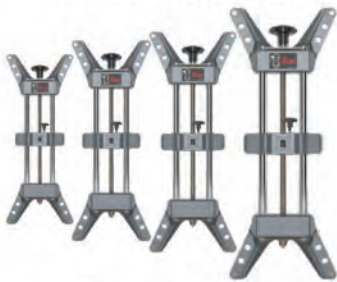

Attach To Wheels  
Secure Use With Targets

### DISTANCE TARGET

CSC0500-08



Frame Distance Measure During  
Frame Placement

### TARGET (2 PCS)

CSC0500-09-LF  
CSC0500-09-RF



Two Targets Use During  
ADAS Calibration

### TARGET (2 PCS)

CSC0500-09-LR  
CSC0500-09-RR



Four Targets Use  
During Alignment Check



### WHEEL CHOCK (2 PCS)

Secure Vehicle Wheels  
During Alignment Check



### TABLET SUPPORT

Hands Free Operation  
During Frame Placement



### STEERING WHEEL LOCK

Secure Steering Wheel  
During Alignment Check



### 24V POWER ADAPTER

Power To IA800 Cameras  
During Frame Placement

**IA900WA** PART NO: IA900WA

- IA900 WHEEL ALIGNMENT SYSTEM
- ACCESSORIES
- REQUIRES MAXISYS ULTRA, ADAS & WHEEL ALIGNMENT UPGRADE SOLD SEPARATELY

**IA900WA+TABLET** PART NO: IA900WAT

- IA900 WHEEL ALIGNMENT SYSTEM
- ACCESSORIES
- MAXISYS ULTRA ADAS TABLET & MAXIFLASH VCI
- ADAS & WHEEL ALIGNMENT SOFTWARE INCLUDED



**ACCESSORIES INCLUDED**

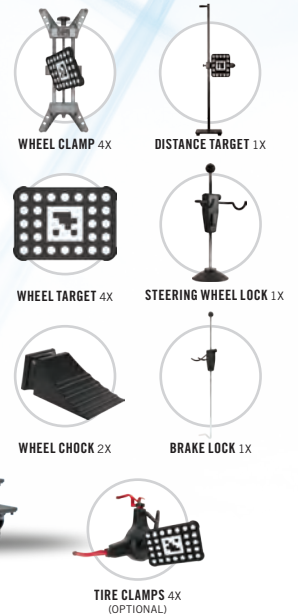

**IA900WA LDW PACKAGES**

EXPANDS LDW CALIBRATION CAPABILITIES

**IA900WA LDW** PART NO: IA900LDW

- IA900WA
- ACCESSORIES
- LDW TARGETS
- REQUIRES MAXISYS ULTRA, ADAS & WHEEL ALIGNMENT UPGRADE SOLD SEPARATELY

**IA900WA LDW+TABLET** PART NO: IA900LDWT

- IA900WA
- ACCESSORIES
- LDW TARGETS
- MAXISYS ULTRA ADAS TABLET & MAXIFLASH VCI
- ADAS & WHEEL ALIGNMENT SOFTWARE INCLUDED



**LANE DEPARTURE WARNING**

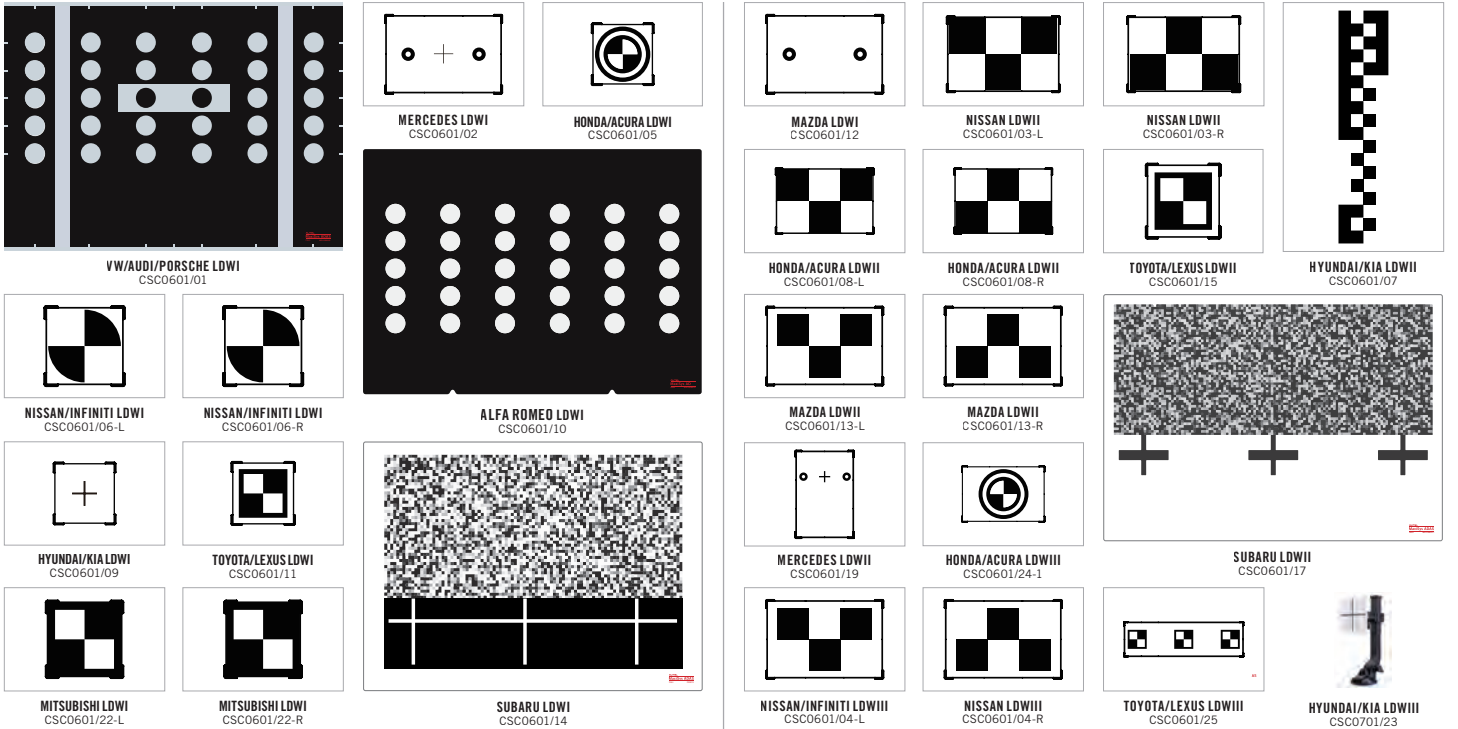

# ADAS CALIBRATION SYSTEM

## DAS 3000

Vision Positioning System automatically measures vehicle distances and angles—ensuring precise camera and radar calibrations

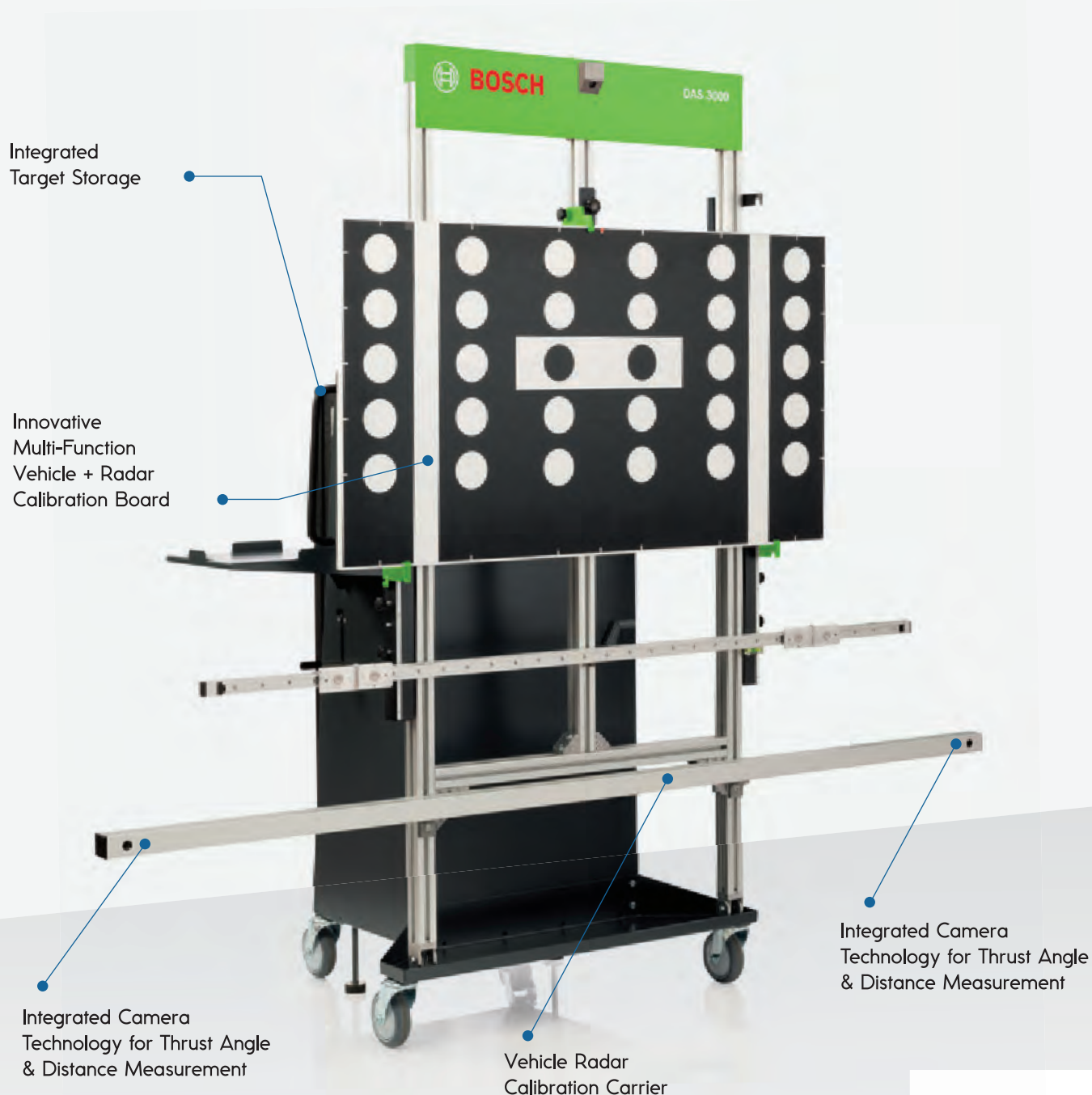

Integrated Target Storage

Innovative Multi-Function Vehicle + Radar Calibration Board

Integrated Camera Technology for Thrust Angle & Distance Measurement

Vehicle Radar Calibration Carrier

Integrated Camera Technology for Thrust Angle & Distance Measurement



**BOSCH**  
Invented for life

**4K  
MONITOR**

ROTARY  
MCS

## BASE ADAS CAMERA CALIBRATION KIT

### 75" HD MONITOR CREATES DIGITAL VEHICLE TARGETS

Single high resolution display shows a full range of integrated non-scaled targets

### Accurate laser positioning of machine to vehicle via Bluetooth technology

- Precise, fast millimeter adjustments of tilt and pivot screen movements
- Oversize 360 degree motion casters

### Fast, accurate and repeatable laser distant measuring

- Software confirms step-by-step guided frame adjustments reducing errors versus manual measuring

### Software versatility

- Choose how to use the machine with either OEM or MCS Windows based tablet



## MEET EVERY OEM SPECIFICATION WITH DIGITAL PANEL DISPLAYS



## SWITCH TARGETS WITH A PUSH OF A BUTTON!

**Save shop space and increase workflow speed!**

**Don't waste time storing and finding targets!**

- Target images are transmitted by software to onboard PC and positioned based on the connected vehicle
- Digital 1 to 1 image size of current OEM target
- Digital target inventory is always up-to-date

## Calibration targets and accessories

A complete offering for every kind of specific workshop service need\*



360° CAMERAS AND DOPPLER



IR CALIBRATION TARGET NIGHT VISION CAMERA



BLIND SPOT RADAR REFLECTOR

\*Contact a factory representative concerning product details for available expansion kits



# 4 SOLUTION LEVELS TO CHOOSE FROM



## LEVEL 1 Base ADAS Calibration

Customize the base package to suit your service needs.

Can be upgraded to include a Rotary tablet that also works with Rotary aligners.



BASE ADAS EQUIPMENT



## LEVEL 2 ADAS + Wheel Alignment

Bundle digital ADAS offerings with Rotary 3D camera aligners and flush mounted alignment lifts to maximize shop productivity and flexibility.

ADAS and aligner system can be seamlessly swapped out in front of a vehicle to help you complete services in any area of your shop, not just a single bay.



R1085 MOBILE ALIGNMENT SYSTEM



XA14 FLUSH MOUNTED ALIGNMENT SCISSOR LIFT

ROTARY PACKAGES	LEVEL 1									LEVEL 2	
	FRONT FACING CAMERA	FORWARD RADAR	RADAR TRIHEDRALS	BLIND SPOT MATS	LIDAR	360° VIEWS	NIGHT VISION	EXPANSION PACKS	ROTARY TABLET*	R1085 ALIGNER	XA14 LIFT**
GOOD	X	X	-	-	-	-	-	-	X	X	X
BETTER	X	X	X	X	X	X	-	-	X	X	X
BEST*	X	X	X	X	X	X	X	X	X	X	X

\*Can be added to any LEVEL 1 PACKAGE \*\*Bundling an Aligner or Alignment Lift (or both) comes with Rotary tablet

\*BEST PACKAGE contains ADAS coverage components, targets, and patterns for most statically calibrated vehicles



## LEVEL 3 Full Vehicle Diagnostics

Our partner TEXA offers full vehicle diagnostic capabilities with its IDC5 software, Axone Voice tablet and a multi-connection hub to calibrate, update and/or change sensors or programming on most vehicles. *Package upgrades are available.*



CALIBRATION DEVICES AND SOFTWARE

## LEVEL 4 Diagnostics Solutions

TEXA is now future ready with a lineup of other diagnostic solutions for headlights, tire pressure monitoring systems and exhaust gas analysis.





# DIAGNOSTIC TOOLS AND ACCESSORIES



**CALL US TODAY**

**FOR THE BEST  
EQUIPMENT & SERVICE!**

(855) 999.SCCE

## **MAXISYS MSULTRA EV**

**ADVANCED EV DIAGNOSTICS WITH  
MAXIFLASH VCM1**



## **MAXISYS MSULTRA**

**ADVANCED DIAGNOSTIC  
TABLET**



## **MAXISYS MS919**

**ADVANCED DIAGNOSTIC  
TABLET**



## **MAXISYS MS909EV**

**ADVANCED EV DIAGNOSTICS WITH  
MAXIFLASH VCI/J2534**



## **MAXISYS MS909**

**ADVANCED DIAGNOSTIC  
TABLET**



# MAXIIM IM608PROIIKPA

ADVANCED IMMO AND KEY PROGRAMMING BUNDLE



# MAXIBAS BT609

BATTERY TESTING AND ANALYSIS



# MAXICHARGER AC ELITE HOME 50A

EV CHARGER WITH IN-BODY HOLSTER





# WHEEL SERVICE



**CALL US TODAY**

**FOR THE BEST  
EQUIPMENT & SERVICE!**

(855) 999.SCCE

# R1090

## PRO 3D ALIGNMENT SYSTEM

### HIGH PERFORMANCE SYSTEM WITH SOLID VISION TECHNOLOGY

Equipped with fixed cameras, tire grabbing clamps and remote controlled sensors.

- Automatic positioning of the cameras
- Automatic recognition of the targets
- ADAS ready

### 3D CAMERAS COMMUNICATE VIA BLUETOOTH

No cables or interruptions during alignment process.

### AUTOMATIC LIFT LEVEL COMPENSATION

This innovative wireless system can be used on a number of service of lifts thanks to its automatic flatness compensation.

### AUTOMATIC CAMERA POSITIONING - ALIGNMENT READINGS IN SECONDS

No adapters required while obtaining caster readings

### NO MINIMUM BAY SIZE REQUIRED

Wireless capability with the mobility to move from bay to bay

### FAST AND EASY SET UP

with Console or Tablet Operated System

- Includes Android Tablet as a REMOTE indicator

Easy to follow alignment process with updated graphics that feature a time saving

### On Rack Test Drive Program

- Animated instructions
- Easy to read results
- Adjustment Illustrations
- Live adjustments
- Email or print alignment report

**Handheld tablet allows techs to read and make adjustments anywhere in the bay!**

### PRECISION TARGET READING HIGH RESOLUTION FIXED CAMERAS

New smaller, rubber armored, wireless measuring heads with digital display keyboard with remote-control function



### SINGLE SENSOR SUPPORT PROVIDES HEAD POSITION ON RUNWAYS FOR MULTIPLE VEHICLE WHEELBASES

Quick clamp to the lift, this pivoting support avoids damage with obstacles while lowering.



Requires a single head position to measure different wheel base vehicles.



Bluetooth transmission between measuring heads and control unit.

Large 32" HD Monitor



New portable cabinet with increased storage.

Compact size for workshops with limited space.



### QUICK RELEASE BATTERY CHARGE STATION

Convenient charge station on cabinet unit top. Swap batteries without losing readings. 8-hour battery life allows a full day of work.



### EXCLUSIVE 3DT® TARGETS with Solid Vision Technology EXTREMELY FAST NO ROLL-BACK COMPENSATION REQUIRED FOR MOST VEHICLES

- Extremely light
- No electronic components inside
- Built in leveling display
- No maintenance required



### 3 POINT + QUICK LOCKING TIRE CLAMPS

FAST SETUP with 4 self-centering 3 point tire clamps - includes quick locking units and ABS claws.





### HANDHELD TABLET CONNECTS VIA WIFI

Take the alignment tablet with you as you make assessments, adjustments and collect the necessary data to get the job done from anywhere in the bay.



### Always have live readings while making adjustments

The standard magnet kit is adhered to the back of the tablet allowing positioning directly to the lift or vehicle during the measuring processes.

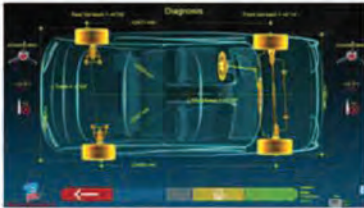

### UPDATED ANIMATED INSTRUCTIONS AND GRAPHICS GUIDE THE ALIGNMENT PROCESS

INCLUDES Spoiler Program for lowered vehicles - measures sport and tuned car bodies.

## R1090PRO ADVANTAGES

### TOWER FREE SYSTEM

Maximize available workspace.  
Don't give up valuable bayspace in your shop.

### NO MINIMUM BAY SIZE REQUIRED

No fixed obstacles or obstruction in front of lift.  
Portable aligner console can be positioned anywhere for the ultimate convenience.

### NO COMPENSATION or ROLL BACK\*

No physical rolling or pushing of the vehicle to make runout compensation. Automatic and instant 3D target visualization.  
\*FOR MOST VEHICLES

### NO INTERRUPTIONS

Perfect transmission signals. Always.

### NO LIMITATIONS Can be used at any height!

No need to dedicate bays for alignment service only.  
Use the aligner in more than one bay location with optional sensor supports.



SCAN CODE FOR PRODUCT VIDEO

### STANDARD EQUIPMENT

- 1 control unit with PC, 32" monitor, keyboard, printer, mouse and mouse pad
- TABLET for running the Connect APP
- Wi-Fi dongle
- Remote control located on each sensor
- 2 measuring heads
- Extra set of batteries (2)
- 4, STDA35E/3D 3-point clamps with targets
- Set of 6 extensions for dually wheels
- 1 brake pedal depressor
- 1 steering wheel lock
- Instruction manual
- Runs on WINDOWS 10
- Two years free vehicle data updates
- 3-Year Parts Warranty
- 1-Year Labor Warranty

### OPTIONAL EQUIPMENT

#### STDA3D/QC

Kit of two stands for model R1080.  
For use with the R1080 Sensors as a Quick Alignment Check.



#### #S130205 Turning Radius Gauge

Single 1.5" tall stainless steel radius gauge  
No Pointer / 1-1/2" tall  
4,500 lbs. (2,041kg) capacity  
(2 required)



#### #S130237 Turning Radius Gauge

Single 1.5" tall stainless steel radius gauge  
No Pointer / 1-11/16" tall  
4,500 lbs. (2,041kg) capacity  
(2 required)



#### #WS0036

**Cordless VIN Scan Tool**  
Includes charging/communication base, and 4-port USB adapter.

TECHNICAL DATA	ACCURACY	MEASURING RANGE	TOTAL RANGE
<b>FRONT AXLE</b>			
Total toe	+/- 2'	+/- 2'	+/- 20"
Partial toe	+/- 1'	+/- 1'	+/- 20"
Set-back	+/- 2'	+/- 2'	+/- 5'
Camber	+/- 2'	+/- 3'	+/- 10"
Caster	+/- 5'	+/- 10'	+/- 18"
King pin	+/- 5'	+/- 10'	+/- 18"
<b>REAR AXLE</b>			
Total toe	+/- 2'	+/- 2'	+/- 20"
Partial toe	+/- 1'	+/- 1'	+/- 20"
Set-back	+/- 2'	+/- 2'	+/- 5'
Camber	+/- 2'	+/- 3'	+/- 10"
Thrust angle	+/- 2'	+/- 2'	+/- 5'
Power supply	110v / 1Ø / 60 Hz		



# R1200 TIRE CHANGER

Rotary's new leverless dual bead breaker changer provides your shop with a tire-changing powerhouse, keeping the most difficult to change wheels safe from damage. This changer has chain synchronized bead breaker arm(s) with power-assisted positioning. The mount/demount tool, upper and lower rollers easily index together with the same single control.



## SPECIFICATIONS

- Adjustable height quick-locking center post
- Fully synchronized dual bead rollers & premium leverless tool
- Wheel lift
- Easy to use controls
- Power-assisted press arm
- Match mount indexing
- Blast inflation





# R180 PRO 3D AUTO TECHNOLOGY

## ELECTRONIC BALANCER with MICROPROCESSOR

### EQUIPPED WITH AUTO WHEEL DIMENSION SONOR and LASER RIM SCANNER

PERFECT BALANCING WITH MAXIMUM SPEED AND PRECISION

### AUTOMATIC BALANCING MODE

The R180 saves time and material cost.

Faster efficient balancing reduces wheel weight consumption while reducing spins and repositioning time lost. Interactive screen output identifies hidden weight location position, provides detailed analysis for precision weight placement.

### AUTOMATIC LOCK IN POSITION

Automatic start when the cover is lowered.

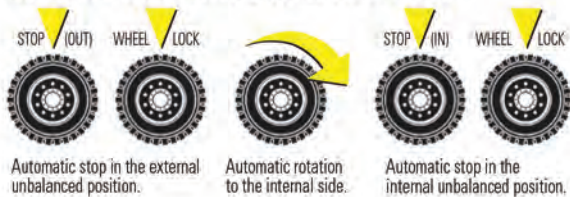

### AUTOMODE

After lowering the hood the sonar automatically detects wheel dimension.

- The laser scans rim profile
- Balancing program is auto selected
- Adhesive weights are positioned and memorized
- Wheel spoke quantities are checked and position for proper location of hidden weights is located
- Easily switch readout from ounces to grams

### PROGRAM FEATURES



#### MONITOR KEYBOARD

Linked directly to a standard monitor, this durable touch-pad allows for a "gloved" input with the convenience of a touch screen monitor.

### GUIDED BALANCING PROCEDURE

The functions related to each key vary according to use and are identified by icons on the display for easier understanding. Residual static readings are displayed throughout service functions.

#### SPOKE

Hidden weight program



#### SPLIT PROGRAM



#### ALU-S

3 automatic ALU S programs



QUICK LOCK



#### LASER WHEEL SCANNER

The laser pointer indicates the exact positioning for weights



SCAN CODE FOR PRODUCT VIDEO

### STANDARD ACCESSORIES

OPTIONAL ACCESSORIES SEE PAGE 5

HW150400132 / 2.07" - 4.35" (52.5-110.7mm)

Seven-piece Pro Collet Kit 40mm

- Clad Wheel Problem Solver
- Static Imbalance Solution
- Lower Taper = Better Mounting
- No Wheel Hub Interference



GAR 112  
Light truck cone  
3.75" - 5" (95-124 mm)



GAR 345  
Large quick nut  
replacement lock



Caliper and Pliers



Wheel diameter: 10" - 30"  
Tire width: 1.5" - 22"  
Maximum tire diameter: 44"

R180 PRO 3D AUTO services:



Optional equipment may be required

**DIMENSIONS:**  
HEIGHT: 57.125" / 66.5" with hood up  
WIDTH: 53.625"  
DEPTH: 30.375" / 35.625" with hood up

TECHNICAL DATA	R180
Max. assembly weight	176 lbs. (80kg)
Read out accuracy	1 g
Cycle time	6 seconds
Rotation speed (rpm)	<100
Power supply	110v / 60 Hz / 10



# FRAME REPAIR



**CALL US TODAY**

**FOR THE BEST  
EQUIPMENT & SERVICE!**

(855) 999.SCCE



# PHOENIX™ PULLING RACK

Designed and engineered with industry-leading features you've come to expect from CHIEF®, the NEW PHOENIX™ Frame Rack offers the size, capacity and flexibility for your shop to profitably repair the vehicles of today!



## PUT DAMAGE IN ITS PLACE AND PROFIT IN YOUR SHOP!

### FEATURES

- 12,000 lbs. Lifting Capacity
- Self-Leveling Deck
- 20' and 22' Rack Lengths
- Variable Height Technology with Six Working Heights from 19"- 40"
- Powder Coated Components

### FEATURING PORT-A-FRAME! CHIEF'S NEW INNOVATIVE HEAVY-DUTY LIFTING SYSTEM



- 12,000 lbs. lifting capacity with a 22' by 92" deck supports repairs from cars to large delivery vans
- Variable working heights for ergonomic vehicle access

### FAST & EFFICIENT TOWER CONNECTION!



- Multiple in-deck quick connectors plug in at 4 deck corners to adjust to different angles for multiple pulling
- Hoses with quick connectors store inside frame deck

### EXCLUSIVE! VARIABLE HEIGHT RACK WITH INTERNAL PUMP ALLOWS FOR MORE WORKSPACE



- Unique hydraulic pump lifting system is centered in middle of rack
- Electric-over-hydraulic provides for smoother, quieter operations

### EASY-TO-USE CONTROLS IN THE PALM OF YOUR HAND!



- All height and pull functions are controlled from a hand-held pendant control
- No hassles with foot pumps or changing out lines

## OPTIONAL RAMP LENGTHS FOR FAST, EASY LOADING!



- Removable for 360° tower access to free up needed bay space when lifted from the deck
- Redesigned hinged ramps are adjustable to compensate for uneven floors.
- Optional lengths allow for quick loading of low-profile sports cars to large trucks

## Tall towers with 10 tons of power at the hook

allows techs to easily perform multiple simultaneous pulls. Gang towers anywhere for 360° pulling around the deck perimeter for absolute control over the repair process.

**High-performance tapered tower roller bearings** raise off channel when tower is locked and bear no weight during pulls for years of maintenance-free operation. Four bearings per tower.



## Universal Anchoring System

Comes standard with a set of four stands. Adjust and secure most vehicles for precise, four-point positioning.

The Uni-Clamp can be retrofitted onto existing universal anchoring stands and is designed to work with all Chief specialty anchoring products.



## Chief's Trademark Telescoping Tower Heads:

- Features rugged 1/2" chains proof tested to 14 tons
- Adjustable tower collars allow positioning on towers for precise pulls

**Tower rams** with 10" stroke provide 10-tons of pulling power.

**Tower collars** are designed to drop down if a clamp comes off vehicle to keep technicians safe.



**Patented Sure-Lock® mechanism** pins and secures towers with one movement for added speed and safety. Locks are designed to relieve pressure off the bearings while doing pulls, increasing durability of the rack.

**Handle extensions** make locking and unlocking towers easy.

**Pressure gauges at each tower monitor and control different pressures during multiple pulling.**

Valves allow towers to operate separately or simultaneously and keep clutter to a minimum.



The PHOENIX™ is compatible with all CHIEF® structural holding tools for new and late model vehicles.

**Two re-positionable cross members** add up to 280 positions for anchoring vehicle downpulls.



The rack surface features 170 tie-down openings for anchoring stands or any other attachments needed for multiple pulling requirements.

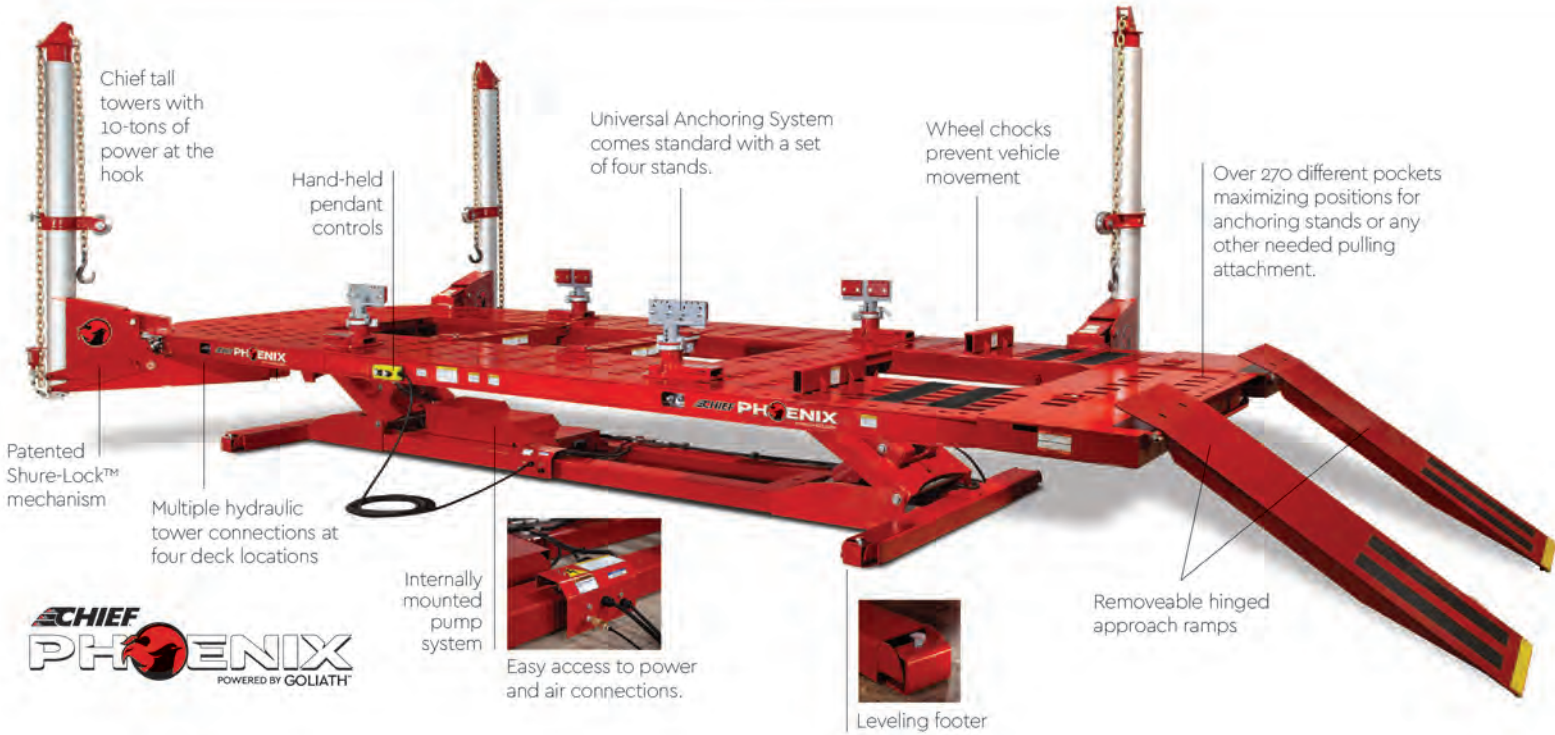

**SPECIFICATIONS / 22' RACK**

Maximum Length with ramps	28' - 6"
Maximum Width (Footprint)	7' - 8"
Maximum Height	9' - 4"
Height with tower rams extended	8' - 2"
Clearance required on all sides	2' - 2"
Tie-Down Openings - with optional cross-member	172 280
Tower Materials	5/16" and 3/8" High-Strength Steel
Deck Plate Strength	50,000 PSI Yield A-572 Steel Plating
Power / Single Phase	120 VAC / 20 Amp
Air Supply / Power Required	100 PSI
Weight: 2 Tower / 3 Tower	7,100 lbs. / 7,750 lbs.

**Optional Accessories** Contact factory for additional details and options

**Chief Tool Board Packages feature the most innovative tools for repair.**

Pulling accessories are available in various configurations, offering maximum versatility to keep pace with evolving automotive design. Make precise pulls on hundreds of unitized and conventional frame models while minimizing structural distortion.



**Deluxe Chain & Clamping Accessory Package**

When you need to do the job right. Wall Mount or Cart Mount option



Visit [www.chieftechology.com](http://www.chieftechology.com) for additional information and a parts breakdown.



Chief Collision Technology® reserves the right to alter product specifications and/or package components without notice.

# SMART RHONE

IS A MULTIPURPOSE BENCH DESIGNED TO HANDLE ALL KINDS OF LIGHT, MEDIUM AND HEAVY COLLISION REPAIR.

REF NO: RH19S.3501.x | RH19S.3502.x | RH19S.3503.x

The unique feature of SMART RHONE is QUICK ANCHORING. The vehicle can be anchored and ready to perform pulling operations in less than 15 MINUTES.

Compatible with NAJA 3D and EAGLE 3D electronic measuring systems.

SMART RHONE is the first of its kind which can also accommodate dedicated jigs (MZ+ system) and is compatible with CAMELEON, the universal adaptive jig system.

SMART RHONE is the extremely flexible repair solution for the technician, enhancing body shop productivity.

With a 3500 KG LIFTING CAPACITY along with 1300 MM LIFTING HEIGHT the SMART RHONE is versatile and supports all kind of vehicles in its segment.



QUICK ANCHORING OF VEHICLE AND READY TO PULL

SUITABLE FOR LIGHT, MEDIUM AND HEAVY COLLISION REPAIR

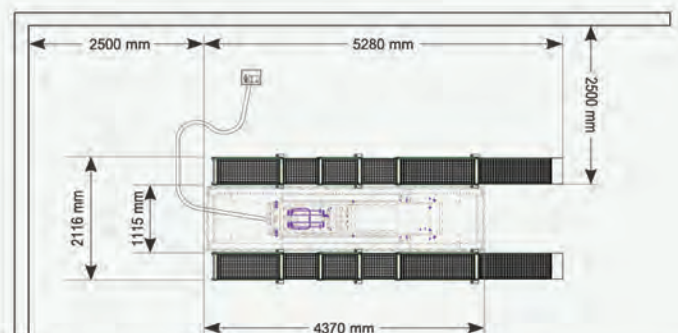
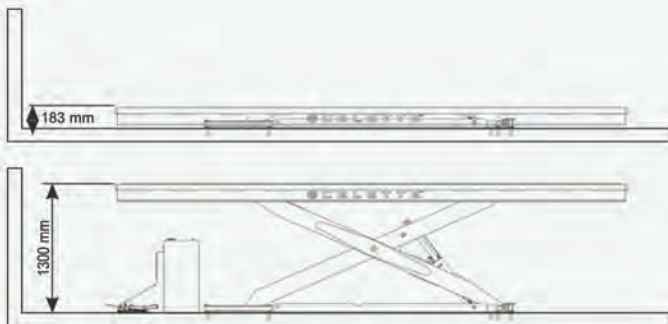

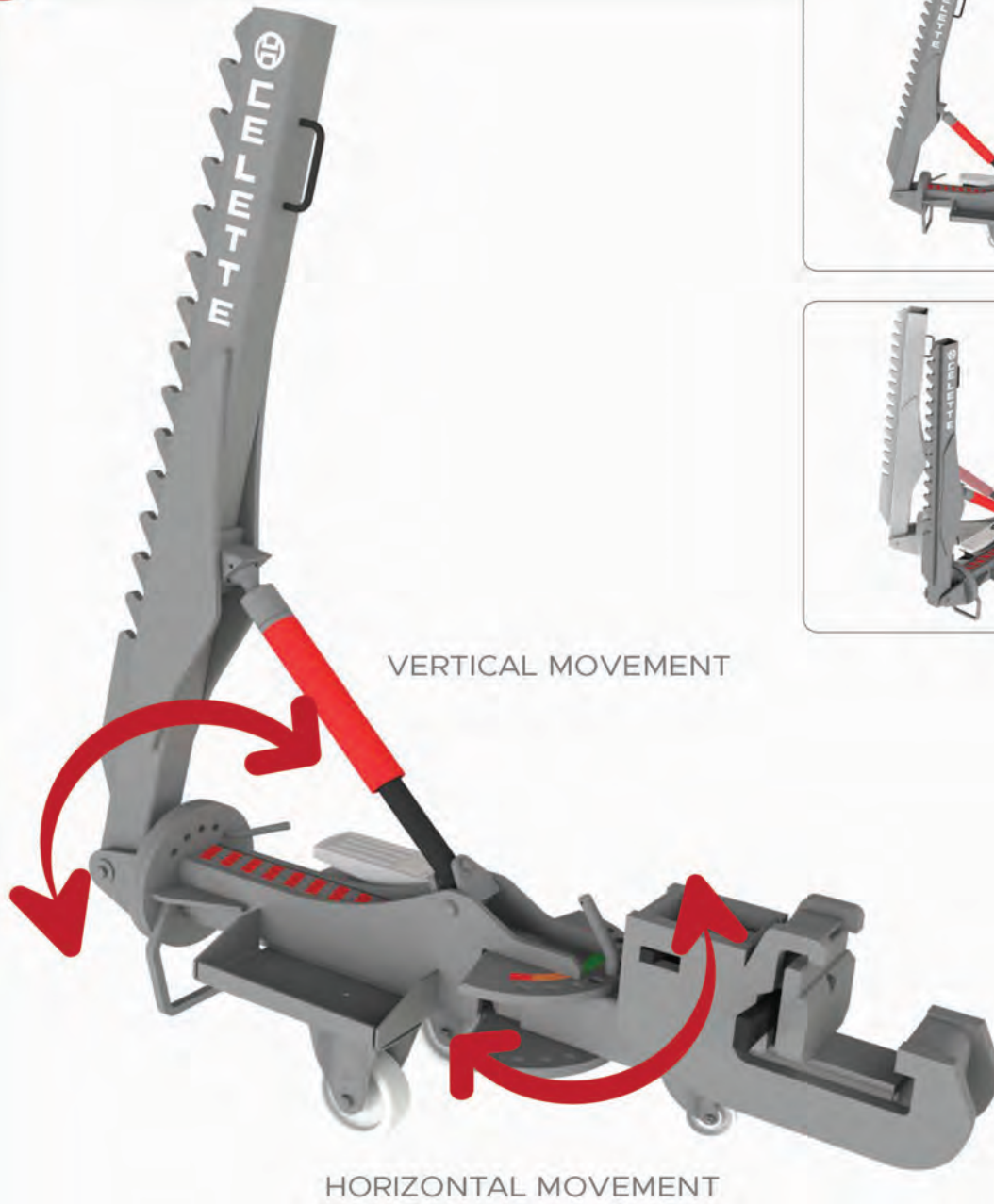

VERSATILE PULLING UNIT FOR OPTIMAL PULLING ANGLE EASY & QUICK MOUNTING TO THE BENCH WEDGE MECHANISM – NO FASTENERS

# RHONE 2.8T | 4.2T

DRIVE-ON BENCH WITH SCISSOR LIFT

REF NO: RH18M.4220.x

Rhone drive-on bench has been upgraded with a lifting capacity of 4200 kg and to a height of 1.32 m. The most versatile bench facilitates quick diagnosis and straightening with MZ / MZ+ and Cameleon universal bracket sets, pre and post repair reports can be obtained with Celette measuring systems. Thanks to the Celette vehicle loading trolley which enable you to load the damaged vehicles.

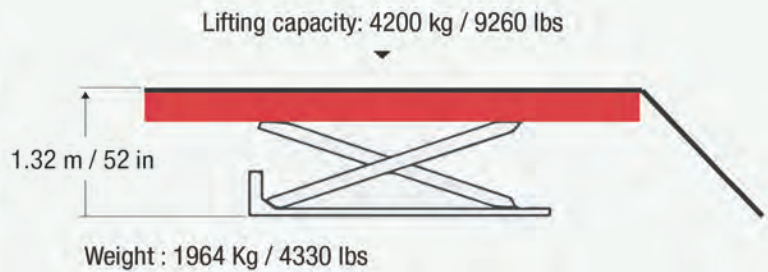
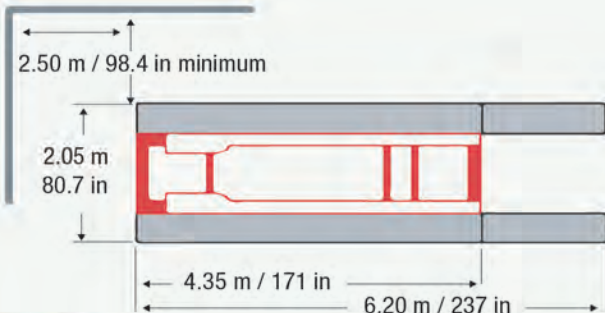
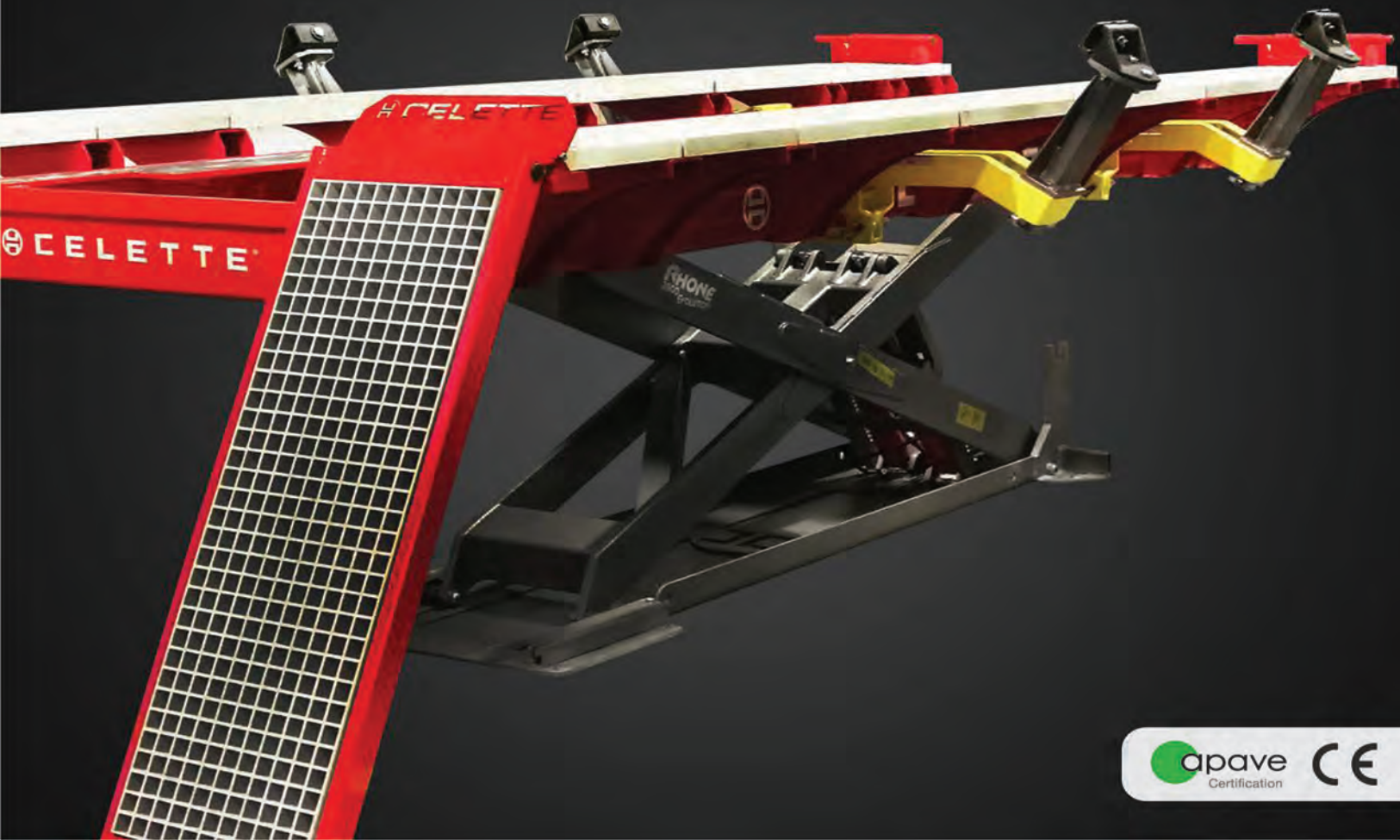



# RHONE L 4.2T

5-METER-LONG DRIVE-ON BENCH WITH SCISSOR LIFT FACILITATES QUICK LOADING

REF NO: RH18LM.4220.x

Rhone L is the longer version of Rhone drive-on bench with 5 m long and enhanced lifting capacity of 4200 kg. Maximum lifting height is 1.36 m. Recommended for long wheel base vehicle. The detachable rams provides better access to the vehicle while pulling and measuring.

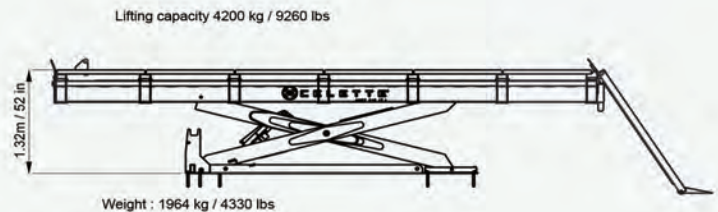
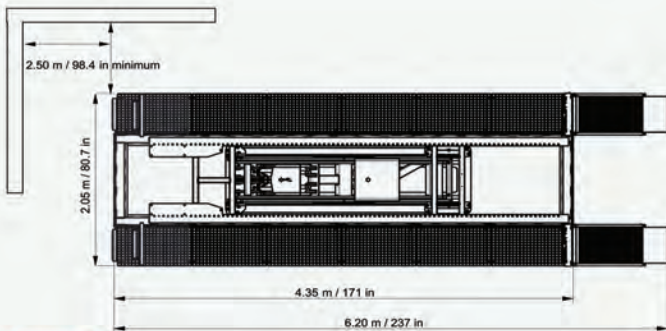

# SEVENNE

COMPLETE MOBILE BENCH ON WHEELS

REF NO: SVN17.3212

Sevenne is a universal mobile bench, which can be upgraded to Rhone or Griffon. The anchoring can be achieved all around the bench, thanks to its peripheral frame for quick fixing of wheels, clamps, multi-function supports, and a steering handle.

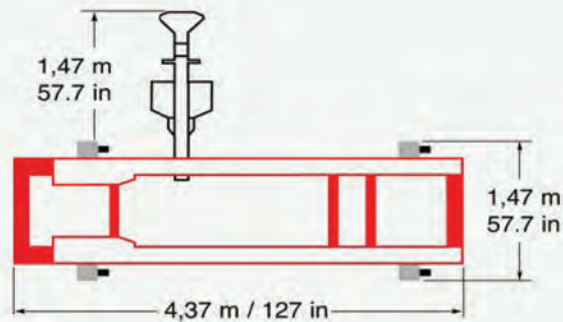

Weight : 750 Kg / 1653 lb

# SEVENNE XL

EXTRA LONG MOBILE BENCH ON WHEELS

REF NO: SVN09XL.3112

Extended length bench on wheels is specially designed for repairing larger commercial vehicles. The key feature of this bench allows to position under a 2-post lift for loading and to easily move between work bays. The 5.8 m (19 ft) length is suitable for light trucks and commercial vehicles. The universal peripheral frame enables quick anchoring, adjustment of the clamps, wheels, transport handle and multi-function supports.

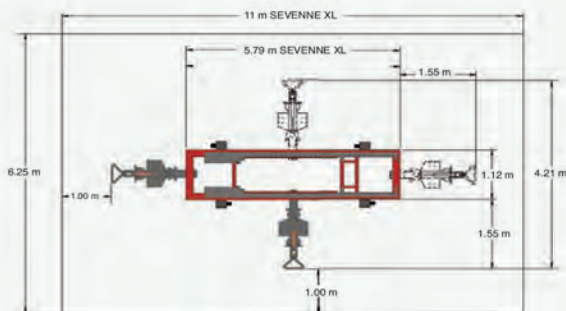

Weight : 1350 Kg / 2976 lb

# GRIFFON

DRIVE-ON BENCH WITH SECONDARY LIFTING SYSTEM

REF NO: GR16F.38021.x

Griffon is a drive-on bench with a 2800 kg lifting system using a runway decking plate. Dismantling the anchoring clamps and cross-members is not required while positioning the vehicle. The inner lifting system is operated by means of a remote control device.

Only a part of the runway decking plate (light but solid, made of composites) needs to be removed if the repairing process requires it. Extra heavy duty pulling unit with 10 Ton capacity.

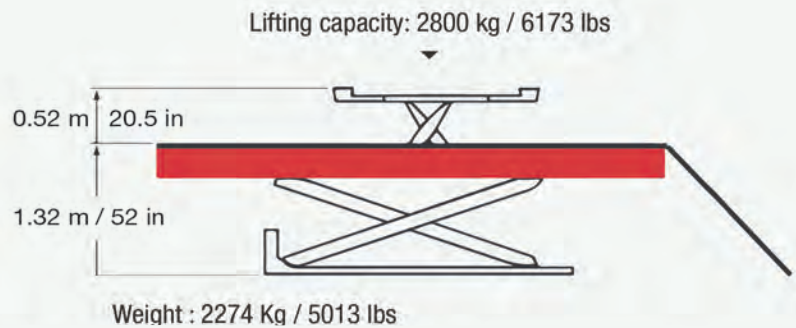
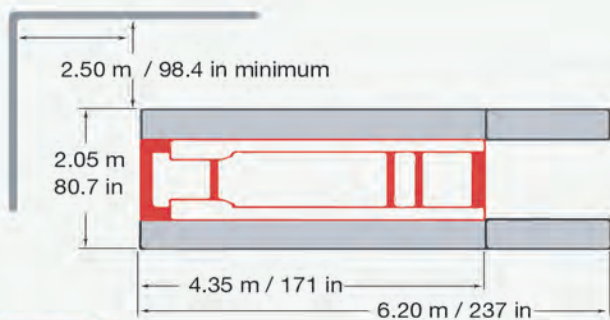
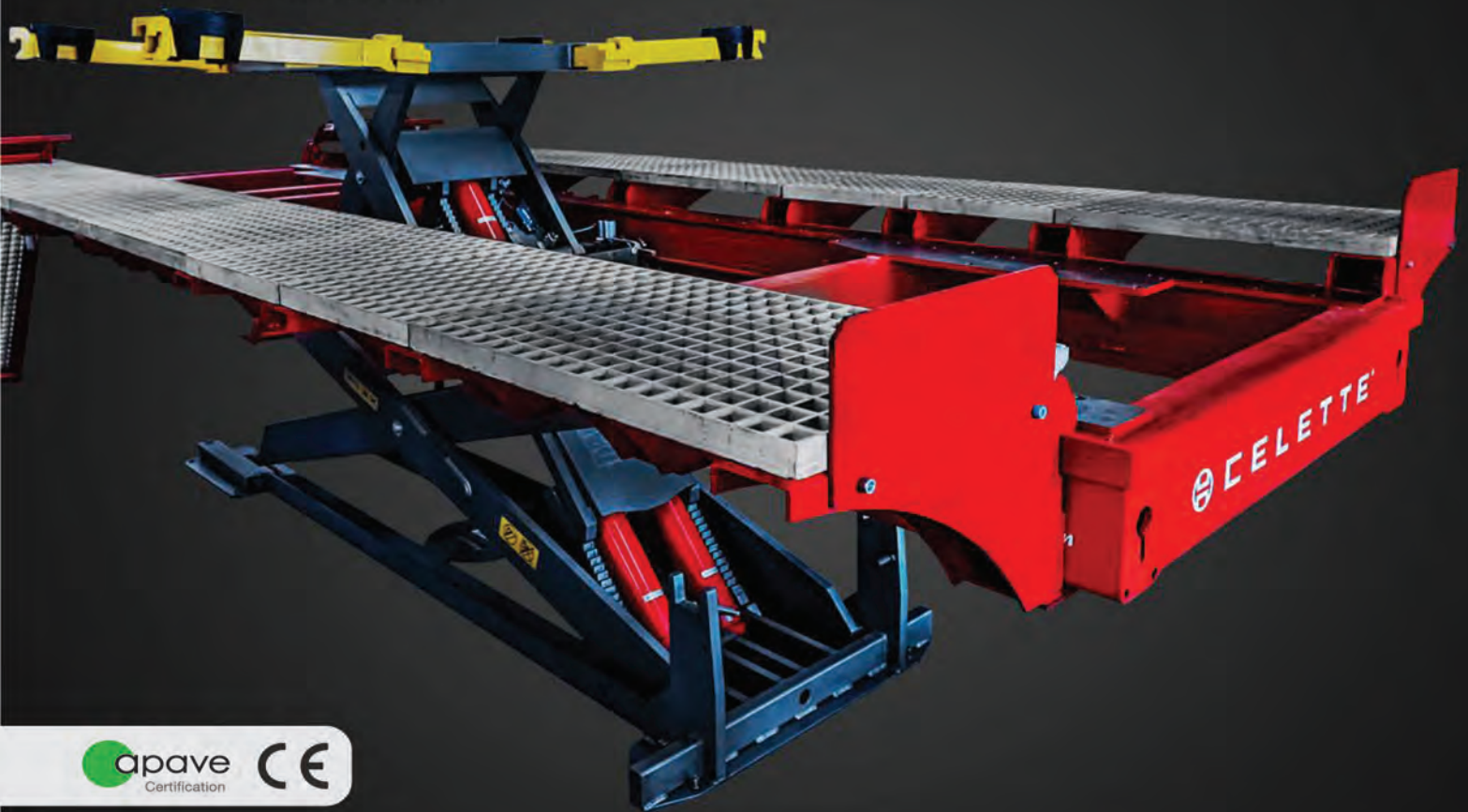

# GRIFFON VB

MOBILE DRIVE-ON BENCH WITH INTEGRATED INNER LIFTING SYSTEM

REF NO: GR05F.2022.x

Griffon VB is a mobile system with an added convenience of drive-on bench that enables you to organize any work bay into a straightening area. The bench remains mobile with the vehicle in position, thanks to the castor wheels. This bench is equipped with an inner lifting unit which can be operated by means of a remote control system.

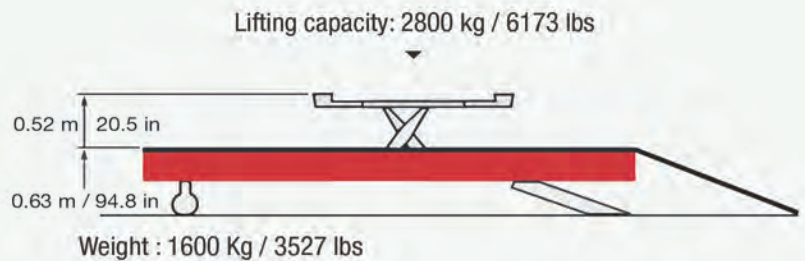
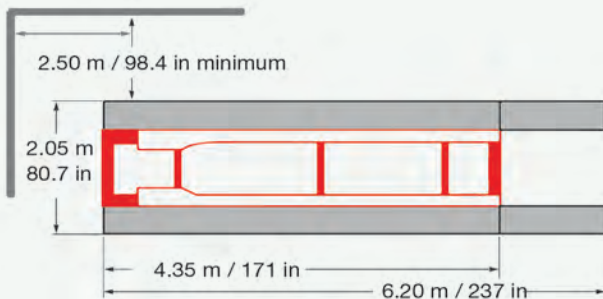

# GRIFFON XL

EXTRA LONG BENCH WITH TWIN LIFTING SYSTEM

REF NO: GXL08.5812.x

5.8 m long bench GRIFFON XL is specially designed for repairing commercial vehicles and SUVs. This length enables you to complete simultaneous repairs at both the front and rear of the vehicle. This bench is supplied with 2 independent inner lifting units and a hydraulic tilting system.

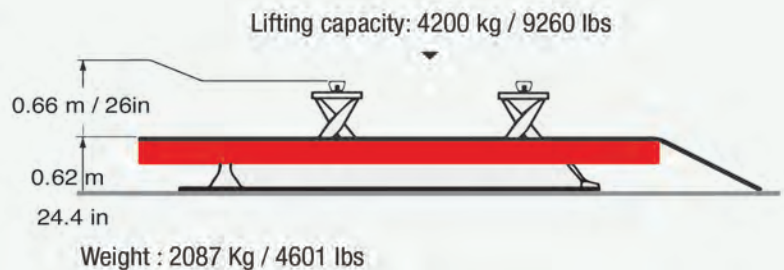
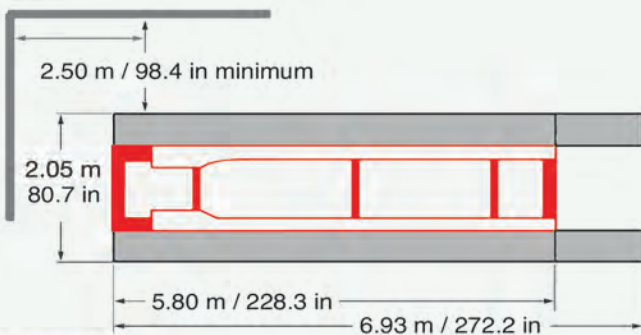

# X-TRAC

LIFTING AND PULLING PLATFORM - RECOMMENDED FOR LIGHT AND MEDIUM REPAIR

REF NO: XT14.3000.x | XT14.3500.x | XT14.3600.x

The ALL NEW X-TRAC with 4000 kg lifting and 10 Ton pulling capacity

X-TRAC is a lifting platform specially designed for light and medium repairs. Once the vehicle is positioned on the platform, it can be easily and rapidly lifted up by the wheels in order to enable the technician to get access to the anchoring points. X-TRAC has a secondary function, which can be used as a scissor lift for Sevenne Bench.

SMART | QUICK | EASY



QUICK BENCH

**4 TON**

LIFTING CAPACITY

360°

TOP VIEW

Regular

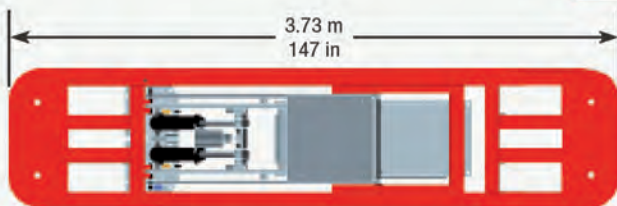

9200.20

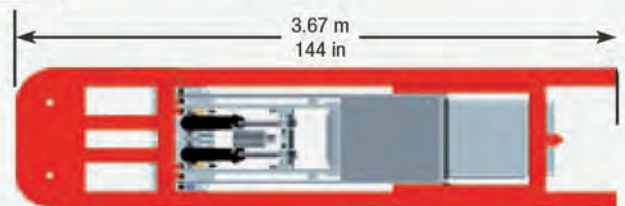

9200.01

# GLOBALJIG®

## MOBILE SYSTEM

Considered the top of its category, the Mobile System is equipped with the Globaljig Universal Fixturing System to allow the centering of a vehicle once fixed to the jigs, thus saving up to 75% of the time required to load a vehicle.

### Parts/Accessories:

- 36 mm. Combo hexagonal wrench (to secure the VECTOR to the Bench)
- Horizontal body with tool-holding pocket
- Vertical vody complete with snub pulley chain
- Upper connection and lower fork connection for application of the hydraulic cylinder

### SPECIFICATIONS

- Length: 2.15 m
- Width: 1.0 m
- Height: 330 daN
- Pulling force: 5/10 t
- Hydraulic cylinder stroke: 200 mm
- Max. operating pressure: 600 bar





# GLOBALJIG®

## EVOLUTION SYSTEM

Precisely engineered and built for attention to detail, the Evolution System—also known as the Evolution-Jig—is the ultimate bench solution for providing increased access and workability over mobile systems when using pinch-weld clamps and electronic measuring—or the Globaljig universal jig system. In addition, loading vehicles becomes a faster and easier process thanks to the tilt, designed to reduce winch strain and maintain the minimum height for safety.

### Parts/Accessories:

- Tilts
- Pulling tower on-board bocking system
- Internationally-patented monocube jig system
- Four cross beams
- A full set of jigs

### SPECIFICATIONS

- Length: 14.8 ft (4.5 m)



# GLOBALJIG®

## KOALA – PULLING RACK

The Koala Pulling Rack is a small straightening bench with great versatility and potential. Suitable for all situations, Koala can handle most of the structural work your shop will see. Compact and out of the way when not in use due to the 6" height when fully lowered. Economical enough to put in every technician's stall, as multiple benches can share removable pulling posts and other common tools.

### DESCRIPTION

- Sill Slamps with extension plates allows increased space between the bench and the vehicle, allowing room for any type of measuring system on the market.
- The mounting of the pull post is quick and simple, and it can be mounted anywhere 360 degrees around the Koala frame.
- Raise 5,500 lbs to a working height of 5 feet 3 inches. Koala lets you choose the most ergonomic working height, from just a few inches to almost five and a half feet.

### SPECIFICATIONS

- Length: 10ft
- Width: 3ft
- Min. Height: 6"
- Max. Height: 5' 3"
- Lifting Capacity: 5,500 lbs
- Weight: 3,241 lbs
- Working Footprint: 222" x 139"
- Power Supply: 220-240 V, 60Hz  
20 amps
- Single Phase Dedicated Line

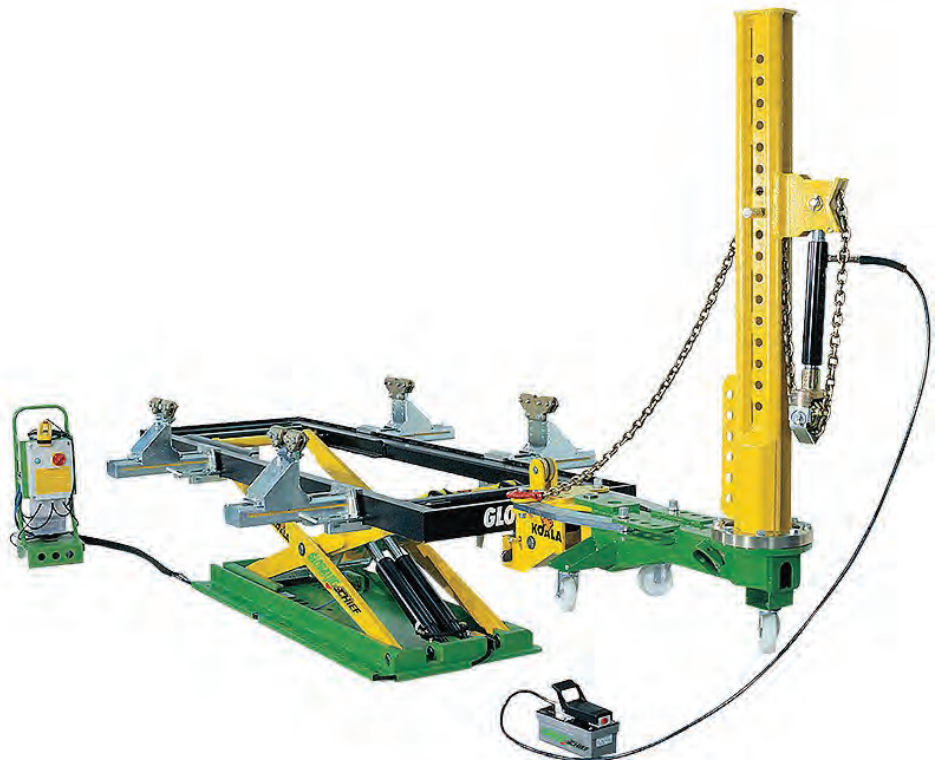

# GLOBALJIG®

## GLOBAL JIG X-PULL

The new X-PULL is a lift bench; it is very compact and allows great performance for many quick repair operations. The positioning of the vehicle is fast and practical; you lift the car on the rubber pads of the adjustable arms, and without the aid of wheel runner for alignment, you can mount the adjustable sill clamps to raise the vehicle from the support on the rubber pads. X-PULL is particularly suitable for “fast repair” today, so current and necessary.

### DESCRIPTION

- With the wide and fast height adjustment of the sill clamps, it is possible to fix and lock any type of vehicle that has the edges of the crests from a minimum 89 mm to a maximum of 308 mm.
- It is, therefore, possible to apply and use any type of system computerized electronic measurement on the bench.
- The adjustable brackets are always mounted on the frame, on which you manually use the sliding rubber pads adjustable in height, even when you are positioning the car, and those stackable are used to lift vehicles with higher bodies.

### SPECIFICATIONS

- Length frame: 118.11"
- Width frame: 34.17"
- Max height on frame: .049"
- Minimum height: 3.93"
- Lifting capacity: 6,614 lbs
- Rated Voltage: 380V
- Rated frequency: 50 Hz



# GLOBALJIG®

## SUPER ROTAX

Super Rotax offers effortless loading with removable ramps for unlimited access to the vehicle, a 360° view, and 10-ton pulling. Compatible with electronic measuring, the bench provides 5'9" of uninhibited working height with 11,000 lbs. of lifting capacity. Additionally, the tilts allow for efficient vehicle loading within minutes for 8-point holding or full fixturing.

### DESCRIPTION

- 360° 10-ton pull/push towers
- 5.75 feet of working height
- High-performance scissor lift structure
- Locking crossbeams
- Optional full-frame holding clamps are available

### Power Supply:

- 220-240 V, 60Hz 20 amps
- Single Phase Dedicated Line

### Weight:

- 8,298lbs.
- 9,416lbs.

### Working Footprint:

- 305" x 140"
- 345" x 140"
- Width: 78.7"
- Lift Capacity: 11,000 lbs.
- Max. Height: 69"
- Min. Height: 20.5" – Tilt Loading





# FRAME RACK ACCESSORIES/ TOOLBOARDS



**CALL US TODAY**

**FOR THE BEST  
EQUIPMENT & SERVICE!**

(855) 999.SCCE

# F.A.S.T. to Universal adapters



This adapter allows the use of F.A.S.T. accessories with Universal base plates

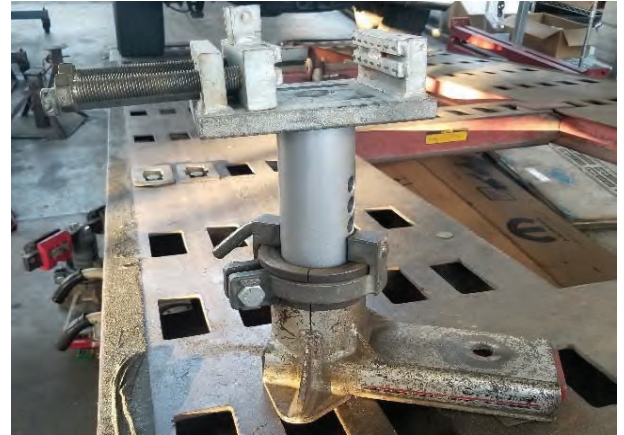

Standard adapter kit on left.

<

Standard deluxe kit on right. >



Use of these adapters along with the F.A.S.T accessories and Universal base stands allow a technician to quickly set up a vehicle for measuring. The rail saddle plates are also useful when used for measuring and they are wide enough to be used on the wider frames on some vehicles.

**“Not recommended for use in pulling procedures”**

Special thanks to the team at Selman Collision Center in Orange California and Chris Stoffel at Southern California Collision Equipment for their input in the development of these products.

Designed and distributed by AH&SI. Home of Ajon Mobility and A Rack Adaptors.

Prototypes shown in illustrations, finished product has 6 locator positions for finer height adjustments.



Chief Tool Board Packages feature the most innovative tools for repair of today's vehicles. These pulling accessories are available in various configurations, offering maximum versatility to keep pace with the evolution of automotive design.

# Structural Holding Package 300001

Part #128 - 300001 Weight: 555 lbs. (252 kg)

The Structural Holding Package is designed to give additional holding to newer vehicles manufactured with large amounts of High Strength and Ultra High Strength steels and additional Aluminum structures.

Structural holding allows a technician to apply additional holds, spreading out the amount of pressure at each hold location reducing the chance of additional damage during repairs. This holding is necessary to hold a part being replaced in the correct location for welding and bonding.

This system will fit any Chief or Chief style machines with rectangle holes on top of the deck. This concept allows a shop that has an older machine to be equipped with the latest technology in holding systems that will assist in repairs on the newest vehicles.

This Structural Holding Package is conveniently mounted on a tool board that outlines each component making it simple to identify where the part goes; all of this affixed to an easy-to-roll cart designed for the technician's convenience and a clean looking shop.

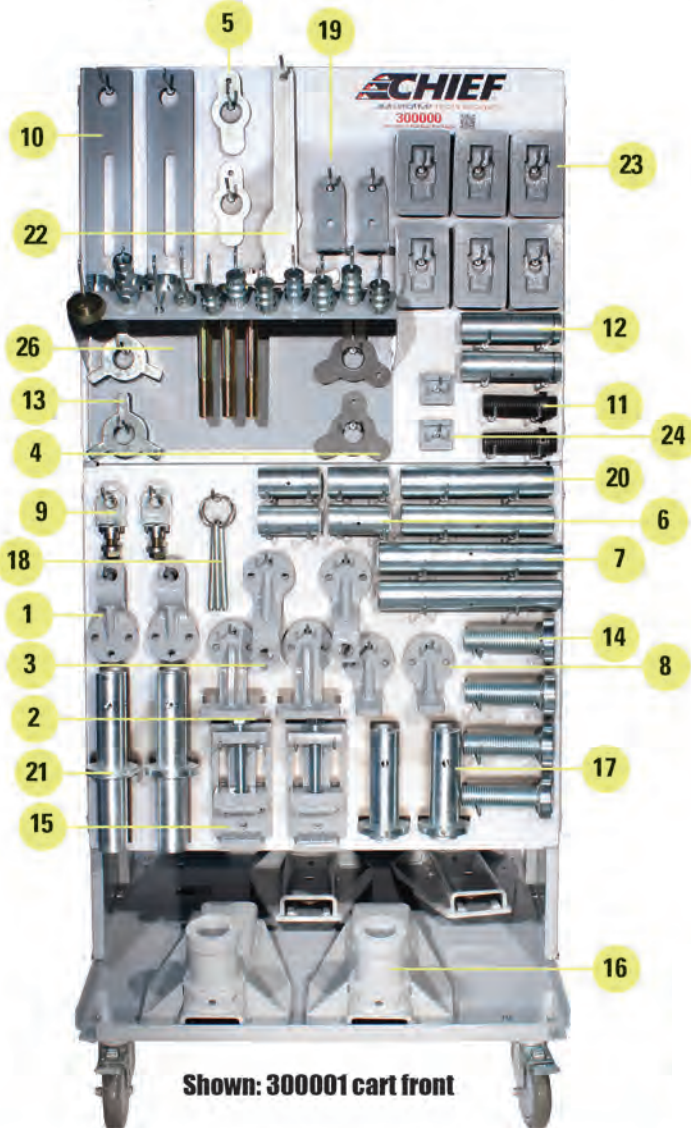
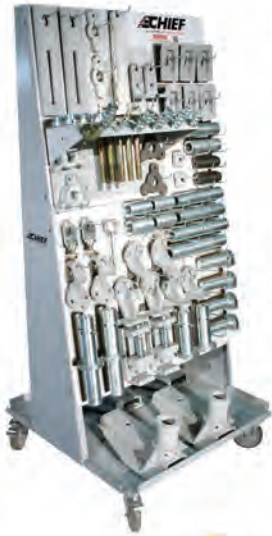

Shown: 300001 cart front

No.	Part No.	Qty.	Description
1	502000	2	Vertical Fixture Short
2	502005	2	Horizontal Fixture Large
3	502008	2	Vertical Fixture Tall
4	502014	2	Wing Nut, Parts Holding - LH
5	502015	4	Wing Nut, Parts Holding - RH
6	502016	4	4" Extension Tub
7	502017	2	12" Extension Tub
8	502019	2	Tall Horizontal Fixture
9	502026	2	Angle Adaptor Clamp Ass'y
10	502031	2	Base Plate
11	502033	2	Adapter, Parts Holding Lower
12	502034	2	Center Tub Parts Holding Turn Buckle
13	502038	2	Rigging Nut
14	502039	4	Structural Holding Adapter Ass'y
15	502042	2	Structural Vise Ass'y
16	502047	4	Structural Parts Holding Base
17	502055	2	Short Tub Base Stand Ass'y
18	502058	4	Release Pin Ass'y
19	502060	2	Wrist Block
20	502061	2	10" Extension Tub
21	502063	2	Tall Tube Base Stand Ass'y
22	502067	1	Spanner Wrench Ass'y
22	502069	1	Spanner Wrench Ass'y
23	607371	6	Fastener Plate, UAS
24	638133	2	Jaw Clamp Ass'y
25	611311Y	2	Parts Holding Arm (on cart back)
26	502062	1	Bolt Tray, Structural Holding



Chief Tool Board Packages feature the most innovative tools for repair of today's vehicles. These pulling accessories are available in various configurations, offering maximum versatility to keep pace with the evolution of automotive design.

# Structural Holding Package 300001

Part #128 - 300001 Weight: 555 lbs. (252 kg)



Shown: 300001 cart back

**The parts holding arm** allows for quick and easy set-up giving the technician the ability to adjust in all directions from any hole on the deck.

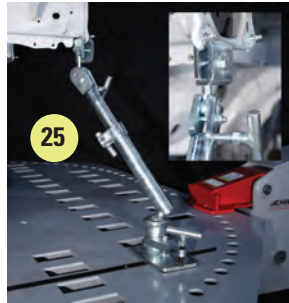

Part #611311Y / Parts Holding Arm

**Vertical fixtures** can mount to locations such as the suspension mounting areas creating a very strong hold for structural repairs.

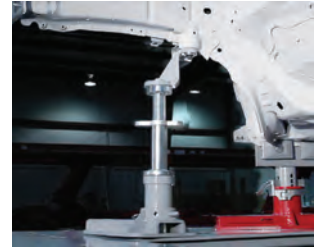

**The large horizontal fixture** allows the ability to hold and control the end of a rail or structure for alignment or replacement of that component.



**The structural holding package** can be used to make **eight point holding** where needed with suspension in or out.



The system can be used for **Unitized and Full Frame vehicles** utilizing the vise clamp to hold full frame rails.

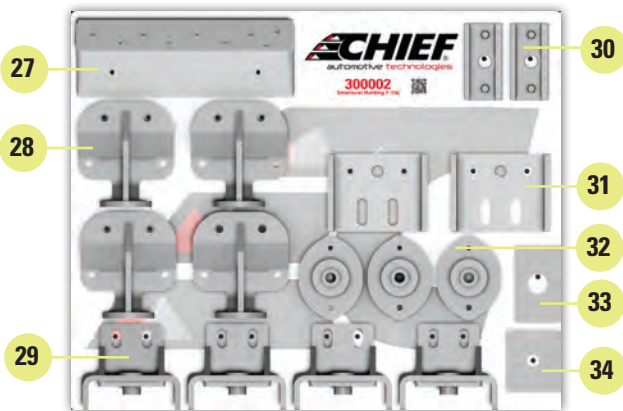
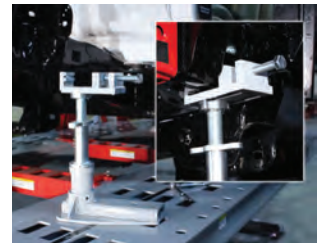

The **F150 Tool Board** allows three ways to create holds for repairs:

The **Rigid Cab Mounts** are used to replace the rubber factory cab mounts during structural repairs.

Additional holds can be made when using the **90° Angle Pinch-Weld Jaws** that mount to the rocker flange inconjunction with the FAST Anchoring system.

A third method of holding is using the **Running Board Fixture** in conjunction with the base and fixture extensions within this parts package.

**For additional kits for these brands and more, contact us!**



No.	Part No.	Qty.	Description
27	502070	1	Bolt Tray, Structural Holding, F150
28	640114	4	F150 Running Board Bracket Ass'y
29	640004	4	Weldment, Pinch-weld Base, F150
30	498110	4	Pinch Jaw with Nails Complete
31	640076	4	Formed Vertical Clamp, F150
32	640120	6	Weldment, Cab Mount, F150
33	640100	6	Support Plate, Cab Mount, F150
34	682953	4	Plate, EZ-Liner Tie Bolt





Chief Tool Board Packages feature the most innovative tools for repair of today's vehicles. These pulling accessories are available in various configurations, offering maximum versatility to keep pace with the evolution of automotive design.

# Structural Holding Package 300021

Part #300021 Weight: 555 lbs. (252 kg)

## Structural Parts Holding Base

*Equip and update your shop with the latest technology in holding systems and repair the newest vehicles on the market!*

*This holding system is designed to fit many non-Chief style machines without standard rectangle holes on top of the deck.*

The Structural Holding Package is designed to give additional holding to newer vehicles manufactured with large amounts of High Strength and Ultra High Strength steels and additional Aluminum structures.

Apply additional holds, spread out the amount of pressure at each hold location and reduce the chance of additional damage during repairs.

Chief's USH Clamp System can be used on a wide variety of Deck systems. Operators must have the correct size mounts.

### Anchoring with sliding base

#### IMPORTANT:

Usage of this system is dependent upon mainframe design and tread width.

Position clamp mount on top of machine's treadway at corners of vehicle's section.

Clamp mount must engage inner edge of treadway and outer clamp must engage outer edge of treadway.

Slide USH Sliding Base into clamp mount and position at desired location. Slide Structural Holding System tube into stand and build to desired height.

After locating the replacement part to the vehicle, secure clamp mounts to the treadway and sliding base within clamp mounts. The clamp mount bolts must be tightened to 80 foot pounds torque (maximum). The clamp mount hex socket set screws must be tightened - snug only.

**NOTE:** Always inspect clamping locations for fuel lines, brake lines, or other items which may interfere with attachments on vehicle.

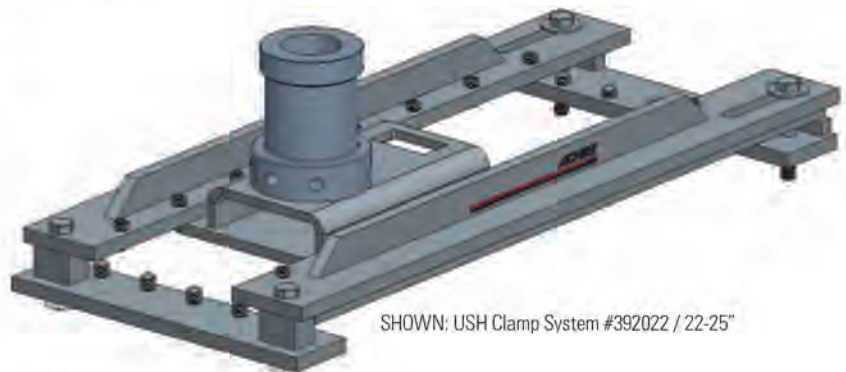

SHOWN: USH Clamp System #392022 / 22-25"

#### MODELS / AVAILABLE LENGTHS\*

#392020 / 16-19" USH Clamp System	#392023 / 25-28" USH Clamp System
#392021 / 19-22" USH Clamp System	#392024 / 28-31" USH Clamp System
#392022 / 22-25" USH Clamp System	#392025 / 31-34" USH Clamp System

\*Tool kit 300021 is to be used with one of the model numbers listed above - kit does not include the four bases which are sold separately

### Anchoring with thru holes in deck

**NOTE:** Long hardware bolts, tie down plate, and fastening bar will only be required when using with thru holes in deck, not with clamping systems.

Place USH Sliding Base Assm on flat level surface.

Using Hardware provided, use correct bolt length for the desired deck height. Use flat Washer when needed.

Using hole in deck, place Bolt through Tie plate and bottom of deck. Thread bolt into Fastening Bar.

Make adjustments as needed to locate Sliding Base to desired location.

Secure bolt.

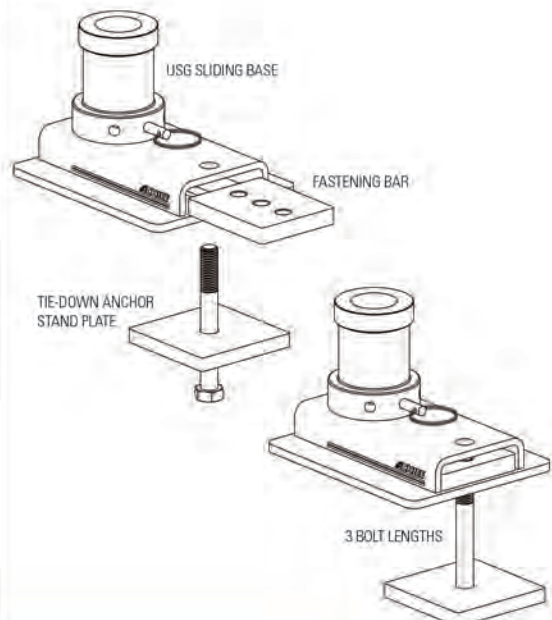
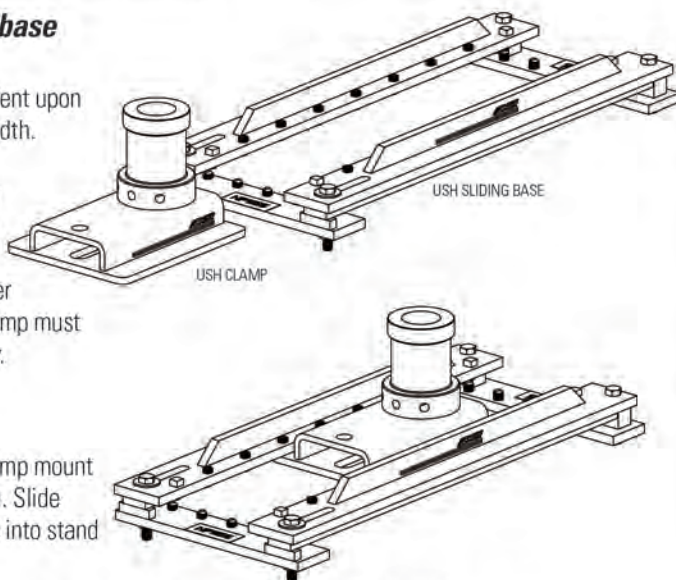

# Structural Holding Package 300021

Part #300021 Weight: 555 lbs. (252 kg)



This Structural Holding Package is conveniently mounted on a tool board that outlines each component making it simple to identify where the part goes; all of this affixed to an easy-to-roll cart designed for the technician's convenience and a clean looking shop.

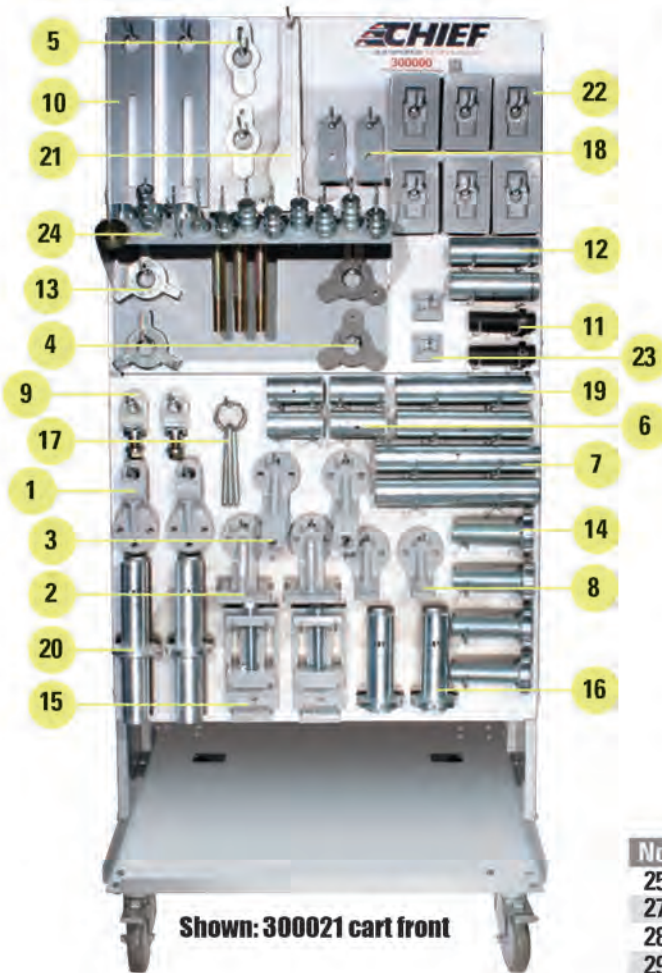

Shown: 300021 cart front

No.	Part No.	Qty.	Description
1	502000	2	Vertical Fixture Short
2	502005	2	Horizontal Fixture Large
3	502008	2	Vertical Fixture Tall
4	502014	2	Wing Nut, Parts Holding - LH
5	502015	4	Wing Nut, Parts Holding - RH
6	502016	4	4" Extension Tub
7	502017	2	12" Extension Tub
8	502019	2	Tall Horizontal Fixture
9	502026	2	Angle Adaptor Clamp Ass'y
10	502031	2	Base Plate
11	502033	2	Adapter, Parts Holding Lower
12	502034	2	Center Tub Parts Holding Turn Buckle
13	502038	2	Rigging Nut
14	502039	4	Structural Holding Adapter Ass'y
15	502042	2	Structural Vise Ass'y
16	502055	2	Short Tub Base Stand Ass'y
17	502058	4	Release Pin Ass'y
18	502060	2	Wrist Block
19	502061	2	10" Extension Tub
20	502063	2	Tall Tube Base Stand Ass'y
21	502067	1	Spanner Wrench Ass'y
21	502069	1	Spanner Wrench Ass'y
22	607371	6	Fastener Plate, UAS
23	638133	2	Jaw Clamp Ass'y
24	502062	1	Bolt Tray, Structural Holding

**Vertical fixtures** can mount to locations such as the suspension mounting areas creating a very strong hold for structural repairs.

**The large horizontal fixture** allows the ability to hold and control the end of a rail or structure for alignment or replacement of that component.

**The structural holding package** can be used to make **eight point holding** where needed with suspension in or out.

The system can be used for **Unitized and Full Frame vehicles** utilizing the vise clamp to hold full frame rails.

No.	Part No.	Qty.	Description
25	502070	1	Bolt Tray, Structural Holding, F150
27	640114	4	F150 Running Board Bracket Ass'y
28	640004	4	Weldment, Pinch Weld Base, F150
29	498110	4	Pinch Jaw with Nails Complete
30	640076	4	Formed Vertical Clamp, F150
31	640120	6	Weldment, Cab Mount, F150
32	640100	6	Support Plate, Cab Mount, F150
33	682953	4	Plate, EZ-Liner Tie Bolt

Shown: 300021 cart back

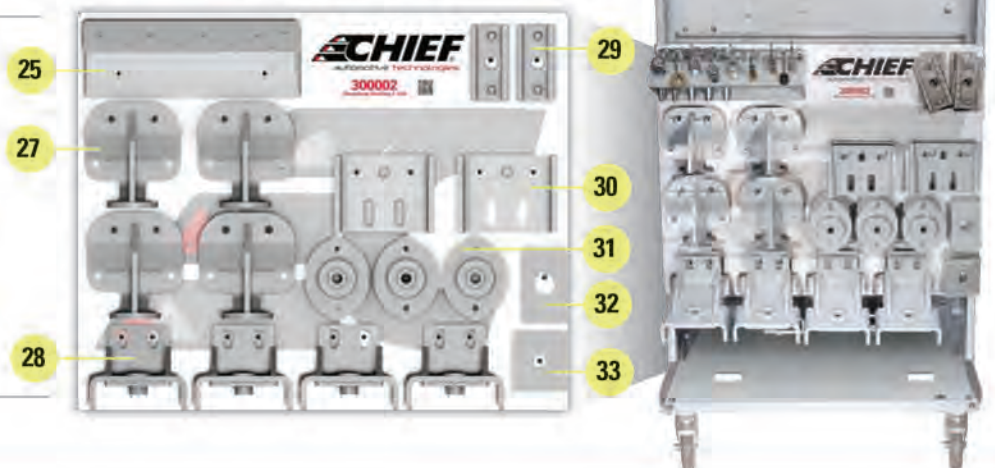

This **Tool Board** allows three ways to create holds for repairs:

The **Rigid Cab Mounts** are used to replace the rubber factory cab mounts during structural repairs.

Additional holds can be made when using the **90° Angle Pinch-Weld Jaws** that mount to the rocker flange inconjunction with the FAST Anchoring system.

A third method of holding is using the **Running Board Fixture** in conjunction with the base and fixture extensions within this parts package.

# TOOL BOARD PACKAGES



## FAST Anchoring System

**619202 – Wall Mount** Weight: 540 lbs. (245 kg)

**619203 – Cart Mount** Weight: 625 lbs. (284 kg)

Anchors the majority of pickup trucks, SUVs and full frame cars when used with Universal Anchoring System (UAS, USC) stands. Design allows broader anchoring points for measuring. Components either allow or prevent rail movement. The system's long crossbars can be rotated to match the slope of any attachment or frame rail.

No.	Part No.	Qty.	Description
1	539400	2	3.5 L Bracket
2	539404	2	7.5 L Bracket
3	539360	2	Chief Clamp Half
4	539365	2	Chief Clamp Base
5	539539	2	Tie-back Bracket
6	682953	6	Plate, EZ Liner Tie Bolt
7	539327	2	U-Bolt
8	539438	4	Spacer .125
	539407	2	Spacer .25
	539408	2	Spacer .5
	539409	2	Spacer 1.0
	539410	4	Spacer 2.0
9	539443	1	Hardware Holder
9a	539263	1 Pkg	Hardware Bolts Package
10	539423	2	Spring Shackle Assembly
11	539490	2	Vertical Clamp Assembly
12	628220	2	Turnbuckle Assist
13	539341	2	Spring Bolt Vise Assembly
14	539337	2	Narrow Rail Vise Clamp
15	508281	4	Universal Adapter Tube Without Clamps
16	539541	4	Riser Bar
17	539415	2	Long Crossbar

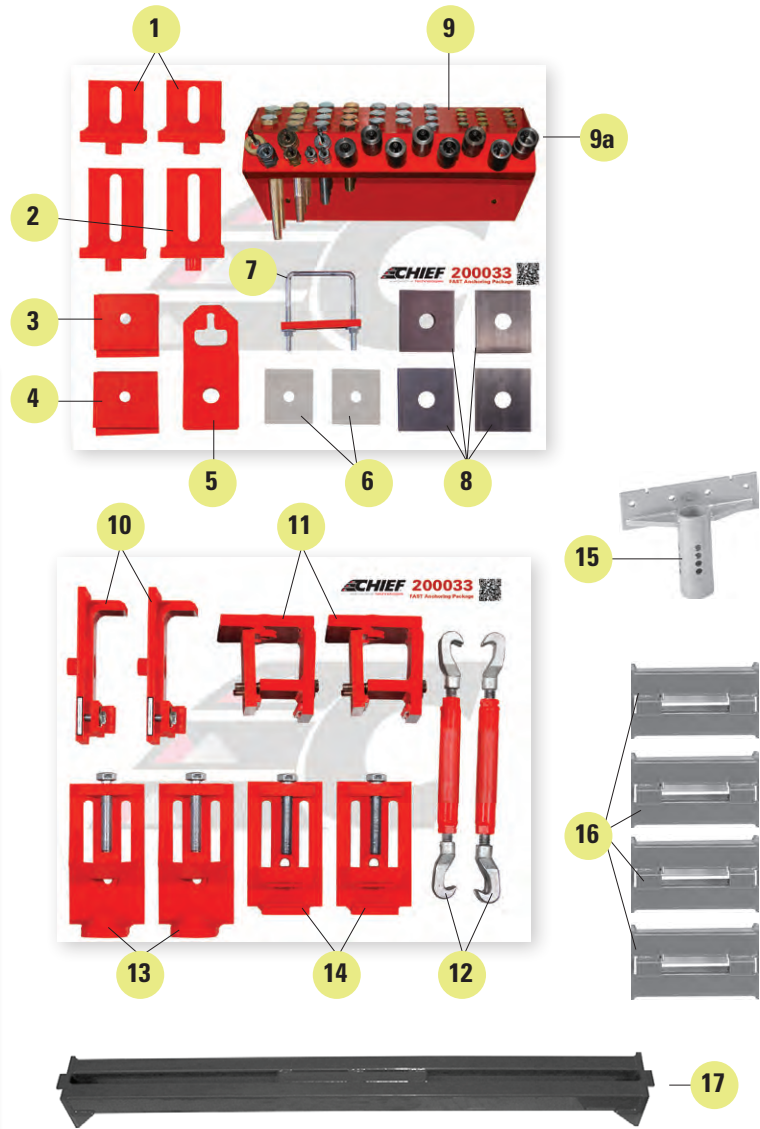

## Tool Board Cart

**619275** Weight: 100 lbs. (45.36 kg)

Chief Tool Boards may be wall-mounted or gain mobility by mounting them to this sturdy Tool Board Cart!

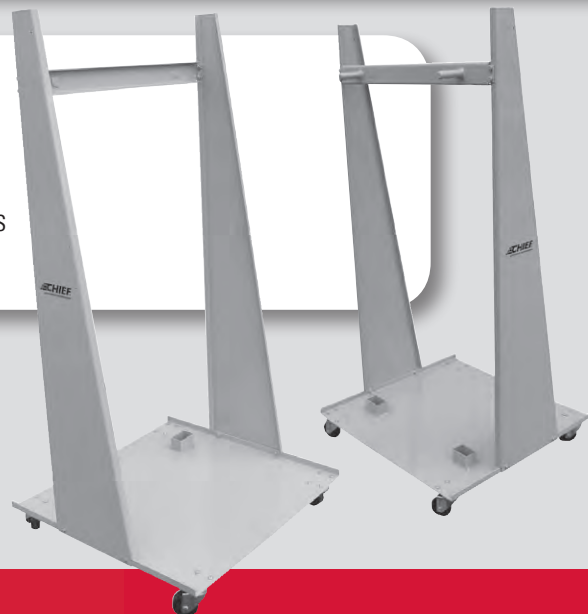

# TOOL BOARD PACKAGES



Chief Tool Board Packages feature the most innovative tools for repair.

Pulling accessories are available in various configurations, offering maximum versatility to keep pace with evolving automotive design. Make precise pulls on hundreds of unitized and conventional frame models while minimizing structural distortion.



## Deluxe Chain & Clamping Accessory Package

**619204** – Wall Mount  
Weight: 330 lbs. (150 kg)

**619205** – Cart Mount  
Weight: 400 lbs. (182 kg)

No.	Part No.	Qty.	Description
1	611880	1	Unitized Body Clamp
2	624235	2	Chief Attachment Side-Pull
3	672034	2	2" Self-Tightening Clamp
4	672000	1	1-1/2" Self-Tightening Clamp
5	CL1290CA	1	Chief Bite-Tight C-Clamp
6	CL0690CA	1	Chief Mini Bite-Tight Clamp
7	CL1590CA	1	Chief Angle Bite-Tight Clamp
8	697330	1	Down-Pull Attachment
9	MC6400	1	Regular Deep Hook Set, Mo-Clamp
10	619111	1	Boltless Strut Tower Puller
11	602896	1	Nylon Fender Strap
12	602909	1	Cable Sling
13	628220	2	Turnbuckle Assist
14	605261	2	Bumper Puller, w/18" Chain
15	610870	1	Pulling Plate, Right
16	610888	1	Pulling Plate, Left
17	619057	2	Slotted Chain Hook
18	602749	2	'T' Hook, w/18" Chain
19	602757	2	'R' Type Hook, w/18" Chain

No.	Part No.	Qty.	Description
20	611899	2	All-Angle Clamp
21	602853	2	Chain, Tie-Down, 3/8" x 4' w/Hook
22	602861	2	Chain, Tie-Down, 3/8" x 8' w/Hook
23	606548	2	Slotted Chain Anchor
24	610984	2	Chain Connector
	619289	4	Wall Board Frame
	619013	1	Users Manual, Self-Tightening Clamp
	619242	1	Board Assembly, Basic Clamping
	619271	1	Bolt Bag Package, Basic Clamping
	619214	1	Basic Clamping Layout Details
	619245	1	Board Assembly, Specialty Clamping
	619272	1	Bolt Bag Package, Specialty Clamping
	619215	1	Specialty Clamping Layout Details
	619248	1	Board Assembly, Basic Chain and Clamping
	619273	1	Bolt Bag Package, Basic Chain and Clamping
	619216	1	Basic Chain and Clamping Layout Details
	619251	1	Board Assembly, Basic Chain
	619274	1	Bolt Bag Package, Basic Chain
	619217	1	Basic Chain Layout Details

## Basic Clamping Package

619206 Weight: 45 lbs. (20.25 kg) – wall mounted

No.	Part No.	Qty.	Description
1	611880	1	Unitized Body Clamp
2	624235	2	Chief Attachment Side-Pull
3	672034	2	2" Self-Tightening Clamp
4	672000	1	1-1/2" Self-Tightening Clamp
5	CL1290CA	1	Chief Bite-Tight C-Clamp
6	CL0690CA	1	Chief Mini Bite-Tight Clamp
7	CL1590CA	1	Chief Angle Bite-Tight Clamp
	619013	1	Users Manual, Self-Tightening Clamp
	619242	1	Board Assembly, Basic Clamping
	619271	1	Bolt Bag Package, Basic Clamping
	619289	1	Wall Board Frame
	619214	1	Basic Clamping Layout Details (Install Sheet)



## Basic Chain & Clamping Package

619208 Weight: 177 lbs. (80.25 kg) – wall mounted

No.	Part No.	Qty.	Description
1	628220	2	Turnbuckle Assist
2	605261	2	Bumper Puller, w/18" Chain
3	610870	1	Pulling Plate, Right
4	610888	1	Pulling Plate, Left
5	619057	2	Slotted Chain Hook
6	602749	2	'T' Hook, w/18" Chain
7	602757	2	'R' Type Hook, w/18" Chain
8	611899	2	All-Angle Clamp
	619248	1	Board Assembly, Basic Chain and Clamping
	619273	1	Bolt Bag Package, Basic Chain and Clamping
	619289	1	Wall Board Frame
	619216	1	Basic Chain and Clamping Layout Details (Install Sheet)

## Basic Chain Package

619209 Weight: 60 lbs. (27 kg)  
– wall mounted

No.	Part No.	Qty.	Description
1	602853	2	Chain, Tie-Down, 3/8" x 4' w/Hook
2	602861	2	Chain, Tie-Down, 3/8" x 8' w/Hook
3	606548	2	Slotted Chain Anchor
4	610984	2	Chain Connector
	619251	1	Board Assembly, Basic Chain
	619274	1	Bolt Bag Package, Basic Chain
	619289	1	Wall Board Frame
	619217	1	Basic Chain Layout Details (Install Sheet)

## Specialty Clamping Package

619207 Weight: 45 lbs. (20.25 kg) – wall mounted

No.	Part No.	Qty.	Description
1	697730	1	Down-Pull Attachment
2	MC6400	1	Regular Deep Hook Set, Mo-Clamp
3	619111	1	Boltless Strut Tower Puller
4	602896	1	Nylon Fender Strap
5	602909	1	Cable Sling
	619245	1	Board Assembly, Specialty Clamping
	619272	1	Bolt Bag Package, Specialty Clamping
	619289	1	Wall Board Frame
	619215	1	Specialty Clamping Layout Details (Install Sheet)



# TOOL BOARD PACKAGES



## Small Pulling Package

619201 Weight: 50 lbs. (22.5 kg) 5 – wall mounted



No.	Part No.	Qty.	Description
1	602861	1	Tie-Down Chain, 3/8" x 8" w/Hook
2	602853	1	Tie-Down Chain, 3/8" x 4" w/Hook
3	606548	2	Slotted Chain Anchor, 3/8" Thick
4	611899	1	All-Angle Clamp
5	CL0690CA	1	Chief Mini Bite-Tight Clamp
6	CL1590CA	1	Chief Angle Bite-Tight Clamp
7	672000	1	1-1/2" Self-Tightening Clamp
8	672034	1	2" Self-Tightening Clamp
	619013	1	Users Manual, Self-Tightening Clamp
	619233	1	Board Assembly, Small Pulling
	619268	1	Bolt Bag Package, Small Pulling
	619289	1	Wall Board Frame
	619211	1	Small Pulling Layout Details (Install Sheet)

## Auxiliary Pulling Packages

### > Impulse Tilt

619218 – wall mounted  
Weight: 89 lbs. (40.5 kg)

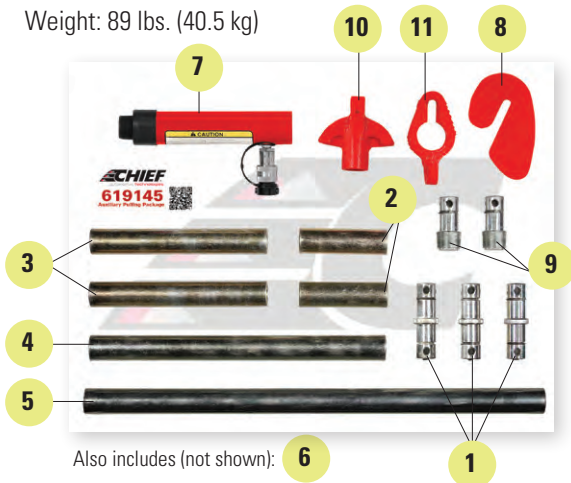

Also includes (not shown): 6

No.	Part No.	Qty.	Description
1	601834	3	Auxiliary Extension Coupling
2	601842	2	Auxiliary Extension, 6"
3	601850	2	Auxiliary Extension, 12"
4	601869	1	Auxiliary Extension, 20"
5	601922	1	Auxiliary Extension, 31"
6	602335	1	Ram V-Base
7	602360	1	Auxiliary Ram, 6" Stroke
8	606548	2	Slotted Chain Anchor
9	607849	2	Auxiliary Male Coupling
10	610829	1	Auxiliary Pulling Head
11	619057	1	Slotted Chain Hook
12	601140	1	Auxiliary Ram Base
13	601197	1	Auxiliary Ram, 6" Stroke with Quick Coupler
14	601213	1	Male / Klaw Assembly
15	601214	1	Female / Klaw Assembly
16	450441	1	Auxiliary Ram, 6" Stroke

### > S21M & Titan

619219 Weight: 114 lbs. (51.7 kg) – wall mounted 14

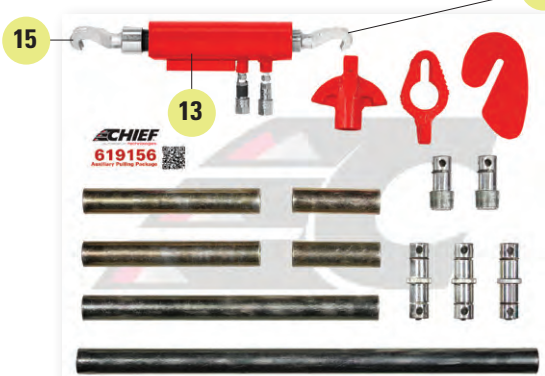

Also includes (not shown): 6 12

### > Impulse E/VHT

619200 Weight: 107 lbs. (48.5 kg) – wall mounted



Also includes (not shown): 12

# CAMELEON

## CAMELEON

CUSTOMIZABLE FIXTURE SOLUTION - UNIVERSAL | ADJUSTABLE

REF NO: CAM01.102 | CAM02.142 | CAM02.162



US 11,373,456 B2

# CAMELEON

# PREMIUM

CAM02.162

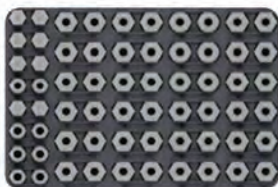
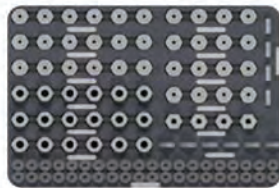



# WELDING



**CALL US TODAY**

**FOR THE BEST  
EQUIPMENT & SERVICE!**

(855) 999.SCCE



# MI300T

## THREE-PHASE SPOT WELDER

Chief's MI300T high performance spot welder is the ideal solution for all high strength steel body repairs.

### Easy to handle with reduced weight

Features the new GENIUS clamp allowing an automatic retraction of the electrodes for quick access of the welding area. Auto-mode allows welding without entering any parameters into the machine cutting welding time in half. Water lines automatically connect when changing arms reducing set up time.

### INTELLIGENT WELDING

**AUTO mode:** automatically recognizes steel type, sheet-metal thickness

### Multiple programs available:

Normal, Manual, Multi, Auto, Manufacturer and Energy

**Tracking** saves the characteristics of each welding spot to the SD card



Reversible clamp support

### Features:

- Watercooled power cables, electrodes and caps
- 5.7" LCD screen
- Automatic adjustment of pressure between electrodes
- Spot count feature to determine the caps lifetime
- 80 mm of automatic opening capacity (20 mm at rest)

### G1 arm features a motorized and adjustable overhanging arm with pulley.

- Easy to handle, the overhanging arm allows the height to be adapted to all working conditions.
- Extends 47" out and up to 100" up from the power source creating a wide working area.
- Rotates up to 30°
- Foldable to optimize space

### Available power supply:

MI300T #CELO69176 > 208V-240V / 40 amp fuse  
- 3 phase power

MI300T #CELO71223 > 480V / 20 amp fuse  
- 3 phase power

- Easy arm rotation – access hard to reach areas
- Automatic cooling connection
- Remote controlled clamp controls opening and welding adjustments

- Lockable Gyroscope  
– ball bearing, integrated into the clamp body
- Handle, lever and reversible clamp support (right or left)

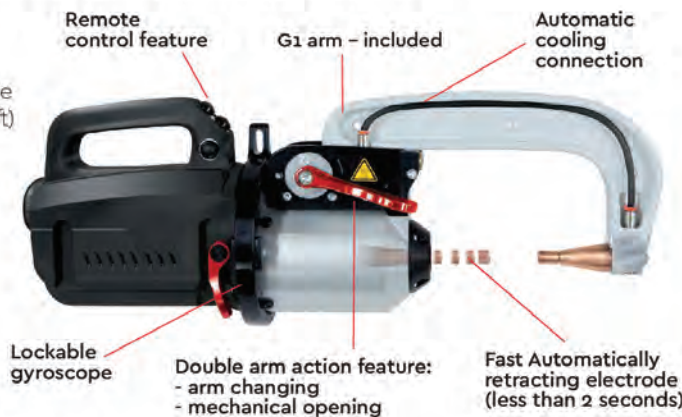

washers

### SPECIFICATIONS

Power Supply	208-240V or 480v
Fuse	40 A slow blowing for 208v 20 A for 480v
Frequency	50/60 Hz
Supply Power	14 kVA (80 kVA max)
Nominal Power by 50% ED	20kVA
Welding Current Max.	14,500 A DC (at 230V)
Electrode Force	550 daN with 8 bars (1236 lbf with 116 PSI)
Ambient Temperature	41° to 113° F (5° to 45° C)
Protective System	IP 21
Weight w/o Accessories	Approx. 220 lbs. (100 kg)
Pliers Weight	23.1 lbs. (10.5 kg)
Dimensions H / W / D	36.4" / 25.6" / 31.5" (92.5 x 65 x 80 cm)
Cable Length	Input mains cable: 26' (8m) Weld cable: 20' (6m)
Cooling Liquid Capacity	8 gallons (30 liters)

## MI300T standard equipment



MI300i unit



Monopoint electrode



Inertia hammer



Consumables box



Cap remover



Arm support

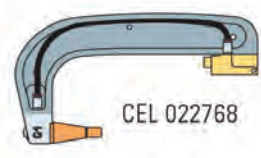

G1 Arm

## Optional arms

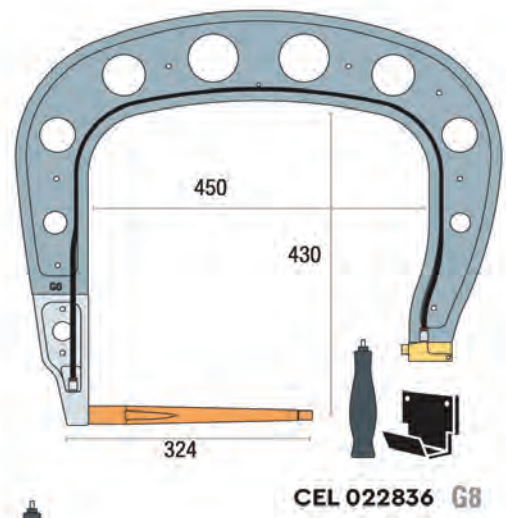
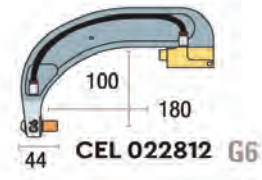
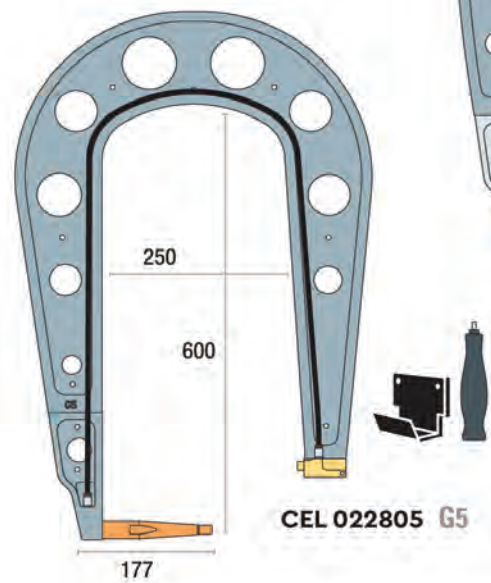
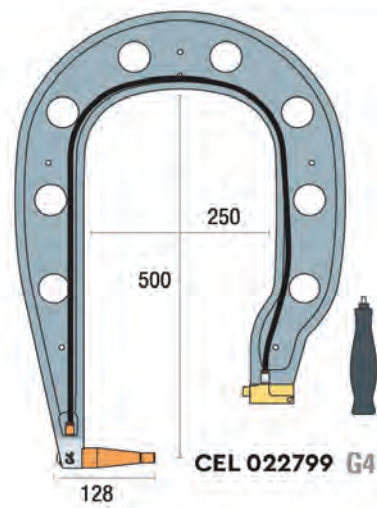
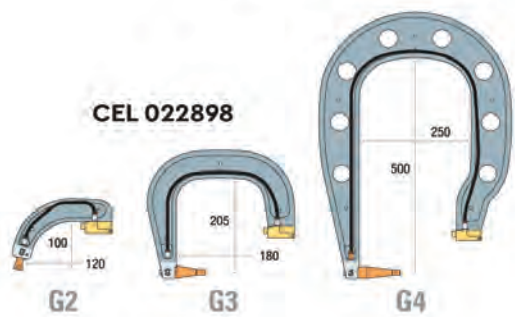
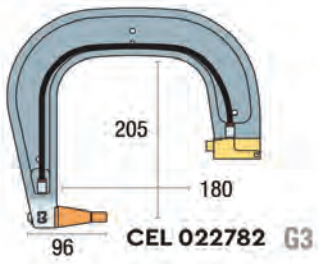
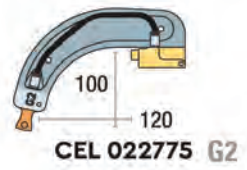
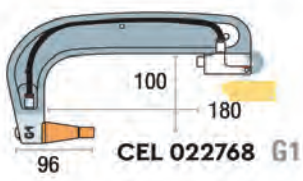

Improve the speed, quality and profitability of every repair you make.

©2021 VEHICLE SERVICE GROUP™  
 Printed in the U.S.A. All Rights Reserved. Unless otherwise indicated, CHIEF AUTOMOTIVE TECHNOLOGIES, VEHICLE SERVICE GROUP™, DOVER and all other trademarks are property of the Dover Corporation and its affiliates. Chief Automotive Technologies reserves the right to alter product specifications and/or package components without notice or liability, excluding changes to components subject to FCC & IC regulations.

CHIEF MI300T 08/21

NOTHING ELSE IS A  
**CHIEF**

**NEW!**

# MI200T™

**ELEKTRON TRUE AUTOMODE**

Chief's New MI200T Spot Welder is the ideal solution for all high strength steel body repairs.

- Simple to use LCD user interface
- Ergonomic and lightweight pliers
- Up to 14500A output power at 40% less input power\*
- High duty cycle without waiting for cool down
- Liquid cooled to the tips
- Nearly 20' of welding cable provides increased reach
- C-pliers with multiple size arms available

\*power usage compared to standard cable pliers welders



CEL025000



**THE NEW MI200T FEATURES A COMPACT  
TECHNICIAN FRIENDLY CONTROL PANEL**

### Elektron TrueAutomode:

- Detects and adjusts welding parameters
- Logs data for each repair
- Provides feed back on the results of every weld



# Every MI200T Comes Ready to Weld with this Standard Equipment:



Overhead Balancer



Insulated C1 Arm



360° Gyro C Arm



Arm Mounting Bracket



Starter Box of Caps

## Customize your Welder with These C - Arms:

Customize your MI200T with the multiple arms available for all of your welding needs.



**C1 Arm** (CEL019140)  
**Insulated C1** (CEL021402)

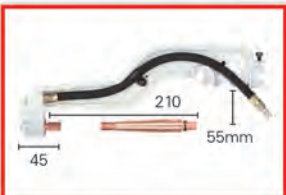

**C2 Arm** (CEL019133)  
**Insulated C2** (CEL022386)



**C3 Arm** (CEL019157)  
**Insulated C3** (CEL021419)



**C4 Arm** (CEL019164)  
**Insulated C4** (CEL021426)

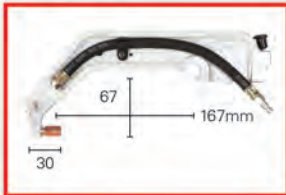

**C5 Arm** (CEL019294)  
**Insulated C5** (CEL022393)

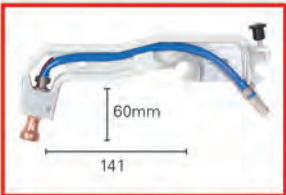

**C6 Arm** (CEL019775)  
**Insulated C6** (CEL022409)

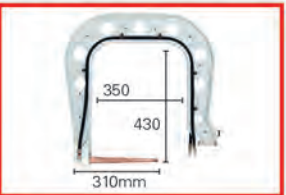

**C7 Arm** (CEL020009)  
**Insulated C7** (CEL021433)



**C8 Arm** (CEL020016)  
**Insulated C8** (CEL021440)

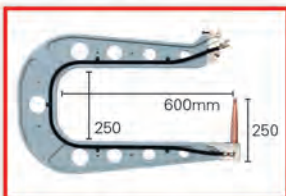

**Insulated C9** (CEL020078)

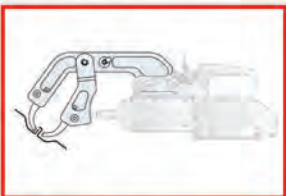

**C10 Arm** (CEL051638)



**C11 Arm** (CEL053649)



**Single Sided Kit** (CEL051010)



**C2 + Insulated C3 and C4**  
(CEL021457)



**C2 + C3 + C4**  
(CEL019126)



**C2 + C3 + C5 + C6 + Insulated C9**  
(CEL050044)

For Other Accessories Visit [chiefautomotive.com](http://chiefautomotive.com)

All C arms rated 550daN except C6 and C10.

**NEW!**



# MULTIMIG 525

*Welding and brazing of aluminum alloys, galvanized sheet metal, stainless, and high-strength steel.*

*Three standard MIG torches (one brazing, one aluminum, one steel) are mounted simultaneously with three different reels and wire.*

*Double Pulse feature - mechanically and electrically controls the welding parameters to achieve a TIG-looking weld bead making aluminum welding easier.*

## Features

- OEM required synergic pulsed technology - includes a complete set of programs
- Inverter technology enables precision control of output power
- Many programmable settings are available to customize the unit operation to meet most working conditions.  
Settings include: Hot Start, Crater Fill, Pre / Post Gas, Arc Length, 2T / 4T Start Mode, Spot / Pause function, Inductance, Burn Back, Soft Start, etc.
- Two regulators supplied

**INCLUDES Built-in cart  
for easy welder handling  
and storage for gas cylinder**

## SPECIFICATIONS

Single Phase Input	230V 50/60Hz + 15% to -20%
Supply Fuse Rating (slow blow)	16A
Input Power	6.3 KVA 20% 3.8 KVA 60% 3.1KVA 100%
Current Adjustment Range	20A to 200A
Duty Cycle (10 min 40°C) According to IEC 60974.1	200A 20% 140A 60% 120A 100%
Stepless Regulation	Electronic
Standard Supplied Synergic Programs	0.6/.08/0.9/1.0 Steel .08/0.9/1.0 Stainless 0.8/0.9/1.0/1.2 AL 0.8/0.9/1.0 CuSi3%
Max. Wire Spool Size	DIAM. 200 mm / 5kg
Protection Class	IP 23 S
Weight	232 lbs
Dimensions Inches	23 x 39 x 41h

# NOTHING ELSE IS A CHIEF

Welding and brazing of aluminum alloys, galvanized sheet metal, stainless, and high-strength steel.



**INCLUDES**  
Built-in cart for easy  
welder handling

#EL90001

Storage for gas cylinder



## DOUBLE PULSE TECHNOLOGY

- mechanically and electrically controls the welding parameters to make aluminum welding easier and for increased confidence

### Features, Advantages, Benefits

- Synergic pulsed technology is required by most OEMs for aluminum welding. Includes a complete set of synergic programs in memory for brazing, welding and aluminum wire.
- Inverter technology enables precision electronic control of output power for better welds.
- **GREEN technology** - Integrated Power Factor Correction (PFC) technology reduces input power by avoiding energy waste found in most electronic-based equipment and ultimately reduces operating costs.



**With the MultiMig 522, a Standard MIG torch and unique Push-Pull torch are mounted simultaneously with different reels and wire.**

- Two types of torches can be used with MultiMig power source - a standard MIG torch or the push-pull torch. The push-pull system torch has an up-down digital current adjust at your finger tip, thanks to a feeder built into the grip. The very small and light weight torch (no bulky spool-gun) enables real-time control of welding process by control of the wire feed speed and current level. The push-pull system corrects many of the problems encountered when feeding and welding soft aluminum wire, down to 0.6mm.
- Many programmable options are available to customize the unit operation to meet most working conditions. Options include: Hot Start, Crater Fill, Pre / Post Gas, Arc Length, 2T / 4T Start Mode, Spot / Pause function, Inductance, Burn Back, Soft Start, etc.



### SPECIFICATIONS

Single Phase Input	230V 50/60Hz + 15% to -20%
Supply Fuse Rating (slow blow)	30A
Input Power	5.7 KVA 20% 4.1 KVA 60%
Current Adjustment Range	15A to 200A
Duty Cycle (10 min 40°C) According to IEC 60974.1	200A 60% 160A 100%
Stepless Regulation	Electronic
Standard Supplied Synergic Programs	0.6/0.08/0.9/1.0 Fe, Stainless 0.6/0.8/0.9/1.0/1.2 AL 0.8/0.9/1.0 CuSi3 0.9 Flux core
Max. Wire Spool Size	Ø 200 mm / 5kg Ø 300 mm / 15kg
Protection Class	IP 23 S
Weight	165.3 lbs
Dimensions Inches	23.2 x 37.5 x 39.5h

Lit# CHIEF 522.10/16

©2016 VEHICLE SERVICE GROUP<sup>SM</sup> Printed in the U.S.A. All Rights Reserved. Unless otherwise indicated, CHIEF AUTOMOTIVE TECHNOLOGIES, VEHICLE SERVICE GROUP<sup>SM</sup>, DOVER and all other trademarks are property of the Dover Corporation and its affiliates. Chief Automotive Technologies reserves the right to alter product specifications and/or package components without notice, excluding changes to components subject to FCC & IC regulations.

# MULTIMIG 511

Part #EL900012 with Push-Pull Torch  
Part #EL900011 with Standard Aluminum Torch  
Part #EL900070 with Brazing Torch

***A push-pull torch designed specifically to optimize aluminum welding.  
Synergic pulsed welder with full set of welding programs!***



***Welding and brazing of aluminum alloys,  
galvanized sheet metal, stainless, and  
high-strength steel.***

The push-pull system has an up-down digital current adjust at your finger tip - enables real-time control of welding process. Programmable options are available to customize the unit operation.

**Features**

- OEM required synergic pulsed technology - includes a complete set of programs
- Inverter technology enables precision control of output power
- **GREEN technology** - Integrated Power Factor Correction (PFC) technology reduces operating costs.

***INCLUDES Built-in cart for easy welder handling and storage for gas cylinder***



Push-pull torch



Standard torch

**SPECIFICATIONS**

Single Phase Input	230V 50/60Hz + 15% to -20%
Supple Fuse Rating (slow blow)	30A
Input Power	5.7 KVA 20% 4.1 KVA 60% 3.2 KVA 100%
Current Adjustment Range	20A to 200A
Duty Cycle (10 min 40°C) According to IEC 60974.1	200A 20% 140A 60% 120A 100%
Stepless Regulation	Electronic
Standard Supplied Synergic Programs	0.6/.08/0.9/1.0 Fe, Alu 0.6/0.8/0.9/1.0/1.2 AL 0.8/0.9 Stainless Steel, CuSi3 0.9 Flux core
Max. Wire Spool Size	Ø 200 mm / 5kg Ø 300 mm / 15kg
Protection Class	IP 23 S
Weight	99.2 lbs
Dimensions Inches	18.9 x 33.7 x 32.5h

©2018 VEHICLE SERVICE GROUP<sup>SM</sup> Printed in the U.S.A. All Rights Reserved. Unless otherwise indicated, CHIEF AUTOMOTIVE TECHNOLOGIES, VEHICLE SERVICE GROUP<sup>SM</sup>, DOVER and all other trademarks are property of the Dover Corporation and its affiliates. Chief reserves the right to alter product specifications and/or package components without notice, excluding changes to components subject to FCC & IC regulations.

# MIG 240

## Synergic Mig Welder

*The MIG240 AUTO with Synergic Mode is a single phase MIG welder designed for welding steel.*

**NEW!**



### **Easy to use Synergic Technology**

The machine determines the optimum wire speed by selecting the type of wire, wire diameter, and welding current.

### **Welding parameters are automatically saved**

Memory save feature for each torch and activation of the 'last used' welding parameters (wire diameter, wire type and mode) are automatically saved.

### **Features, Advantages, Benefits**

- Wire reel motor with 4 drive rolls are suitable for 200mm and 300mm wire reels (15kg max)
- 3 welding modes available: Standard (2T) / Spot / Delay



SPECIFICATIONS	
Weldable wires	0.6 - 0.8mm
Welding Current, 60%	90A (40°C)
Duty Cycle I Max	140A 15% (40°C)
Welding current range	15 - 160 A
Mains voltage	208 / 240 V / 1Ph
Mains Fuse	16 A (CEE 16)
Dimensions D/W/H	470 x 770 x 790mm
Weight	110 lbs. (50kg)

©2018 VEHICLE SERVICE GROUP™ Printed in the U.S.A. All Rights Reserved.  
Unless otherwise indicated, CHIEF AUTOMOTIVE TECHNOLOGIES, VEHICLE SERVICE GROUP™, DOVER and all other trademarks are property of the Dover Corporation and its affiliates. Chief reserves the right to alter product specifications and/or package components without notice, excluding changes to components subject to FCC & IC regulations.





# MULTIMIG822

## THREE-PHASE MIG / MAG WELDER

The MULTIMIG 822 employs a MIG-MAG inverter power source with pulse and double pulse capability.

Weld and braze vehicles made completely, partly, or simultaneously of materials such as galvanized sheet metal, high-strength steels and aluminum alloys.

Two types of torches can be used – a standard MIG torch or push-pull torch with digital current adjustment.

Each is mounted with different reels and wire. 2 wire feed motors equipped with 4 aluminum rollers makes it possible to use 2 different wire spools, and keep 2 different types of torches mounted simultaneously with different wires.

### INVERTER / MIG-MAG WELDING

Inverter technology enables precision electronic control of output power for quality welds.

### Unit Includes:

- Set programs for welding and brazing of aluminum alloys, galvanized sheet metal, stainless, and high-strength steel
- Over 75 saved synergic curves, pulse and double pulse function
- Built-in cart for welder handling and storage for gas cylinder
- Support for 2 shielding gas bottles
- 5" display LCD screen
- 4-roller wire feeder
- 300 mm and 200mm spool compartments
- Up / Down PUSH-PULL torch connection for adjustment



Standard MIG torch



Adjustable air cooled push-pull torch

### SPECIFICATIONS

Three Phase Input	208-480V 50/60 Hz + 15% to -20%
Supply Fuse Rating	16A
Input Power	9.0 kVA 20% 8.3 kVA 40% 6.3 kVA 60% 4.9 kVA 100%
Current Adjustment Range	20A to 270A
Duty Cycle (10 min 40°C) According to IEC 60974.1	270A 20% 250A 40% 220A 60% 180A 100%
Stepless Regulation	Electronic
Synergic Programs	0.6/.08/0.9/1.0 Fe, Stainless 0.6/0.8/0.9/1.0/1.2 AL 0.8/0.9/1.0/1.2 Inox 0.8/0.9/1.0 CuSi3
Max. Wire Spool Size	Ø200 mm / 5kg Ø300 mm / 15kg
Protection Class	IP 23 S
Weight	167 lbs.
Dimensions / Inches	23" w x 37" t x 39" h



Improve the speed, quality and profitability of every repair you make.

# WELDING HELMETS



Lincoln Viking 3350 4C Matte Black 4th Gen Welding Helmet



Miller Classic Series Welding Helmet w/ ClearLight Lens, Black



ESAB Sentinel A60 Welding Helmet



3M Speedglas Welding Helmet - 9100XXi Auto Dark Lens



GYS Air Fed Helmet Gysmatic 5/13 XXL True Color



# COLLISION CENTER TOOLS



**CALL US TODAY**

**FOR THE BEST  
EQUIPMENT & SERVICE!**

(855) 999.SCCE

# LIFT KING LIGHT DUTY

## THE SOLUTION FOR INSTANT OEM PICKUP BOX REMOVAL AND INSTALLATION

The Lift King Light Duty Package comes with everything needed to remove or install OEM pickup boxes of all sizes including 8' dually boxes.

Once the pickup box is disconnected and ready for removal, the Lift King Main Component converts from the stored position to the working position within 1 minute and with little effort. There are no tools needed. The Main Component is then connected to the pickup box, and the box is removed in less than 5 minutes, including the original setup time.

This application requires no human lifting of any type and only one technician of any size or strength for pickup box removal or installation.



# LIFT KING HEAVY DUTY

## THE SAFEST TOOL FOR RELOCATING FIBERGLASS AND ALUMINUM

The Lift King Heavy Duty Package comes with everything needed to remove or install semi hoods of all sizes including fiberglass and aluminum.

Once the semi hood is disconnected and ready for removal, the Lift King Main Component converts from the stored position to the working position within 1 minute and with little effort. There are no tools needed. The Main Component is then connected to the semi hood, and the hood is removed in less than 5 minutes, including the original setup time.

This application requires no human lifting of any type and only one technician of any size or strength for semi hood removal or installation.



# LIFT KING COMBO

## THE ULTIMATE PACKAGE FOR REPAIRS OF ALL SEMI-TRUCK HOOD SIZES

The Lift King Combo Package is a great option for shops that work on both automotive and commercial trucks.

This package includes everything needed to remove and install pickup truck boxes, including 8' dually's, and semi-truck hoods of all sizes, including fiberglass and aluminum.

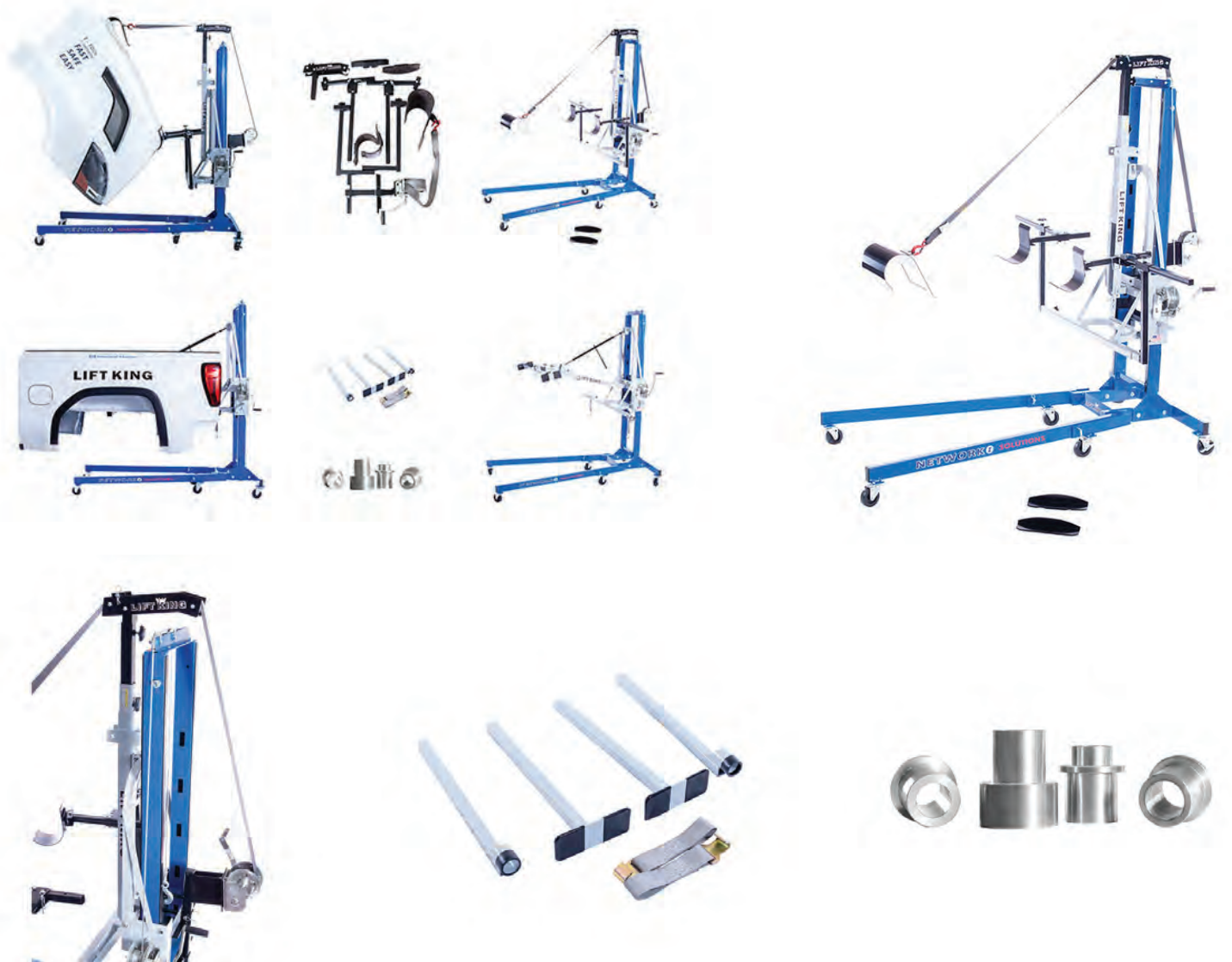



## Lift King Extreme Stand

The Extreme Stand is a great choice when painting hoods, fenders, bumpers, doors, liftgates, deck lids, and many other panels.



## Lift King Door Attachment

This is the safest and most efficient way to remove or install automotive, commercial, and fleet truck doors of all sizes; large and small.



## Lift King Painter's Package

More information on each of these paint stands can be found on their individual product pages.





## Lift King 5th Wheel Attachment

The Lift King 5th Wheel Attachment connects to the Main Component within seconds. This is a great option when removing or installing 5th wheels for commercial and pickup trucks



## Lift King Wheel Attachment

The Lift King Wheel Attachment is a great feature for all collision and mechanical shops performing repairs that require a wheel or tire to be removed or installed.



## Lift King Wheel Dolly Package

The Lift King Wheel Dolly Package comes with four sets of our Wheel Dollies plus a Wheel Dolly Rack for easy, space-saving storage.

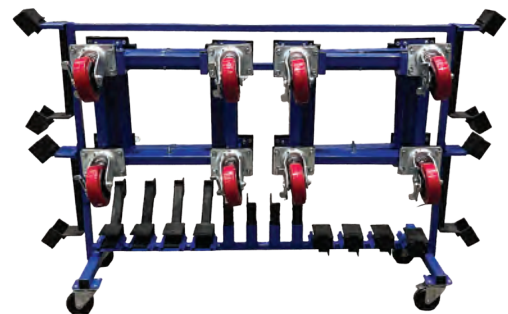



# VULCAN ADU

## Adhesive Debonding Unit

### ***BREAK THE BOND OF ADHESIVE***

- Chief's Vulcan ADU can break the adhesive bond on any vehicle surface; steel, aluminum, and carbon fiber using no electromagnetic field.

- Breaks the adhesive bond between glued panels or surface
- Precise temperature control - focus on one panel layer
- Microprocessor control with color touch screen
- Air and water cooled lamp for safety and extended life
- Uses infrared lamps to output focused heat to a surface
- Calibration feature to address issues when measuring different color paint and reflectivity
- Can be used to remove molding and labels
- 5-step program available to set temperature and time for curing adhesives



**THE VULCAN ADU  
INCLUDES CART  
AND COOLING UNIT**



SPECIFICATIONS	VULCAN
Voltage	230V - 60Hz (three phase)
User Interface	Color Display Touch Screen
Cable length	4M
Adjustment	Power, Time and Temperature
LAMP	
Power Output	4.8kW
Lamp Life	5000h
Cooling System	Compressed Air and Chilled Water
Temperature Control	Pyrometer
Accessories	Temperature Calibrator Trolley 3461T

# HEAVY DUTY Rivet Gun

*The perfect solution for riveting operations in thin sheet metal structures.*

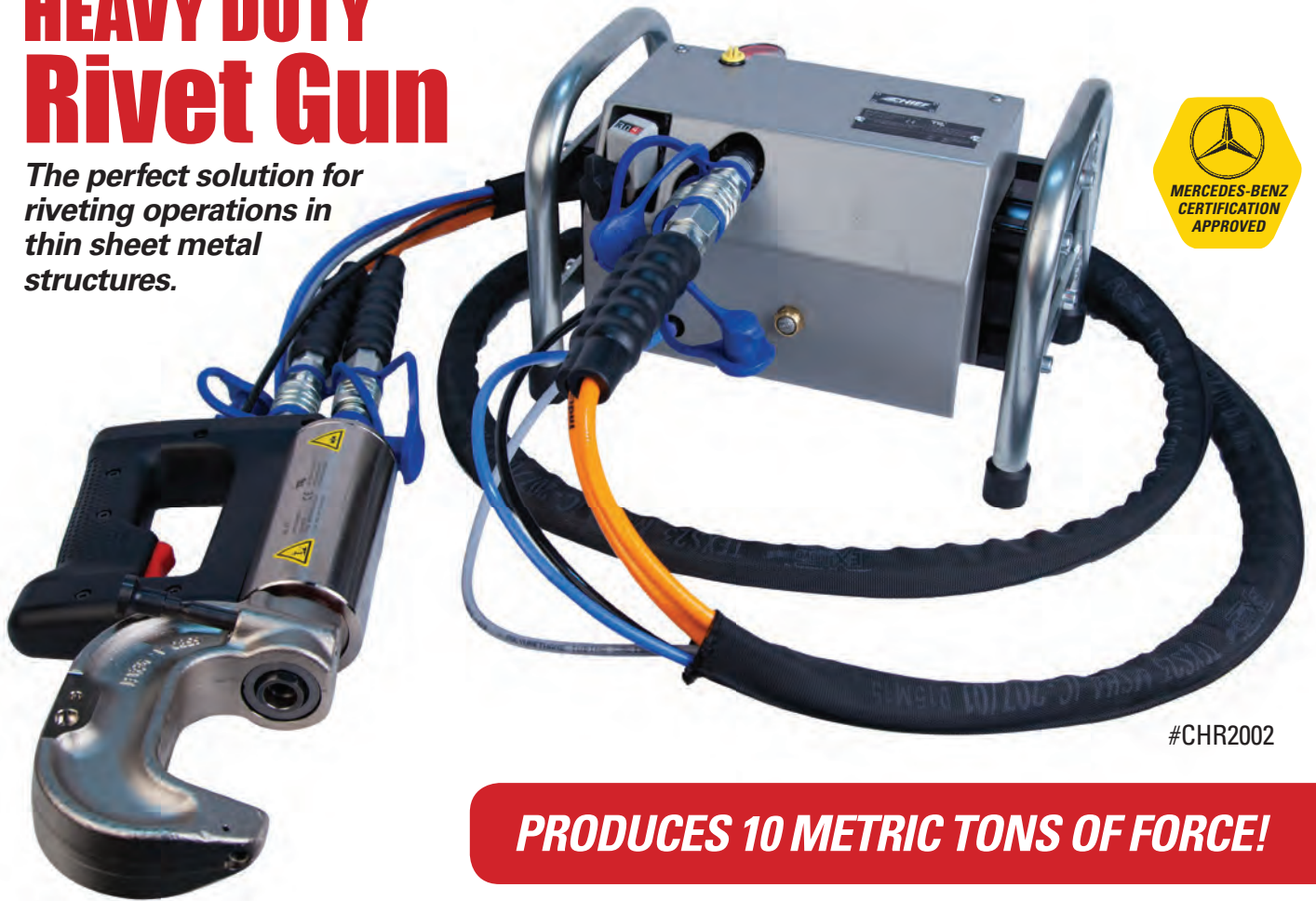

#CHR2002

**PRODUCES 10 METRIC TONS OF FORCE!**

*The HD rivet gun is the strongest mobile hydraulic tool for bodywork repair with double acting hydraulics that can drive 10 tons of compressive force and retract with 8 tons of tension force.*

Specifically developed for riveting sheet metal in the autobody repair field where high insertion force is needed. Chief's rivet gun is a pneumatic-hydraulic system for riveting and pressing out self-piercing rivets. Universal technology enables adaption of various attachments for different applications. Easy to use and highly efficient - this riveting tool allows technicians to complete repairs in record time.

## **Features / Advantages / Benefits**

**Accepts universal attachments for various applications:**

Riveting / Punching / Calibrating / Pressing Out / Forming

**10 metric tons of compression force** (22,000 lbs.)  
and 8 metric tons of retraction force

**Highly efficient** - hydraulic pressure ratio of 100:1

**Adjustable, precise control** over strength of compression

**Sturdy construction** with long life and low maintenance



*All extensions are based on the PNP 90 UN 2.0 and compatible with existing riveting tool.*

## Basic Rivet Gun Kit Includes:



**Hydraulic Gun  
DN4-XT<sup>2</sup>**  
#CHR2411H



**Pressure Intensifier  
PNP90 SNW XT<sup>2</sup>**  
#CHR2410H



**Kit 1 - Punching**  
Ø6mm + Ø8mm  
#CHR2415H

### Riveting X<sup>2</sup> Tool Kit



**Kit 2 - Flow form rivets**  
Forming, SPR-Extraction  
Ø6mm + Ø8mm  
#CHR2416H



**Rivet Clamp  
NB 45**  
#CHR2412H



**Adapter  
PNP90 to XT<sup>2</sup>**  
#CHR2417H

## ACCESSORIES



**Rivet Clamp NB 130**  
#CHR2430H



**Rivet Clamp NB 240**  
#CHR2431H

### Specifications - Rivet Gun Technical data

#### Pump PNP90 SNW XT<sup>2</sup>

Length	12-63/64" (330mm)
Width	10-15/64" (260mm)
Height	8-25/64" (213mm)
Weight	23.4 lbs. (10.6 kg)
Max. input pressure	6 bar / 87 PSI
Max. operating pressure	600 bar / 8700 PSI

#### Hydraulic Actuator HA XT<sup>2</sup>

Length x Width x Height (including handle)	11-1/32 x 2-9/16 x 7-9/32" (280 x 65 x 185mm)
Weight	10.2 lbs. (4.6 kg)
Max operating pressure	600 bar / 8700 PSI
Travel	1-31/32" (50mm)
Max. setting force "extend"	100 kN (22,481 lbf)
Max. setting force "retract"	80 kN (17,985 lbf)

### Specifications / Rivet Gun Accessories

#### RIVET CLAMP NB 130

Length	9-1/16" (230mm)
Width	2-61/64" (75mm)
Height	8-17/64" (210mm)
Clamp Opening	3-5/32" (80mm)
Opening Depth	5-1/8" (130 mm)
Weight	13.1 lbs. (6.2kg)

#### RIVET CLAMP NB 240

Length	15-23/64" (390mm)
Width	2-61/64" (75 mm)
Height	13-25/32" (350mm)
Clamp Opening	5-33/64" (140 mm)
Opening Depth	9-29/64" (240 mm)
Weight	25.9 lbs. (11.6 kg)

# Rivet Gun

Easy to use, lightweight  
and highly efficient

*This riveting tool allows your technicians to complete all common riveting operations in thin sheet metal structures in record time.*



#CHR2001

## Perfect Rivet Every Time.

Chief Rivet Guns allow you to quickly restore cars, trucks and heavy duty vehicles back to factory specifications with a professional and seamless finish. With durable construction, a variety of attachments the rivet guns can handle any job you throw at them.

Specifically developed for riveting sheet metal in the autobody repair field, this rivet gun is a pneumatic-hydraulic system which easily adapts various attachments for different applications. The hydraulic pump is pneumatically driven. The pressure intensifier, with a ratio of 100:1, delivers hydraulic output pressure of 8702 psi (600 bar) with input pressure of only 87 psi (6 bar). When the equipment's preset final pressure is reached, the pump stops and maintains constant pressure, using a pneumatically controlled pressure regulator.

## Features, Advantages, Benefits

**Universal** - allows for attachments for various applications:

Riveting / Punching / Pressing Out / Calibrating

**Highly efficient** - pressure ratio of 100:1

**Precise control** over strength of impact

**Sturdy construction** with low maintenance

*The basic tool kit contains the pneumo-hydraulic pressure intensifier a hydraulic gun, an NB 40 rivet clamp and a fully equipped UN 2.0 Riveting Tool Kit.*



# BASIC RIVET GUN KIT



**Rivet Clamp  
NB 40**



**Hydraulic Gun  
HP 35 UN**



**Pressure Intensifier  
PNP90**



**Riveting Tool Kit  
Locking Bolts**



**Case**

1x Pressure intensifier PNP90

1x Hydraulic gun HP 35 Un

1x Rivet clamp NB 40

- Length x Width x Height - 4-11/64 x 1-49/64 x 6-17/64" (106 x 45 x 159mm)
- Weight - 3.4 lbs. (1.5 kg)
- Clamp Opening - 3-5/32" (80mm)
- Opening Depth - 1-37/64" (40mm)

1x Riveting tool kit RIVKIT - UN 2.0

- Setting / closed head 1/8" (3mm) rivet
- Setting / closed head 13/64" (5mm) rivet
- Setting / closed head, flow form rivet
- Punch and calibration mandrel / die
- Extraction mandrel / die
- Replacement elastomer rings
- Set of mounting tools
- Spacing adaptor

2x Locking bolts

## Optional Accessories



**Rivet Clamp NB 115 #CHR2204**



**Rivet Clamp NB 230 #CHR2203**

### Specifications - Rivet Gun

#### Technical data

#### Pump PNP90 UN 2.0

Length x Width x Height (without hoses, including handle)	12-63/64 x 9-1/16 x 8-25/64" (330 x 230 x 213mm)
Weight (without hoses)	17.1 lbs. (8kg)
Max input pressure	6 bar / 87 PSI
Max operating pressure	600 bar / 8702 PSI

#### Hydraulic gun HP 35 UN

Length x Width x Height (including handle)	9-11/16 x 1-31/32 x 4-9/64" (246 x 50 x 105mm)
Max operating pressure	600 bar / 8702 PSI
Travel	19/32" (15mm)

### Specifications / Rivet Gun Accessories

#### RIVET CLAMP NB 115

Length* x Width x Height	8-25/64 x 1-47/64 x 8-21/32" (213 x 44 x 220mm)
Weight*	6.9 lbs. (3kg)
Clamp Opening	3-5/32" (80mm)
Opening Depth	4-17/32" (115mm)

#### RIVET CLAMP NB 230

Length* x Width x Height	14-21/64 x 1-49/64 x 13-45/64" (364 x 45 x 348mm)
Weight*	20.15 lbs. (9.5kg)
Clamp Opening	5-33/64" (140mm)
Opening Depth	9-1/16" (230mm)
Length spacer	3-5/64" (78mm)

# Tool Kit PNP 90 XT2



The basic tool kit comprises the pneumo-hydraulic pressure intensifier PNP 90 SNW XT<sup>2</sup> and a hydraulic actuator HA XT<sup>2</sup> with duo-hose package. The kit can be supplemented with rivet clamp NB 45 and two fully equipped riveting tool kits for punching, pressing, calibrating, shaping and flow forming.

The hydraulic pump is a pneumatically driven pressure intensifier with a pressure ratio of 1:100. This means that hydraulic output pressure of 600 bars is generated with input pressure of 6 bars. When the equipment's preset final pressure is reached, the pump stops automatically and keeps the pressure constant. The hydraulic pump has a pneumatically controlled pressure relief valve.

## Contains:

- PNP 90 SNW XT<sup>2</sup> with pressure limitation
- Hydraulic actuator XT<sup>2</sup>
- Rivet clamp NB 45
- Hose package Duo, DN4
- Handle M8
- Instruction manual, without fig.
- Riveting tool kit Kit 1 „Punching“
- Riveting tool kit Kit 2 „Flow form rivets“
- Adapter kit 60 kN

# Glenair Ground Rivet Tool

The easy to use, reliable  
earth bond system  
Drill, Insert, Expand, Connect

- ✓ Lightweight hydraulic setting tool.
- ✓ Requires no welding, impacting, cleaning or surface preparation.
- ✓ Quality repeatable termination even to uneven and curved surfaces.
- ✓ Consistent connection providing low electrical resistance.
- ✓ Bond is installed from one side only.
- ✓ Available for aluminium and steel plates from 1.5mm thick and upwards.
- ✓ High strength joint.



# Battery Riveting Machine ER20



The ER20 riveting machine is a powerful battery operated tool for blind riveting up to 6.4 mm diameter (all materials), especially for structural automotive rivets. With a setting pressure of 20,000 N and a very large stroke of 30 mm, it is also possible to install blind star riveting nut reliably and quickly.



## **Contains:**

- 1 carrying case
- 2 20V batteries
- 1 charger
- 1 box of nose pieces
- 1 assembly wrench



# Milwaukee Tool

## M18 FUEL 1/4" Rivet w/OK Kit

Fastest cordless riveting tool in the market.



This tool offers 3X more extended tool and jaw life, decreasing high energy costs, the time spent on maintenance and the hassles of using compressors & hoses to run pneumatic rivet tools.

# RV700 | 9 TON

RV.700 | RV.700.01

ELECTRO-HYDRAULIC BATTERY OPERATED RIVETING SYSTEM  
DIG SYSTEM

## RV.700

8 ton electro hydraulic battery operated riveting system with digital control equipped with C-arm and universal set of dies without battery and battery charger

## RV.700.01

8 ton electro hydraulic battery operated riveting system with digital control equipped with C-arm and universal set of dies with battery and charger



Adjustable operating pressure electronically



Built in software for recording and printing report of every rivet insertion.

KIT.R/



## Technical features

Light, compact, and portable pump body  
Powered using an 18V Lithium Ion battery  
Operator adjustable compression force from 20 kN to 90 kN  
Compression head rotates 360°

Option of 3 different compression arms 40mm, 130mm, 240mm  
Pump weight 3.8Kg/8.31bs  
Display with real time information on pump set up and actual compression force

## Oem official approvals



\*All logos, names, brands, trademarks and registered trademarks are property of their respective owners. They are used all for identification purposes only

## Optional



RV.193

140 mm



RVMR



RV.192

80 mm



RVMB



DD.403

# RV/EP02 | 9 TON

RV.EP02 | RV.EP02.01

ELECTRO-HYDRAULIC BATTERYOPERATED RIVETING SYSTEM



## RV.EP02

90 kN electro-hydraulic gun riveting machine with C-arm and universal die | without battery and battery charger

## RV.EP02.01

90 kN electro-hydraulic gun riveting machine with C-arm and universal die kit with battery and battery charger

## Technical features

- Strong light weight construction
- Compression head rotates 360°
- Option of three different compression arms: 40mm, 130mm, 240mm
- Weights 5Kg / 11lbs
- 18V Lithium Ion battery included

## Oem official approvals



\*All logos, names, brands, trademarks and registered trademarks are property of their respective owners. They are used all far identification purposes only

## Optional

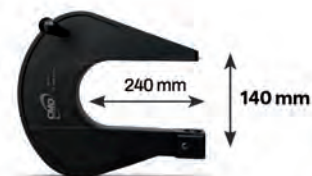

RV.193



RVMR

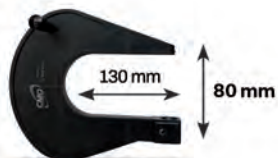

RV.192



RVMB

RV.EP02.ADT

Adattatore per | Adaptor for RV.MR / RV.MB

DD.403



**Automatic air powered riveter specially designed to perform common riveting tasks in modern bodyshops including self-piercing rivets and standard flow form rivets.**

## ACCURATE SETTINGS

The user can manually adjust the **actuator speed** as well as **rivet pressure** according to the metal used in order to avoid panel distortion.



Speed control



Pressure control  
0 > 6.5 bar

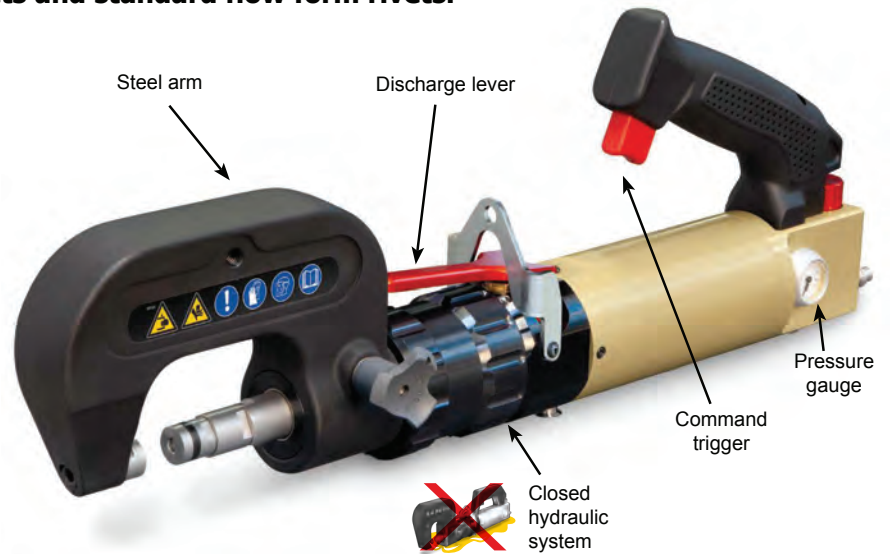

## ERGONOMIC AND EFFICIENT

- Maximum pressure of **10 tonnes** with integrated pressure gauge. **Fast** and **easy** arm change.
- C-arm **swivels 360°** around the riveting machine axle.
- Selection of arms available for **difficult access situations**.
- Easy to use **ergonomic handle** and **trigger**.
- **Magnetic die** makes rivet positioning easy.

### Delivered with :

- 2 die keys
- 1 strap
- 1 arm HR110
- 1 handle for arm
- 1 box of rivets



- + 1 standard die kit for extraction and rivet positioning
- + Centre punch :
  - self-piercing (ø 3.3 et 5.3 mm)
  - flow-form (ø 5.6 mm)



## ACCESSORIES





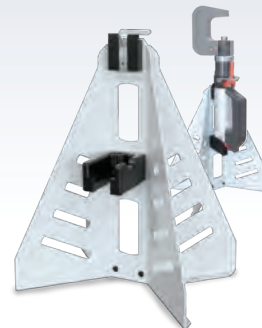
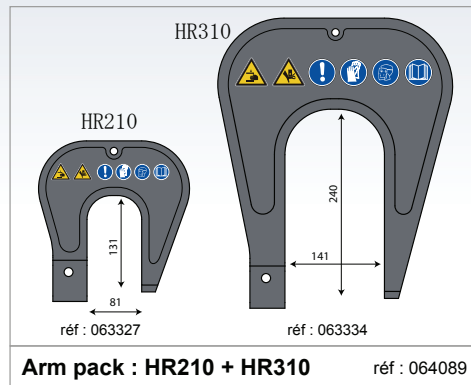



**HR110 arm**  
réf : 063310



**Support**  
réf : 054158



**GYPRESS 8T Workstation**  
réf : 054233

				HR110	HR210	HR310	Cycle time	AIR BAR
							4 sec	normal 6.5 maxi 10
39.5 x 180 cm	58 x 48 x 15 cm	11.8 kg	4 kg	3 kg	5.4 kg	12 kg		

Fitted with a smart user interface for choosing different dies and Synergy settings, the **WORKSTATION GYSPRESS 10T PP CONTROL** is the riveting station of the future. The Push-Pull system allows the machine to install all types of manufacturer-specific rivets (self-punching rivets, Flow-Form rivets and solid rivets, etc.). The careful technical regulation of the riveting force guarantees perfectly accurate rivets every time. The traceability features meet the demands of even the most demanding manufacturers.

## USER FRIENDLY AND EFFICIENT

- Maximum force of 100 kN that can be easily adjusted with excellent precision (+/- 2.5%).
- Quickly and easily change the riveter's arm.
- Two control buttons: one button is for riveting and the other button is for opening the riveting machine or extracting the punches.
- The C-arm can be rotated 360° around the riveting machine's axis.
- Several arms to give access to all vehicles in all situations.
- Excellent grip thanks to its ergonomic handle and single-finger trigger.

■ **Push-Pull System:** This latest innovation facilitates removing the dies after piercing the sheet metal thanks to its unique stripping system.

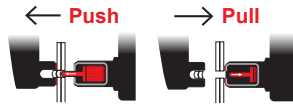

## SMART RIVETING

- **SYNERGIC mode:** The product's interface guides the user on the dies to be used, as well as the required force, depending on the type of rivet being placed.
- **Traceability:** This machine is able to record riveting operations for completely accurate traceability.
- Playback recorded reports on a PC.

## REGULATING THE SETTING FORCE

- A built-in hydraulic pressure sensor allows the riveter to check that the required installation force has been achieved.

## MULTI-BRAND

- Designed for repairing numerous makes of vehicles (VW Group, Mercedes-Benz, BMW, Tesla, Ferrari, Ford and General Motors, etc.).

## ROBUST AND MOBILE





- Reinforced casing and manoeuvrable trolley with built-in storage unit.
- Spacer on the front wheels for even better stability.
- Integrated three-arm support.

### ■ Included



### ■ Optional Extras



	HR110	HR210		HR310	Time to cycle	AIR BAR			
4 kg 46 x 15 x 10 cm	3 kg	5.4 kg	12 kg		4 sec	normal 6.5 maxi 10	74 x 116 x 50 cm	73 x 39 x 90 cm	54 kg



# 5T POWER GUN

BODY ALIGNMENT TOOL

Perform vehicle repairs with this patented pushing and pulling car body alignment tool.

With up to 5 tons of standard power, the 5T POWER GUN allows a greater capacity to move stronger panels and do heavier repairs.



With a single hand, this battery operated power gun provides the most convenient metal re-alignment capabilities

With no cords, hoses or hand pumps needed, techs can make repairs inside and outside of the vehicle faster with this versatile auto body repair gun system.

## EASY TO USE, ONE-HANDED OPERATION!

Traditional porto-power requires a tech to have a hand on the pump and ram, making it difficult to do most repair tasks. Perform a greater variety of repairs and in more vehicle areas with the push and pull power of the 5T Gun versus manual porto powers that can only pull.

## FRAME RACK VERSATILITY

Use the gun as an additional tower on any frame rack and increase repair versatility by adding holding or pulling as needed. Free up rack space by using this power gun for light pulls instead of taking up valuable space on a frame rack.

Perform these pressing and pushing methods of re-aligning body parts and structures with the push of a button. The included accessory kit generates a wide range of repair options.





**#EL920032  
STANDARD KIT**



**STANDARD KIT APPLICATIONS**

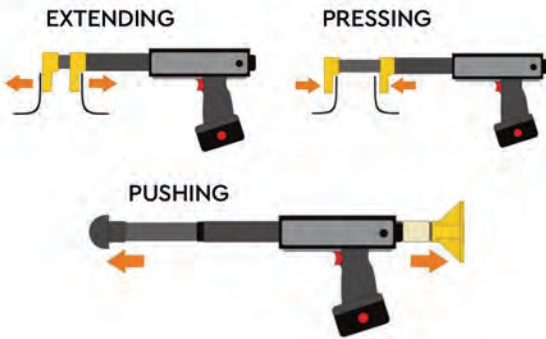

**#EL920033  
ACCESSORY KIT  
INCLUDED WITH PURCHASE**



**ACCESSORY KIT APPLICATIONS**

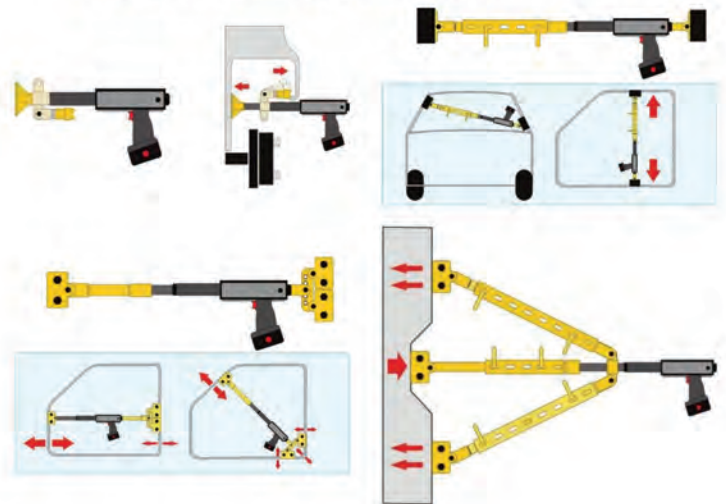

# MOTIONLED ESTIMATOR LIGHT

BETAG's MotionLED 33 Estimator light makes it quick and easy for estimators to observe and accurately identify all damages on the vehicle at check in - particularly small dents & scratches that are often missed.

## Features:

- Lightweight & Portable
- Battery operated, no extension cords needed 10 to 12 hours operating time on one charge
- Recharge to full capacity in 7 to 8 hours
- Light color can be alternated between warm and bright - works great on any vehicle color
- For indoor or outdoor use

## Tech Specs:

- Handle Length: 87cm; effective range of the light from the handle is around 60cm
- Light Dimensions: W 34cm x H 17cm
- Weight:
  - Light: 600g
  - Handle: 1.1 kg





# MOTIONLED & EXTENDER ARM

BETAG's lighting systems are equally valuable for estimators, repair planners, and technicians. Estimators use them to more easily identify and mark all the damage on a panel; and produce much higher quality images of the damage to submit to the customer or insurer.

Specialized task lighting transforms the way in which PDR and autobody technicians can straighten panels, enabling them to deliver higher-quality work, more quickly and efficiently.

The MotionLED has an integrated battery, providing 8 hours of continuous runtime. Color temperature may be changed from warm to cold light, as well as individual control (on/off) of each light strip. It may also be used or charged with an external battery or mains power.

## Advantages:

- Integrated battery
- 8 hours runtime
- Easy to adjust
- Easy to assemble/disassemble
- Wide, continuous light band
- Independent control of each light strip
- Warm and cold light strips
- 360-degree rotation
- Lightweight (7Kg)

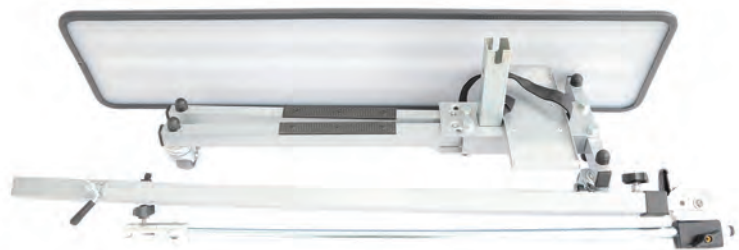

Battery Powered Motion LED: **BETAG 8421**



Extension Arm: **BETAG 8446**

# GUNIWHEEL FAST PULLER XL

Lightweight and portable dent puller. Fixed to the ground through vacuum suction and made of aluminum makes for a light and easy transport. Use at any workstation. 550 lbs pulling power.



## **BENEFITS**

- Easily move between work bays
- No waiting for open work bay – pull dents anywhere in the workshop
- Avoid potential damage due to poor placement of supports in the vehicle
- Safe work avoiding damage and injuries.
- Use on vehicles without footrests
- Fast repairs = fewer courtesy vehicles.



# PORTABLE WELD FUME EXTRACTOR

Using Negative Airflow, the Fume Dog Portable Fume Extractor removes fumes and dust particles from the air when welding. The process removes any hazardous gases and airborne particles from your environment, making working conditions safer for everyone. The portability of the Fume Extractor makes this a great addition to any shop as it can be moved easily to maximize it's filtration efficiency.



## Description:

- A 1,200 CFM Portable welding fume extractor with filter cleaning system.
- Fume Arm included
- The Fume Dog can be converted from a ground-mounted portable welding fume extractor to a wall-mounted weld fume collector out of the box.
- Can be converted to downdraft table with an additional accessory..
- The unique Air Stream Filter Cleaner allows for 5-6 times the filter life over traditional reverse pulse systems depending on application.
- Replacement filters are standard size so we can't force you to pay a ludicrous mark up for a filter you can only get from us.
- Seriously, google replacement filters on some of these things. They are priced like they are coated in powdered Rhinoceros horn.
- Steel construction, not plastic.

## Specifications:

**Airflow:** 1200 CFM

**Motor:** 1.5 HP

**Power:** 120v / 1ph

**Dimensions (in):** 40.5" x 26" x 31.5"

**Weight (lbs):** 215 (no arm)

**Arm Diameter (in):** 8"

# PORTACOOL®



## APEX SERIES



### APEX 500 AND 700

#### SPOT COOLING

- Space Optimization
- Digital Louver Control

### APEX 1200, 2000, 4000, AND 6500

#### MEDIUM AREA COOLING

- Extended Cooling Reach
- Whisper Quiet Performance

#### LARGE AREA COOLING

- Simplify Your Space
- Efficient Media Absorbance

						
<b>MODEL NUMBER</b>	PACA05001A1	PACA07001A1	PACA12001A1	PACA20001A1	PACA40001A1	PACA65001A1
<b>OPTIMAL COOLING (Sq. Ft.)</b>	UP TO 500	UP TO 700	UP TO 1200	UP TO 2000	UP TO 4000	UP TO 6500
<b>VELOCITY (Mph)</b>	40	37	25	28	25	24
<b>AIR FLOW REACH (Ft.)</b>	55	60	40	60	50	40
<b>NOISE (dB)</b>	53	53	51	58	62	68
<b>WATER RESERVOIR (Gallons)</b>	13	22	40	45	55	66
<b>PRODUCT WEIGHT (Without Water)</b>	70	88	134	191	220	290
<b>AIRFLOW (CFM'S)</b>	800	1400	4000	6700	13250	22000
<b>AMP'S</b>	2.4	4.0	5.0	8.0	9.0	14.7
<b>DIMENSIONS (In.)</b>	(HEIGHT) 46 (DEPTH) 19.5 (WIDTH) 22	(HEIGHT) 52 (DEPTH) 24 (WIDTH) 27	(HEIGHT) 58 (DEPTH) 26 (WIDTH) 42	(HEIGHT) 68 (DEPTH) 30 (WIDTH) 54	(HEIGHT) 77 (DEPTH) 33 (WIDTH) 63	(HEIGHT) 90 (DEPTH) 39 (WIDTH) 78



# FRAME

# Body Buggy



## CHASSIS ROLLER

### DF-BB104 & DF-BB105

*Rack time is expensive, free up your rack in minutes!*

### APPLICATION

Quick and safe method to transport disabled vehicles off a rack. Vehicle is secured and easily moved around the shop. Roll onto a frame machine or into a paint booth.

### FEATURE & BENEFITS

- **FREE UP RACKS** - Quickly move disabled vehicles off the rack when waiting on parts, inspections, or other delays.
- **HIGHLY MOBILE** - Move the vehicle by hand over speed bumps, dips, or uneven pavement.
- **VERSATILE** - Install on the front or rear of most any vehicle with the wheel assemblies placed on either side of the mounting point.
- **MADE IN THE USA** - Design & manufactured in California for the utmost in quality.

### DESCRIPTION

The patented **Body Buggy** makes the difficult task of moving a disabled vehicle simple and safe. After a simple five minute installation, the unit becomes "part of the vehicle", negating the need to employ any unstable or dangerous lift points. The included spacer kit allows for the use of original fasteners, alleviating the need for any additional fastener inventory. When installed, the vehicle is easily rolled onto a frame rack, into a paint booth or to storage, out of the way of production. The device can be installed on the front or rear of most any vehicle using the cradle or sub-frame mounting points and hardware.



**Kit Includes:**  
Main Beam, Wheel Assemblies, Sliding Lock Collars, Mounting Brackets (2 Pairs of different heights), Hitch Pins & Clips, Fitment Pin Spacer, Storage Crate, and 10 pc Spacer Kit.



### IN ACTION



**ROLLS ANYWHERE:**  
Load vehicles onto the tow truck or anywhere in the shop. Easily roll the vehicle into the paint booth too!



**BECOMES PART OF THE VEHICLE:**  
No need to employ any unstable or dangerous lift points. Mounts to the sub frame or cradle using the original mount points and hardware.

### CONFIGURATIONS





# GUNIWHEEL™

UNIVERSAL VEHICLE MOUNTING SYSTEM



45S (Set of 4)



56 (Set of 4)



80 (Set of 4)



45 (Set of 4)



Gunispare



GUNIX

# MOBILE DOLLY STATION WITH 4 DOLLIES

Keep your Dollies neat and organized. Get the full set of dollies with a nice mobile rack for the dollies and adapters.

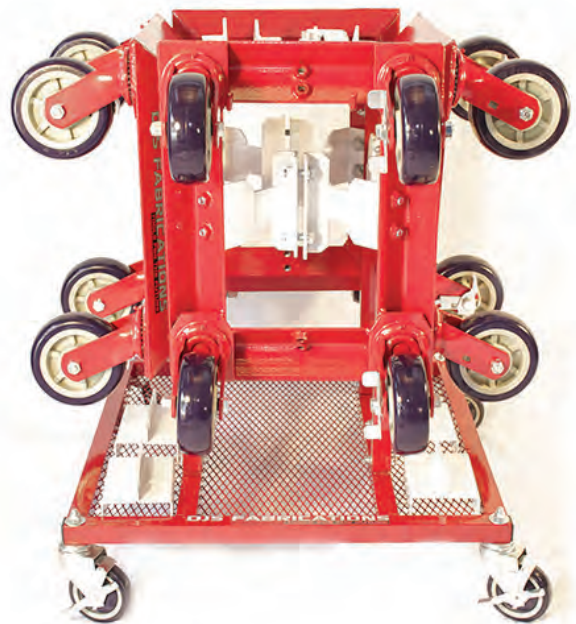
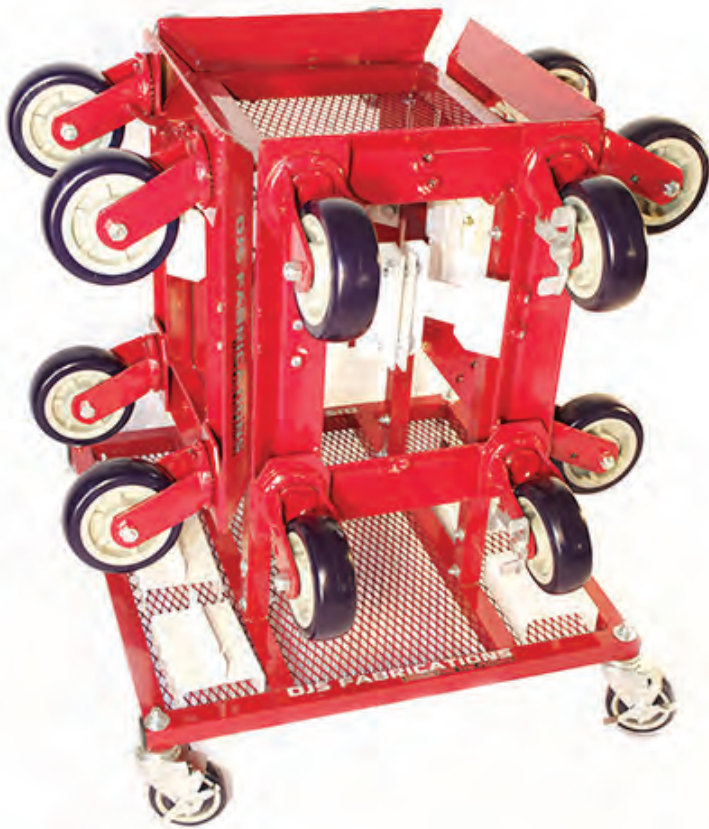

## Set Includes

- Dolly Station
- 4 Universal Dollies
- Each Dolly Includes Pinch Weld and Hub Adapter

## Additional information

- Weight 250 lbs
- Dimensions 40 x 48 x 23 in



**GOLIATH**  
CARTS

**PR1** Parts Cart



- + CONTROL YOUR PARTS WORKFLOW
- + FOLDING SHELVES AND BUMPER STANDS
- + CARTS NEST FOR EASY STORAGE
- + FINE MESH KEEPS SMALL PARTS FROM DISAPPEARING
- + HIGH QUALITY POLYURETHANE WHEELS
- + ASSEMBLES IN LESS THAN 15 MINUTES
- + DIMENSIONS: 46" x 24" x 69"





# GOLIATH CARTS

## GWS Weld Stand

\* For Destructive Weld Testing

Part #GWS-FL1  
Floor Stand



- + AVAILABLE IN FLOOR MOUNT AND MOBILE VERSIONS
- + SUPPORTS ALL TYPES OF WELDS AND POSITIONS
- + DIMENSIONS: 27" L x 18" W x 87" H

Part # GWS-B1  
Mobile Stand



### INCLUDES:

- + SHELF
- + WELD GUN HOLDER
- + WELDING PLIER HOLDER
- + WET/DRY BUCKET
- + WHITE BOARD
- + METAL THICKNESS GAUGE

Coupon  
Holder



*Solutions for Working Smarter™*



# G1 Powered Mobile Work Station

## SPECIFICATIONS

Dimensions (L x W x H)	27" x 21" x 69"
Weight	210 lbs
Printer Compartment Dimensions	9.5" x 21.25" x 19"
Top Clamshell Dimensions	27" x 19.5" x 4.75"

\* Batteries Not Included

## OTHER DIMENSIONS

61.5" To Center of Monitor

Up to 24" Monitor

69" Adjustable Height  
43.5" To Bottom of Keyboard

26" To Bottom of Printer Tray

21"

27"

Locking Upper Box

Slide Out Printer Tray

Large Off-Road Casters



**Power System**  
(Included with ALL Models)  
45 Amp / 3 Phase Charger  
DC to AC Inverter  
Fuses, Power Block, Kill Switch

**Available Versions:**  
Part# G1-A: Base Model  
Part# G1-AT: Fully Loaded (Laptop)  
Part# G1-ATT: Touch Version (Tablet.)  
\*Model G1-AT Shown in Photo



**SIDE SHELF**  
(Optional)  
Part # G1A-SS

**Solutions for Working Smarter™**



**GOLIATH**  
**CARTS**

## TGO-DC2 "ADAS" Mobile Workstation

Part # TGO-DC2-L

- ☞ TRI-SCREEN POWERED MOBILE WORKSTATION
- ☞ PERFECT FOR:  
- "ADAS" CALIBRATION & SCANNING
- ☞ ALL NECESSARY EQUIPMENT CAN BE MOUNTED OR STORED FOR A TRULY MOBILE SOLUTION
- ☞ 4 DAYS OF USE ON A SINGLE CHARGE
- ☞ PROUDLY MADE IN USA 



- + STORES SCANNERS & POWER CONDITIONERS
- + LOCKABLE COMPARTMENTS
- + ADJUSTABLE SCANNER CUBBIES
- + STORAGE FOR CALIBRATION WEIGHTS
- + RUGGED 6" RUN FLAT TIRES
- + SLIDE OUT PRINTER TRAY

# INVENTORY CONTROL UNITS

## CUSTOM BUILD ONLY



When you automate inventory management with Goliath Carts Inventory Control Cabinets, you can replicate best practices across the entire company. This is the most comprehensive and flexible way to implement lean inventory management efficiently and effectively. Gain inventory visualization and security to help reduce overall overhead during the part re-ordering process.

### **Product Features:**

- Gain inventory visibility to improve the re-order process.
- Create employee accountability & control department spending.
- Reduce spend, improve accounting & increase productivity.
- Improve job costing and inventory control/forecasting.
- Dimensions – 24" x 36" x 78"



## Champ Turbo Pro

### Dry Ice blasting machine

Guaranteed quality



- ✓ Gentle cleaning without water and chemicals
- ✓ Simple and strong: powered by compressed air only
- ✓ Clean quickly at low operating costs

#### Technical data:

Operating power	No electricity needed, system powered by compressed air only
Dimensions (L x B x H)	570 x 395 x 480 mm
Net weight	23,5 kg
Hopper capacity	8l
Operating pressure	1/2 Zoll claw clutch
Compr. air Connection	1 - 14 bar (in continuous operation)
Dry ice consumption	30-70 kg (depending on the jet pressure)
Compr. air consumption	800-3500 l/min (depending on blasting pressure and nozzle)
Blasting material	up to 3 mm Dry Ice Pellets, Dry Ice Energy Abrasive Blasting Agent
Volume	60 - 90 dB (A) (depending on jet nozzle and surface)

#### Included equipment:

- ✓ pressure regulator
- ✓ 4 m blasting hose
- ✓ Blasting gun
- ✓ Round Jet nozzle
- ✓ Ice shovel
- ✓ Operating instructions
- ✓ Push bar

#### Additional equipment:

- ✓ Pressure reducer with water cutter
- ✓ Flat Jet nozzle
- ✓ Compressed air hose 15 m with claw clutch
- ✓ Maglite lamp



## Champ Vario

### Dry Ice blasting machine

Guaranteed quality  
Made in Germany

- ✓ Cleaning without water and chemicals - at low operation cost
- ✓ From gentle to powerful - variably adjustable
- ✓ Easy plug & play solution: powered by compressed air only

#### Technical data:

Operating power	Only compressed air, no electricity needed
Dimensions (L x B x H)	520 x 330 x 360 mm
Net weight	13 kg
Dry Ice container	3 Liter
Operating pressure	2 - 10 bar
Compr. air Connection	Safety rapid release coupling, 1/2 Zoll
Dry ice consumption	4 - 38 kg/h – 5,5 bar blasting pressure (depending on set consumption quantity and used pellet size)
Compr. air consumption	300 -1500 l/min (depending on blasting pressure and nozzle)
Blasting material	1,5 - 3mm (0,06 in. - 0,12 in.) Dry Ice Pellets, Dry Ice Energy Abrasive Blasting Agent
Compr. air requirements	clean, oil-free, dry (pressure dew point < 10°C)
Volume	60 - 90 dB (A) (depending on jet nozzle and surface)

#### Included equipment:

- ✓ variable dispensing system of dry ice quantity
- ✓ integrated compressed air regulator and manometer
- ✓ blasting gun
- ✓ 3m blasting hose with detachable working hose (extension option possible)
- ✓ air volume regulation on the gun
- ✓ change-over switch dry ice and compressed air supply
- ✓ round blasting nozzle
- ✓ 7m compressed air hose (incl. safety switch)
- ✓ Compressed air hose connection: European standard hose NW 0,28
- ✓ Special wheels to avoid electrostatic discharge
- ✓ Ice shovel
- ✓ Operating manual

#### Additional equipment:

- ✓ LED lamp Maglite incl. holder
- ✓ Push bar
- ✓ Tank extension to 6 Liter
- ✓ 2 Meter hose Extension
- ✓ Special nozzles for low compressed air supply



# PANEL REPAIR



**CALL US TODAY**

**FOR THE BEST  
EQUIPMENT & SERVICE!**

(855) 999.SCCE

# FLATLINER BUSINESS SYSTEM

## A COMPLETE WORKING STATION FOR ALL DAMAGE REPAIRS

The Flatliner Business System is the key tool—with its excellent selection of bridges and hammers—that repairs damage of any kind to standard vehicles, where all of the work is done entirely from the outside.

### DESCRIPTION

- Smaller repair areas
- Shorter painting times
- Minimizes demontage
- Less demand for spare parts orders
- Saves up to 40% time on auto body repairs





# ALU SLIMLINER

**THE ALU SLIMLINER RANGE (A & B) PROVIDES A COMPREHENSIVE RANGE OF REPAIR SOLUTIONS FOR ALUMINUM PANEL DAMAGES.**

## **Alu Slimliner A (6126)**

A small, complete working station for small to medium collision damages on aluminum applications. Equipped with a bridge system that allows for repair on larger areas.

## **Alu Slimliner B (6107)**

A basic working system for aluminum repair.

### **Alu Slimliner A (6106)**

- 1 Alu Pulling Element Set
- 3 Hammers
- 3 Pulling Bars
- Alumet Spot
- Dentliner
- Individual component
- Slim Trolley
- Speedline Set



### **Alu Slimliner B (6107)**

- Alumet Spot
- Slim Trolley
- Speedline Set



# T-HOTBOX MAGIC WAND SET

The T-Hotbox Magic Wand Set is created especially for hail damage repair. The newly developed Tool Head has a higher power and more focused pulling area. This makes it ideal for the small dents and the finishing process. It comes with a 5-meter working cable and the all-important Extension T, which helps with working on the roofs and rails of the car.

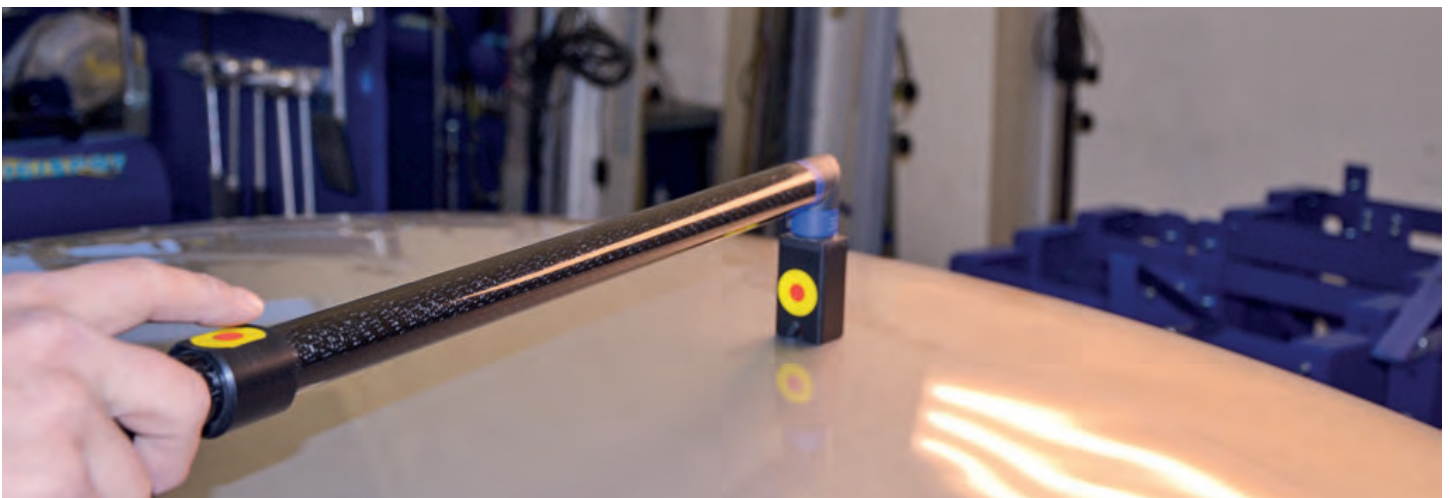

# ALU T-HOTBOX

---

---

## (ALUMINUM)

### THE ALUMINUM REPAIR TOOL FOR SMALL TO MEDIUM DAMAGES

The Alu T-Hotbox repairs small to medium damages on aluminum by utilizing the thermal expansion characteristics of aluminum to its advantage. During the first stage of repair, the Alu T-Hotbox measures the resonance frequency of the tool to match that of the aluminum panel. The Alu T-Hotbox then adjusts itself to optimal frequency to activate the aluminum and allow it to realign itself.



# MULTITOOL

## Aluminum Dent Repair Station

### A Complete Workstation

With all the required tools for aluminum or steel auto body repairs. Specially designed for the repair of aluminum and steel sheet metal panels. Easy to handle, mobile workstation cabinet for dedicated dent repair, tool storage and work bench.

### Features

- Anodized aluminum pulling bar kit (90 cm) with mobile feet and 10x10 cm pivoting bases. The special shape of the feet, with suction cups, will perfectly fit to the car body, including angular surfaces. The kit includes 3 tie-rods and multi-hook gripping heads for a combined or independent dent pulling operation.
- Anodized aluminum pulling system for smaller jobs and a single tie-rod with special heads that can pull either a single or a group of hooks. A circular base accessory for the pulling system (to replace the two feet) is used in the repair of small diameter dents.
- Hammer kit with 4 anodized aluminum hammers:
  1. Round head - 3.2 oz.
  2. Round head - 6.7 oz.
  3. Square head - 6.7 oz.
  4. Mallet - 20.8 oz.
- Heat gun is provided to heat the dented area of the aluminum panel that needs to be repaired.
- Heat shield gel is used to create a barrier to protect the parts of the panel that are not to be heated during the aluminum repair process.
- An angled air die grinder is provided as a dedicated tool to eliminate cross contamination during the aluminum repair. Used to remove the weld studs and/or for other sanding or grinding operations.
- A starter kit of aluminum studs, zinc-plated steel eye-bolts



Workstation front



Workstation back



Aluminum Pulling Bar Kit



Aluminum Pulling System



### Includes MultiSpot M30Pro

115V aluminum capacitor discharge stud welder, complete with grounded stud gun and 2-clamp grounding cables.



### WORKSTATION SPECIFICATIONS

Single phase input	115V 50/60Hz
Supply fuse rating (slow blow)	15 A
Weight	270 lbs.
Dimensions inches	39.4 x 20.5 x 61.4h

# MULTITOOL

## Aluminum Dent Repair Station

### A Complete Workstation

With all the required tools for aluminum or steel auto body repairs. Specially designed for the repair of aluminum and steel sheet metal panels. Easy to handle, mobile workstation cabinet for dedicated dent repair, tool storage and work bench.

### Features

- Anodized aluminum pulling bar kit (90 cm) with mobile feet and 10x10 cm pivoting bases. The special shape of the feet, with suction cups, will perfectly fit to the car body, including angular surfaces. The kit includes 3 tie-rods and multi-hook gripping heads for a combined or independent dent pulling operation.
- Anodized aluminum pulling system for smaller jobs and a single tie-rod with special heads that can pull either a single or a group of hooks. A circular base accessory for the pulling system (to replace the two feet) is used in the repair of small diameter dents.
- Hammer kit with 4 anodized aluminum hammers:
  1. Round head - 3.2 oz.
  2. Round head - 6.7 oz.
  3. Square head - 6.7 oz.
  4. Mallet - 20.8 oz.
- Heat gun is provided to heat the dented area of the aluminum panel that needs to be repaired.
- Heat shield gel is used to create a barrier to protect the parts of the panel that are not to be heated during the aluminum repair process.
- An angled air die grinder is provided as a dedicated tool to eliminate cross contamination during the aluminum repair. Used to remove the weld studs and/or for other sanding or grinding operations.
- A starter kit of aluminum studs, zinc-plated steel eye-bolts



Workstation front



Workstation back



Aluminum Pulling Bar Kit



Aluminum Pulling System



### WORKSTATION SPECIFICATIONS

Single phase input	115V 50/60Hz
Supply fuse rating (slow blow)	15 A
Weight	270 lbs.
Dimensions inches	39.4 x 20.5 x 61.4h

### Includes M35 Drawn Arc Stud Welder

- Automatic gun with 2 Ground Electrodes
- Aluminium Keys consumables box / 1.5 mm
- Lifting rod

**GYSPOT 34.02, with a power of 3500 A, is an ideal tool for dent removal and straightening of steel carbody elements (bonnet, door, roof panel etc.) The product is multifunctional, and effective for many applications. With its low power consumption, it can work on a simple 230V power supply.**

## A MULTIFUNCTIONAL DENT PULLER

### Modes available :

- **Welding of stars and washers** for panel pulling.
- **Wavy wire welding**, ideal for a curved profile (e.g. wheelarch).
- **Contact shrinking**, to work on light impacts and for the highest quality finish.
- Able to use a graphite pencil.
- Welding of steel studs.



## EASY TO USE

- Switch to go to graphite pencil mode.
- **Intuitive**, the control knob enables selection of both the output power and the requested mode.
- **Manual**, the weld is controlled by simply a light press of the gun trigger.

### Cables length

Earth	Gun	Power supply
1.7 m / 50 mm <sup>2</sup>	2 m / 50 mm <sup>2</sup>	2 m

### DELIVERED AS A STANDARD WITH:

- 1 spot inertia hammer (1,1kg) and 1 star holder tip.
- 3 stars
- 1 contact shrinking tip
- 1 earth pad

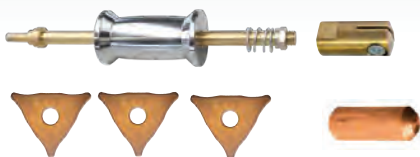

### OPTION:

Trolley  
DENT 600  
Ref: 072831









Trolley  
Spot 800  
Ref: 051331



Spotter Box  
Ref: 053915



	$I_2$ max		$U_2$		$I_{RMS}$				
50/60hz	A		V	A	A	OK	cm	kg	
230V 1~	2600	Manual	5,4	16	1800	OK	20x32x18	14	



# PLASTIC WELDER



**CALL US TODAY**

**FOR THE BEST  
EQUIPMENT & SERVICE!**

(855) 999.SCCE



# WELDERS

## PROFESSIONAL PLASTIC WELDERS



### 8303 Nitro-Fuzer® Touch

The 8303 Nitro-Fuzer® Touch features a large touchscreen that simplifies welding with easy control functions, including temperature and airflow. Pre-programmed with over 20 different plastic types and their recommended settings. Selecting the plastic type automatically adjusts the temperature and airflow. Features real-time airflow temperature monitoring. Includes an integrated airless plastic welder and a nitrogen generator for continuous nitrogen without the hassle of changing a nitrogen bottle. Fully assembled on a heavy-duty cart.



### 8302 Nitro-Fuzer® Touch

The 8302 Nitro-Fuzer® Touch features a large touchscreen that simplifies welding with easy control functions, including temperature and airflow. Pre-programmed with over 20 different plastic types and their recommended settings. Selecting the plastic type automatically adjusts the temperature and airflow. Features real-time airflow temperature monitoring. Includes an integrated airless plastic welder. The LiDAR torch sensor automatically switches air source to nitrogen for welding. Requires nitrogen bottle (not included). Includes a nitrogen bottle regulator. Fully assembled on a heavy-duty cart.



### 8203 Nitro-Fuzer®

The 8203 Nitro-Fuzer® features dual digital encoders for precisely and repeatably controlling the nitrogen temperature. Features a precision flow valve for nitrogen flow control. The analog flow gauge allows for repeatable performance. Includes an integrated airless plastic welder for smoothing welds and repairing thermoset polyurethane (PUR). Includes a nitrogen generator for continuous nitrogen without the hassle of changing a nitrogen bottle. Fully assembled on a heavy-duty cart.



### 8202 Nitro-Fuzer®

The 8202 Nitro-Fuzer® features dual digital encoders for precisely and repeatably controlling the nitrogen temperature. Features a precision flow valve for nitrogen flow control. The analog flow gauge allows for repeatable performance. Includes an integrated airless plastic welder for smoothing welds and repairing thermoset polyurethane (PUR). The nitrogen torch holster switch provides automatic switching between air and nitrogen. Requires nitrogen bottle (not included). Includes a nitrogen bottle regulator. Fully assembled on a heavy-duty cart.



Polyvance Nitro-Fuzer welders are available through Polyvance's Nitro-Fuzer Distributor network. Contact Polyvance to receive the information for the Nitro-Fuzer Distributor in your area.





# 8203 NITRO-FUZER®

## NITROGEN PLASTIC WELDER & ACCESSORY KIT

### SUPERIOR PLASTIC WELDING AND REPAIR ACCESSORIES ALL IN ONE

Are you looking to take your plastic repair capabilities to the next level? Look no further than the Polyvance Nitro-Fuzer Nitrogen Plastic Welder and Accessories Kit – the ultimate NitroFuzer plastic welding system. This comprehensive all-inclusive kit is designed to enhance your plastic welding experience and help you achieve flawless, durable repairs.



8203 NITRO-FUZER® NITROGEN PLASTIC WELDER ACCESSORY KIT		
	8203	NITROFUZER, N2 GENERATOR WITH CART
	1001-4	ECO-PREP PLASTIC CLEANER (ZERO VOC)
	6204	HOT SPOT CORDLESS HOT STAPLER
	6149	SENSOR HOLE CUTTING KIT
	6480	2-INCH WIDE MAGNETIC TAPE SPOOL
	6225	TAB MAGIC MOLDING PUTTY
	6119	DENT DRIVER KIT
	6074	NITRO-FUZER ACCESSORY SHELF
	6485	ALUMINUM TAPE- LARGE ROLL- 2" WIDE X 180'
	6450	BUMPER BAG PLUS
	6142	SHIM JIM TAB SEPARATOR TOOL
	6077	BUMPER MATE 3
	6146	BUMPER PLIERS KIT



ACCESSORY KIT



HOT SPOT CORDLESS HOT STAPLER

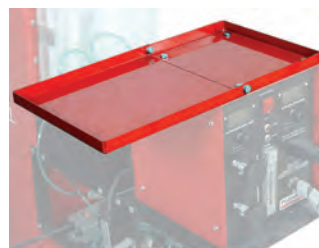

NITRO-FUZER ACCESSORY SHELF



SENSOR HOLE CUTTING KIT

# Plastic Fusion

## Plastic Fusion Pro Station (10400)



- Plastic Fusion Pro Unit
- Integrated Tacker
- 3 Fusion Modes
- Plastic Vice
- Two Speed Grinder

- Flat Welding Strips
- Tacks
- Plastic Dent Wheel Set
- Nitrogen & External air connection

## Complete Plastic Repair Station



## Optional Add Ons



- Plastic Dent Wheel Set (10554)



- Plastic Welding Set (10030)



- Nitrogen Bottle Holder (10415)

## Plastic Fusion Pro Slim (10404)



**Plastic Fusion  
Business Station** (10450)



- Plastic Fusion Business Unit
- Plastic Vice
- Flat Welding Strips
- Plastic Dent Wheels
- Integrated Tacker
- Tacks
- Two Speed Grinder

**Plastic Fusion  
Business Slim** (10454)



**Plastic Fusion  
Eco Station** (10470)



- Plastic Fusion Eco Unit
- Plastic Vice
- Two Speed Grinder
- Flat Welding Strips

**Plastic Fusion  
Eco Slim** (10474)





# THERMODRY TECHNOLOGY



**CALL US TODAY**

**FOR THE BEST  
EQUIPMENT & SERVICE!**

(855) 999.SCCE

# The Thermodyr Technology system is based on 3 main functions:

## AIR HEATING AND THERMOREGULATION (TD3 PRO, TD1 PRO)

Compressed air used in paint booths is generally influenced by low temperatures in the winter and by high relative humidity the summer. Even with adequate booth heating or, in the summer, cooling dryers, temperature of the air entering the gun stock has a hard time reaching 75 °F. It should also be taken into account that air expansion causes temperature to drop an addition 50 °F - 54 °F, lowering paint atomization air to a temperature under 50 °F. With relative humidity under room temperature "dew point", a micro-mist that mixes with the paint may be generated. Therefore, the ideal 75 °F conditions indicated by paint manufacturers for satisfactory results are not met with consequent loss of brilliancy, orange peel effects and poor paint distribution.

**The Walcom® Thermodyr Technology system heats and maintains the set air temperature regardless of climate/room conditions.** The operator can set temperature from 68 °F - 122 °F for the painting phase and up to 158 °F for the drying phase. The PID retroaction system (proportional-integrated-derived) and instant regulation of the heating power at SCR (wave cut) keeps the temperature set by the operator constant. The IPH heating system has the same heating element features as the equipment, thus providing both tube heating and internal temperature control, keeping it constant during the entire paint cycle.

## AIR FILTRATION (TD3 PRO)

This fully removes solid and gaseous impurities from the compressed air output in 4 phases:

- separation from water with automatic drain
- separation of any oil traces with manual drain
- elimination of residual humidity with silica gel and output dew-point conditioning at values -30°cdp
- elimination of all impurity residue and the creation of breathable air with a carbon active filter.

## AUTOMATIC DEHUMIDIFYING MASS REGENERATION (TD3 PRO)

SRS regenerates silica gel in just 4 hours with the push of a button. This is achieved by reverting flow of heated air to temperatures suited to regenerate the dehumidifying mass. Equipment comes with a timer to automatically turn off the regenerative system after 4 hours and make it ready for operator's use

## TD3 PRO

- 2 painters
- precise thermocontrol
- full filtration and drying
- silica regeneration



## TD1 PRO

- 2 painters
- precise thermocontrol



IPH: 36 ft. - 50 ft. - 74 ft. galvanized rubber I Ox 15 air tube, anti-static finish, heated by an internal 1200 W resistance and complete with J thermocouple for temperature regulation. It rapidly reaches the set temperature and efficiently maintains it.

The Walcom ThermoDry systems thermoregulated air allows you to heat materials at the point of atomization within your spray gun nozzle free of gaseous impurities and humidity.

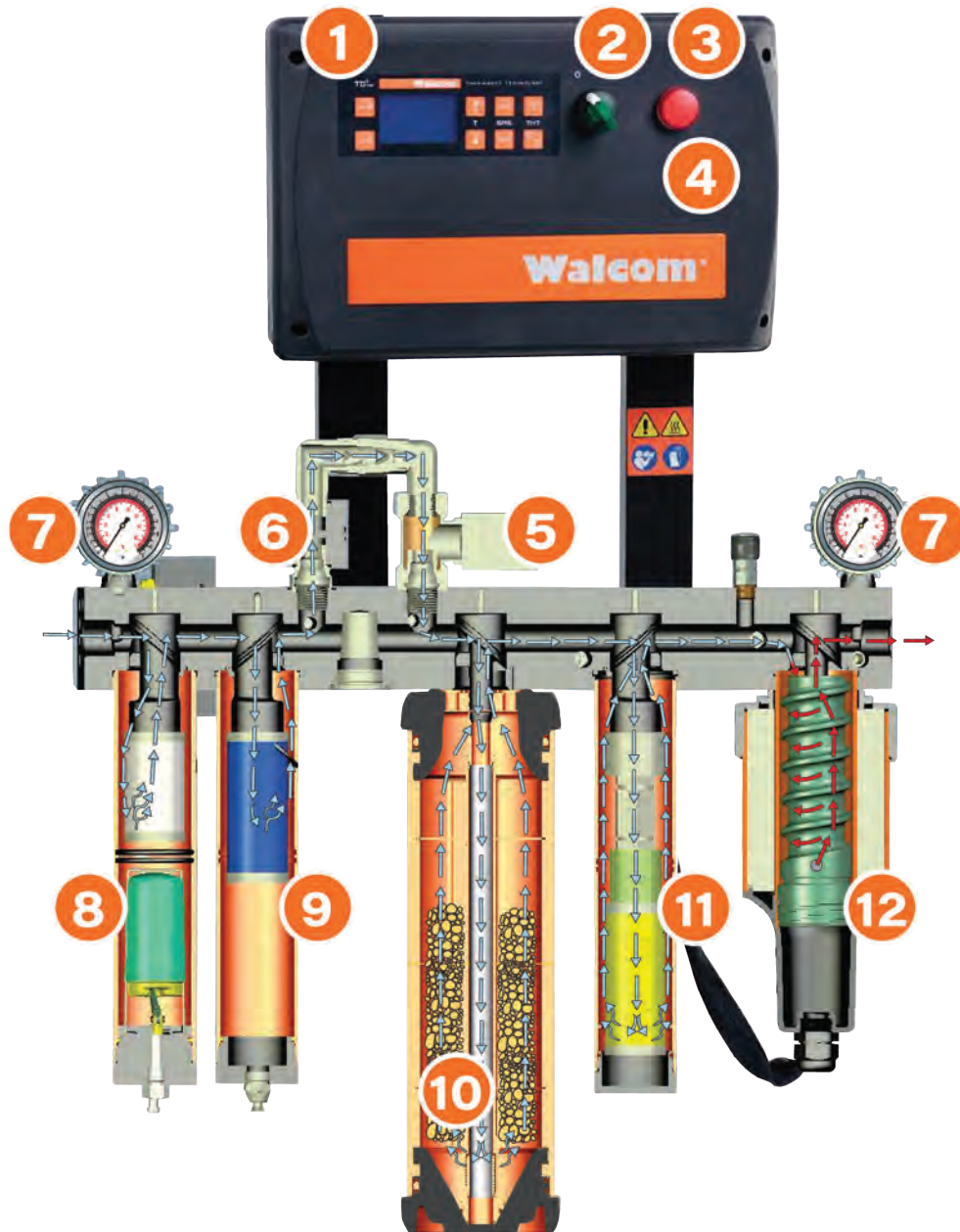

**1** LCD Control & Display

**2** On/Off Switch

**3** Fault Indicator

**4** PID Panel

**5** Solenoid Valve SRS

**6** Pressure Regulator

**7** Pressure Gauge

**8** Water Filter

**9** Oil Filter

**10** Silica Dehumidifier

**11** Active Carbon Filter

**12** Heater Element

## SYSTEM BENEFITS

Reduces drying time by 25% to 40% for waterborne and solvent based paints

Saves up to 15% in materials due to higher transfer efficiency and maximum coverage

Greatly cuts down on overspray due to superior atomization, and as a result extends spraybooth filters lifecycle

Reduces cycle times and operating temperatures of your existing spraybooth, saving time and energy

Considerably less time spent on buffing as a result of a clean paintwork

Increases overall body shop efficiency by allowing more paint cycles a day/week

### NEW SOFTWARE

The I.II version efficiently manages TD operations, controlling any system faults.



### THT

New high performance hose with 1200 W power



### DOUBLED AIR FLOW

The 43 cfm air flow lets you use 2 spray guns simultaneously.



### DRAIN SYSTEM

Automatic for water with safety rod for any clogs; manual for oil





# AC EQUIPMENT



**CALL US TODAY**

**FOR THE BEST  
EQUIPMENT & SERVICE!**

(855) 999.SCCE



# R3AC80

**DualGas**  
RECHARGING STATION

**DUAL GAS READY! RECOVER, RECYCLE AND RECHARGE BOTH R134A & R1234YF REFRIGERANT GAS WITH ONE MACHINE.**



## INTUITIVE, FAST OPERATION

- Interface, software, and connected sensors work fast and seamlessly.
- All functions are on main page.
- Complete operations in just a few steps.
- Quickly identifies the vehicle by entering keywords.



## GAME CHANGING AUTOMATION

- Identifies the incoming gas and purges automatically.
- Gases are identified with a purity check, a 3-minute purge when switching gases with no user input or action.

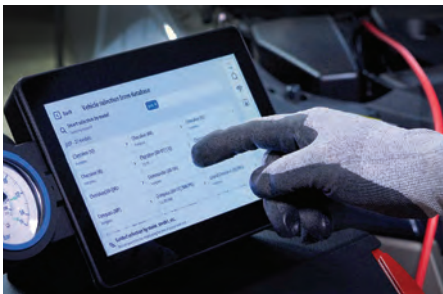

## INDUSTRIAL TOUCHSCREEN INTERFACE

- 10-inch multi-touch color screen displays a clear view of data.
- Works with leather or industrial nitrile gloves.

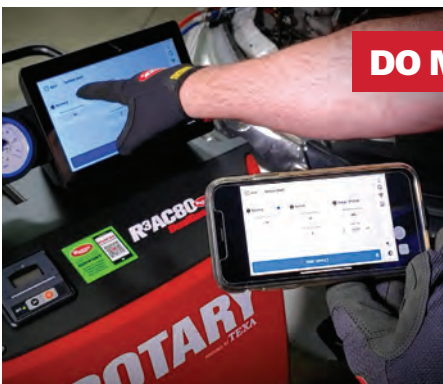

## DO MORE WITH THE APP

## WIFI READY

- WIFI enabled and designed for automatic or customized use.
- Software includes access to real-time vehicle data and software updates.\*
- Interact and monitor the machine from anywhere in the shop with our DIGITIQ app.



## EASY MOVEMENT

- Lockable 360 degree movement casters provide easy mobility.
- Solid, robust wheels will never go flat.

**THE A/C MACHINE THAT DOES IT ALL UP TO 50% FASTER!**



MODEL SHOWN:  
**R3AC80-AYF**  
**DUAL GAS SYSTEM**  
SHOWN WITH OPTIONAL  
THERMAL PRINTER.

**WATCH AND LEARN!**  
Scan code to watch product demo videos.



\*Contact your Rotary representative for details.

# OEM-trusted, shop-tested R-1234yf recovery machines

## Standard on all Robinair R-1234yf machines:

- > 1.5 CFM dual-stage vacuum pump
- > 22-lb DOT internal tanks (30-lb DOT on AC1234-9)
- > 9' SAE J2886 hoses (8' SAE J2888 on AC1234-6)
- > 330-lb (150kg) spin-on filter, P/N 34724
- > Integrated cord wrap
- > Unmatched minimum 98.5% refrigerant recovery
- > Charging accuract to within +/- 0.5 oz



Features	AC1234-6	AC1234-4	AC1234-9
WiFi capable	No	Yes, requires 80211TMP or 80211VCI master kit	Yes, enabled from the factory
Bluetooth capable	No	Yes, requires 80211TMP or 80211VCI master kit	Yes, enabled from the factory
Operating system	Windows CE	Robinair proprietary OS	Android 8.1 Oreo
Free WiFi software updates	N/A - not WiFi capable	Yes, requires 80211TMP or 80211VCI master kit	Yes, enabled from the factory
Fully-Automatic Function	Yes	Yes	Yes
Integrated refrigerant identifier (meets SAE J2927)	Yes	Yes	Yes
Automatic Refrigerant Refill: Maintains a user-selectable amount of refrigerant in an internal vessel and signals when it's time to change supply tank, no monitoring required	Yes	Yes	Yes
A/C System Refrigerant Flush (Flushing adapters not included)	Yes	Yes	Yes
Vacuum Feature: Defaults to 15 mins, programmable up to 99 mins. "Remaining time" is displayed.	Yes	Yes	Yes
Automatic Oil Drain: Shows amount of oil to replace	Yes	Yes	Yes
Automatic air purge - removes potential of air accumulating in the internal tank	Yes	Yes	Yes
Vacuum Leak Test and Monitoring	Yes	Yes	Yes
Display: Multilingual.	5.7" 960x240 QVGA color LCD	Yes, 4.3" 480x272 QVGA Color LCD	Yes, 10.5" hi-res touch screen
Refrigerant charging	High, low or both sides	High, low or both sides	High, low or both sides
Refrigerant & Oil System Capacity Database for North American market vehicles	Optional, 34414-B	Optional, 34413-D	Optional, 34002
Save, print and store before and after service data	Yes, printer included	Yes, optional printer 30038	Yes; Mopria Print Service wireless printing and PDF export option
Refrigerant Management System: Displays refrigerant use and monitors remaining filter life. Prompts appear when 1/3 of filter life remains.	Yes	Yes	Yes
Electric Vehicle: Capable of servicing high voltage electric compressor A/C systems.	Yes	Yes	Yes
Visual & Audible Alarm / Notifications	Yes	Yes	Yes

Specifications	AC1234-6	AC1234-4	AC1234-9
Operating voltage	103 - 127V, 60 Hz AC	115 VAC, 60 Hz	125 VAC, 60 Hz
Pressure gauges	100mm, EN-837-1	100mm, EN-837-1	Digital display
Keyboard	Alpha-numeric with service function keys	Alpha-numeric with service function keys	Touchscreen virtual keyboard
Compressor	1/3 hp hermetically sealed	1/3 hp hermetically sealed	3/8 hp, pressure-protected, oiled, hermetically sealed
SAE compliance for R-1234yf	Yes, J2843, J2927 certified	Yes, J2843, J2927 certified	Yes, J2843, J2927 certified

# The right machine is always Robinair

## Standard on Robinair R-134a machines:

- > 1.5 CFM dual-stage vacuum pump (single-stage on 34288NI)
- > 30-lb DOT internal tanks (22-lb DOT on 34288NI)
- > 9' SAE J2886 hoses (9' SAE J2196 on 34288NI)
- > 150-lb (68kg) spin-on filter, P/N 34724
- > Integrated cord wrap
- > Unmatched minimum 98.5% refrigerant recovery
- > Charging accurat to within +/- 0.5 oz



Features	34288NI	34788NI	34788NI-H	34988NI	34998
Fully-Automatic Function	Semi-automatic, manual valves	Yes	Yes	Yes	Yes
Automatic Dye Inject: 1/4-oz during recharge, user-selectable	—	—	—	Yes	Yes
Automatic Oil Drain: Shows amount of oil to replace	Yes	Yes	Yes	Yes	Yes
Automatic Oil Inject, user-programmable	18480 or 18490 syringe required	Yes*	18480 or 18490 syringe required	Yes*	Yes*
Refrigerant & Oil System Capacity Database for North American market vehicles	Optional, 34412-E	Optional, 34412-E	Optional, 34412-E	Optional, 34412-E	Optional, 34001
A/C System Refrigerant Flush (Flushing adapters not included)	—	Yes	Yes	Yes	Yes
Save, print and store before and after service data	No save, optional printer 30038	Yes, optional printer 30038	Yes, optional printer 30038	Yes, printer included	Yes; Mopria Print Service wireless printing
Visual & Audible Alarm / Notifications	—	Yes	Yes	Yes	Yes
Vacuum Leak Test and Monitoring	—	Yes	Yes	Yes	Yes
Automatic Air Purge: Eliminates system-damaging air without monitoring gauges or opening valves.	Yes	Yes	Yes	Yes	Yes
Automatic Refrigerant Refill: Maintains a user-selectable amount of refrigerant in an internal vessel and signals when it's time to change supply tank, no monitoring required	—	Yes	Yes	Yes	Yes
Vacuum Feature: Defaults to 15 mins, programmable up to 99 mins. "Remaining time" is displayed.	Yes	Yes	Yes	Yes	Yes
WiFi / Bluetooth capable	Yes, requires 80211TMP or 80211VCI master kit	Yes, requires 80211TMP or 80211VCI master kit	Yes, requires 80211TMP or 80211VCI master kit	Yes, requires 80211TMP or 80211VCI master kit	WiFi, Bluetooth enabled from the factory
Display: Multilingual.	Yes, 4.3" 480x272 QVGA Color LCD	Yes, 4.3" 480x272 QVGA Color LCD	Yes, 4.3" 480x272 QVGA Color LCD	Yes, 7" graphical LCD	Yes, 10.5" hi-res touch screen
Refrigerant Charging:	Low side only	High, low or both sides	High, low or both sides	High, low or both sides	High, low or both sides
Refrigerant Management System: Displays refrigerant use & monitors remaining filter life. Prompts appear when 1/3 of filter life remains.	Yes	Yes	Yes	Yes	Yes
Electric Vehicle: Capable of servicing high voltage electric compressor A/C systems.	—	—	Yes	—	—

\*34788NI uses one oil bottle; 34988NI and 34998 include two oil bottles and one UV dye bottle

Specifications	34288NI	34788NI	34788NI-H	34988NI	34998
Operating voltage	115V, 60 Hz	125 VAC, 60 Hz	125 VAC, 60 Hz	125 VAC, 60 Hz	125 VAC, 60 Hz
Pressure gauges	80mm	100mm, EN-837-1	100mm, EN-837-1	100mm, EN-837-1	Digital display
Keyboard	Alpha-numeric with service function keys	Alpha-numeric with service function keys	Alpha-numeric with service function keys	Alpha-numeric with service function keys	Touchscreen virtual keyboard
Compressor	1/3 hp hermetic	3/8 hp, pressure-protected, oiled, hermetically sealed	3/8 hp, pressure-protected, oiled, hermetically sealed	3/8 hp, pressure-protected, oiled, hermetically sealed	3/8 hp, pressure-protected, oiled, hermetically sealed
SAE compliance for R-134a	Yes, J2788 certified	Yes, J2788 certified	Yes, J2788H certified	Yes, J2788 certified	Yes, J2788 certified



MX1234 (R-1234yf)

### Highlighted Features

1. Touch-screen LCD Display
2. High-side Gauge (Analog)
3. Low-side Gauge (Analog)
4. Storage for Small Tools or Fittings
5. 4" Total Locking Swivel Casters
6. 10" Foam-Filled Wheels

### FEATURES

- 7" Color touch screen control panel to allow quick access to all functions from the main screen
- Bluetooth/Wireless Adapters #TAC100 (Optional) that enable complete pre- and post-service health checks of the system
- Refrigerant Management System monitors filter life and refrigerant usage
- Two product configurations for:
  - R-134a
  - R-1234yf
- Supports multiple languages/UOM
- Hose management built into the handle assembly
- Includes vehicle data base for oil and refrigerant charging capacities
- Warranty: 1-year labor / 2-year parts / 3-year compressor

### 12.67cc Oil-less Compressor

- Designed and built by CPS for high capacity commercial applications
- Eliminates failure issues due to improper oil filling of traditional compressors

### Motor-Controlled Ball Valves

- Opens wider for greater flow
- Resistant to clogging of debris or sealants
- Faster recovery and tank fill

### SPECIFICATIONS

- Thermal Printer (Optional)
- Wi-Fi printer capable
- Heater Blanket #CCXHB (Optional). Reduces recharge time in colder weather
- 30Lb Recovery tank
- Recovery rate = Up to 1 lb/min
- 2 CFM vacuum pump
- 3.5" gauges
- 10' power cord
- 10' hoses
- 115v, 850 W

### 7" TOUCH SCREEN DISPLAY

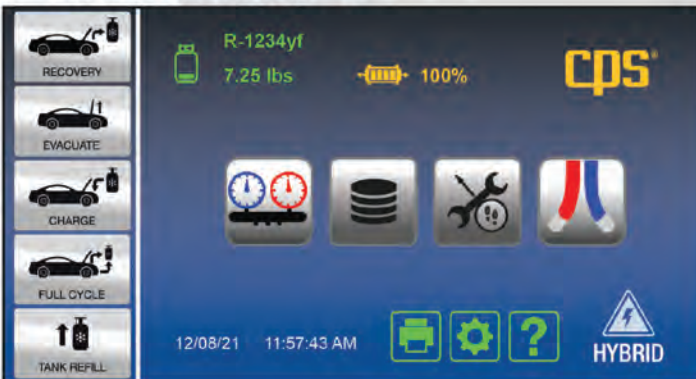

Home Screen features 5 Selectable Functions along with touch keys and information icons.



Refrigerant Charging Screen with interactive touch pad and port selection, database, and change UOM touch keys.

Part Number	Refrigerant	Dimensions				UPC	HTC
		H (in)	W (in)	D (in)	Weight (lbs)		
MX134	R134	44	23	28	208	750377120299	8415.83.0090
MX1234	R1234	44	23	28	208	750377120305	8415.83.0090



**MX3030**  
(R-134a/R-1234yf)

### Highlighted Features

1. Touch-screen LCD Display
2. High-side Gauge (Analog)
3. Low-side Gauge (Analog)
4. Storage for Small Tools or Fittings
5. 4" Total Locking Swivel Casters
6. 10" Foam-Filled Wheels

### 7" TOUCH SCREEN DISPLAY

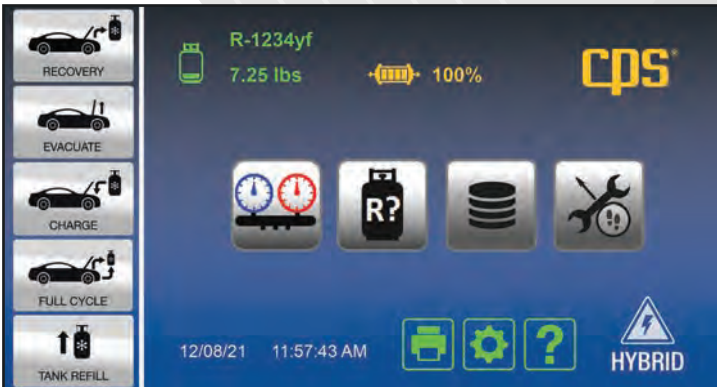

MX3030 Home Screen features 5 Selectable Functions along with touch keys and information icons.

### FEATURES

- 7" Color touch screen control panel to allow quick access to all functions from the main screen
- Bluetooth/Wireless Adapters #TACI100 (Optional) that enable complete pre- and post-service health checks of the system
- Refrigerant Management System monitors filter life and refrigerant usage
- One machine covers both R-134a and R-1234yf
- Includes Refrigerant ID
- Conversion between refrigerants can be done in approximately 10 minutes
- Supports multiple languages/UOM
- Hose management built into the handle assembly
- Includes vehicle database for oil and refrigerant charging capacities
- Warranty: 1-year labor / 2-year parts / 3-year compressor

### 12.67cc (2/3 hp) Oilless Compressor

- Designed and built by CPS for high capacity commercial applications
- Eliminates failure issues due to improper oil filling of traditional compressors

### Motor-Controlled Ball Valves

- Opens wider for greater flow
- Resistant to clogging of debris or sealants
- Faster recovery and tank fill

### SPECIFICATIONS

- Thermal Printer (Optional)
- Wi-Fi printer capable
- Heater Blanket #CCXHB (Optional). Reduces recharge time in colder weather
- Dual 30Lb tanks
- Recovery rate = Up to 1 lb/min
- 2 CFM vacuum pump
- 3.5" gauges
- 10' power cord
- 10' hoses
- 115v, 850 W



Refrigerant Change Screen: select Refrigerant Change key (highlighted) and follow onscreen instructions to change refrigerant.

Part Number	Certification	Refrigerant	Dimensions				UPC	HTC
			H (in)	W (in)	D (in)	Weight (lbs)		
MX3030	SAE J3030	R134a/R1234yf	44	23	28	233	750377120312	8415.83.0090



# MAXXIMIZED PRODUCTIVITY AND VALUE BUILT INTO ONE MACHINE

Efficiently Recover, Recycle, and Recharge your Customer's Automotive A/C Systems with a unit that can serve ALL refrigerant types. If you're considering 1234yf units, get the best of both worlds with the MX3030!

MX3030 (R-134a/R-1234yf)

## MAXXAIR™ ADVANTAGES

**Compatible with Electric and Traditional Engine-Driven Compressors**

**Heavy Duty Construction**

- Durable welded steel frame
- Designed to withstand the harshest shop environments

**10" Foam Filled Tires**

- No flat, maintenance-free tires
- Larger tire diameter for greater mobility over shop floor obstacles

**Patented Motor-Controlled Ball Valves**

- Resists sticking and clogging
- Larger opening for increased flow

**Patented Oilless Compressor**

- Designed for high capacity applications
- Increased service life over competitor oiled compressors
- Unique design enables recovery of liquid refrigerant

**Removable Tank for Transport**

- Eliminates the need for scale locks
- Includes two (2) 30Lb tanks and hose sets

**Providing the Industry's Best –  
MAXXAIR™ Warranty (1-2-3)**

**SAE J3030 Certification**



**YOUR SINGLE MACHINE OPTION!**



# LIFTS



**CALL US TODAY**

**FOR THE BEST  
EQUIPMENT & SERVICE!**

(855) 999.SCCE



**ENGINEERED TO PERFORM. BUILT TO LAST.**

Reliable lift systems for independent repair shops, car dealerships, bodyshops, home enthusiasts, and heavy-duty truck facilities.



# I-10

## LIGHT DUTY TWO POST LIFT

10,000 lbs. Capacity

### FEATURES:

Symmetrical column design  
 Spot-Rite™ 3-stage front arm design  
 - spot vehicles asymmetrically or symmetrically

- Top mounted Direct-Pull lifting technology
- Cylinder rod concealed inside carriage
- Adjustable width options
- Single point lock release
- Powder coated finish
- Includes adapter storage bracket
- ALI Certified



FWD I10N400MBL

**INCLUDES LOW-PROFILE THREADED ADAPTERS AND (4 each) ADAPTER EXTENSIONS AT 3.5" and 5"**



### Spot-Rite™ 3-Stage Front Arm Design

accommodates vehicle spotting both symmetrically and asymmetrically. Position the vehicle doors in front of or behind the lift columns to prevent door damage and allow easy technician access!

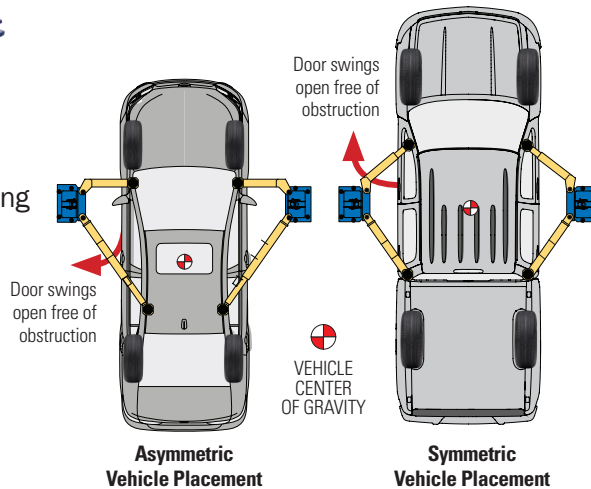

SPECIFICATIONS	I10N400MBL/RD*
Capacity	10,000 lbs. (4535kg)
Maximum rise	76-1/4" (1937mm) w/5" extension
Overall Height	143" (3632mm)
Overall Width	131" or optional 137" (3327mm/4380mm)
Drive through clearance	99" (2515mm) or optional 105" (2667mm)
Overhead switch height	137-5/8" (3496mm)
Front reach (Min/Max)	23" / 44-3/8" (584mm/1127mm)
Rear reach (Min/Max)	36" / 58" (914mm/1473mm)
Min/Max adapter height	3-3/4" (95mm) w/o adapter extension 8-3/4" (222mm) w/ 5" adapter extension
Width inside column	109" or optional 115" (2769mm/2921mm)
Voltage/ Amps	208V/230V, 17 amps
Motor/Phase	1ph/2HP/60Hz
Ceiling height required	144" (3658mm)



\*Lifts available in blue and red  
 Specifications subject to change without notice or liability.





**ENGINEERED TO PERFORM. BUILT TO LAST.**

Reliable lift systems for independent repair shops, car dealerships, bodyshops, home enthusiasts, and heavy-duty truck facilities.

**Double your parking space instantly  
- perfect for the home enthusiast**

# EFP8

**LIGHT DUTY FOUR POST LIFT**  
8,000 lbs. Capacity



**FEATURES:**

Commercial grade lifts. Perfect for home use

- Exclusive adjustable lock ladder system
- Multi-position locks allow runways to be level at any lock position
- Single point lock release
- Powder coat finish
- Lifts available in black only

**INCLUDES:**

- Steel approach ramps
- Wheel caster kit
- Jack tray
- Drip trays

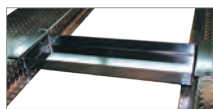

**SPECIFICATIONS EFP8P000M**

Capacity	8,000 lbs. (3628kg)
Rise	72" (1828mm)
Overall length with approach ramps	207-1/2" (5270mm)
Overall length without approach ramps	175-1/2" (4457mm)
Overall width without motor	103-1/2" (2628mm)
Approach ramp length	32" (812mm)
Runway width	18-1/2" (469mm)
Runway length	169-1/2" (4305mm)
Runway height	4-1/2" (114mm)
Height of columns	81-1/2" (2070mm)
Clearance between columns	94" (2387mm)
Clearance between runways	38" (965mm)
Outside runway to outside runway	74" (1879mm)
Clearance under runway	68" (1727mm)
Motor	115VAC, 1HP





# EFP9

LIGHT DUTY FOUR POST LIFT  
9,000 lbs. CAPACITY

**Includes 20" wide runways for wider vehicles!**



SHOWN:  
EFP9P000MBK



**84" MAXIMUM RISE**



**79 1/4" CLEARANCE UNDER RUNWAYS**

**Commercial grade lift - perfect for the shop or home use.**

**Double your parking space instantly!**

### FEATURES:

- Exclusive Adjustable Lock Ladder Leveling System to enable level runways at all lock heights - even on uneven floors
- Multiple height lock positions to work at a comfortable height or store a vehicle at a height that works with your ceiling height
- Operate the lift from one column with the Power Unit and single point lock release
- Power unit and lock release can be mounted to any column that works best for your garage
- Steel approach ramps • Durable black powder coat finish
- Powered with standard 115V plug included

### INCLUDES:

- Wheel Caster Kit
- Jack Tray
- Drip Trays



### OPTIONAL ACCESSORIES:

- **RRJ45** / 4,500 lbs. capacity hydraulic hand pump Rolling Jack



- **90° power unit bracket** moves power unit to the front of column for additional space.



### CAN FOUR POST LIFTS FIT IN MY SHOP OR GARAGE?

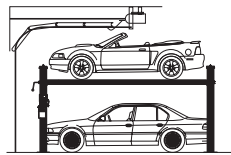

To determine the space requirements needed for your four-post lift, scan this code or go to [www.forwardlift.com](http://www.forwardlift.com) and click on **CEILING HEIGHT CALCULATOR**.

### ALI GOLD CERTIFIED

Forward Lift EFP9 meets the highest industry safety and performance standards. Your assurance of certification is the gold ALI/ETL certified label.



### SPECIFICATIONS EFP9P000MBK

Capacity	9,000 lbs.
Maximum Rise	84"
Clearance Under Runway	79 1/4"
Overall Length with Approach Ramps	18' 9 1/2"
Overall Length without Approach Ramps	16' 1 1/8"
Overall Width with Motor	11' 1/2"
Overall Width without Motor	10' 1 1/2"
Approach Ramp Length	37"
Runway Width	20"
Runway Length	184 1/2"
Runway Height	4 3/4"
Drive Thru Width	97"
Column Height	8' 1"
Clearance Between Columns	109 1/2"
Clearance Between Runways	39"
Outside Runway to Outside Runway	79"
Motor	115VAC, 1HP





LIFTING TABLE SHOWN AT LOWERED HEIGHT

## 5 AIR SYSTEM CONTROLS

Standard air over hydraulic pump is easier to operate and far more accessible than manual, electric or battery pumps. Manual pumps are slow and require effort. Electric is less available in bays. Batteries require charging and maintenance lessening their dependability.



**Air connection** is conveniently placed for easy access



**Air lock release** is operated by a simple toggle switch

## FOOT PEDAL CONTROLS RAISE AND LOWER LIFT



Push top of foot pedal to lower table



Push rear of foot pedal to raise table

## 6 FIXTURING HOLES ON LIFT TOP SURFACE

Threaded 10mm holes on tabletop for attaching mounts and brackets allow for a broader array of service functions.

## 7 MULTI-DIRECTIONAL CASTERS

Large 360° casters with rotational locks provide easier movement and directional control.

- Locking a single caster enables easier movement versus swivel casters on only one end of lift.
- When moving the lift table, the casters may be locked directionally by pressing the blue foot tab downward.
- For ease of fore/aft movement only lock one front caster.
- Lock the lift table into desired position by pressing only the caster locking foot tab.



**Directional locking tab**

**Caster locking tab**

locks the entire caster on the surface holding the wheel in the locked position

Optional 8" casters are available for extra height and clearance.\*

SPECIFICATIONS LT33A000YEBK	STANDARD 6" CASTERS	OPTIONAL 8" CASTERS*
Lift Table Capacity	3,300 lbs.	
Maximum Rise Height	67 3/8"	69 3/8"
Collapsed Height	26 1/4"	28 1/4"
Overall Width	36 1/4"	
Overall Length	97 3/8"	
Deck Width	31 7/8"	
Deck Length	Closed: 73 5/8" Open: 81 5/8"	
First Locking Positions**	32"	34"
Air Requirements	90-120 PSI 6.2-8.3 bar	
Clearance	4 3/4"	6 3/4"
Overall Weight	1,300 lbs.	

\* 8" caster part #LT33A-5300E / Quantity of 4 required

\*\* 9 locking positions. Standard color is black.



# SPO10 SERIES TWO POST LIFTS

10,000 lbs. CAPACITY / SYMMETRIC LIFTS

## Trust the industry standard symmetrical two post lift.

For over 30 years, Rotary Lift has built quality into every two-post we've designed. With industry-leading features, the SPO10 delivers everything your shop needs.

### Choose your:

- Arm configuration and adapter type
- Lift height • Power option and accessories

### SYMMETRIC LIFT SPECIFICATIONS

#### \*WITH SHOCKWAVE

Overall Height: 11' 8-1/2" / 12' 4-1/2"

Overall Width: 11' 5-5/8"

Drive-thru: 102 1/2"

Inside Columns: 114 3/4"

Min. Bay Size: 12' x 24'

Ceiling Height Min: 12' / 12' 6"

Motor / Voltage 1Ø: 2 HP, 208-230V / 5 HP, 110V\*

Time of Full Rise and Descent: 45 seconds / 40 seconds  
25 seconds / 19 seconds\*

\* Actual rise and descent times vary depending on vehicle weight.

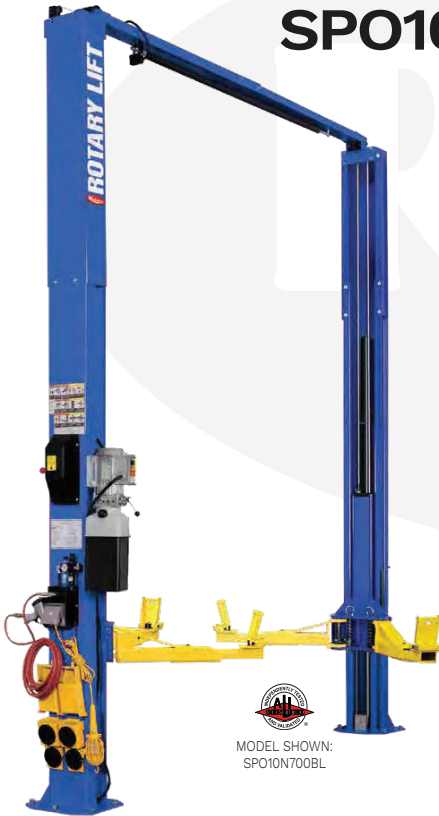

MODEL SHOWN:  
SPO10N700BL



MODEL SHOWN:  
SPO10N800BL

## SPO10

Standard 2-stage arms with exclusive three-position flip-up FA adapters

Flip-up adapters feature great strength in a simple design. The entire assembly is joined with a single pin providing stable support in any position.



Select product photography is shown with optional accessories that are not standard with each lift purchase.

## SPO10 SERIES LIFTS

ARE AVAILABLE WITH SHOCKWAVE-EQUIPPED POWER

SHOCKWAVE™ DC power with onboard 110v charger provides 2X the lifting speed of conventional lifts.

## SPO10 TRIO™

Includes TRIO™ 2-piece, three-stage arms with exclusive FA three-position adapters



### SYMMETRIC LIFT MODELS

BL = Blue / RD = Red

### CONVENTIONAL 2-STAGE ARMS

Flip Up Adapters (FA)

### THREE-STAGE TRIO ARMS

Flip Up Adapters (FA)

### CONVENTIONAL 3-STAGE ARMS

Truck Adapters (TA)

### CONVENTIONAL 3-STAGE ARMS

Round Adapters (RA)

	STANDARD	SPO10N700BL SPO10N700RD	SPO10N800BL SPO10N800RD	SPO10N5T0BL SPO10N5T0RD	SPO10N5G0BL SPO10N5G0RD
	<b>SHOCKWAVE EQUIPPED</b>	SPO10U705BL SPO10U705RD	SPO10U805BL SPO10U805RD	SPO10U5T5BL SPO10U5T5RD	SPO10U5G5BL SPO10U5G5RD
Rise*	STANDARD	72 5/8" - 78 1/8"	72 3/4" to 78 1/4"	72 11/16" to 75 3/16"	72 1/2" to 74 3/4"
	SHOCKWAVE	75 5/8" - 81 1/8"	75 3/4" to 81 1/4"	75 11/16" to 78 3/16"	75 1/2" to 77 3/4"
Front Arm Min/Max		31" - 54"	30 1/2" - 54 7/8"	27 1/2" / 59"	27 1/2" / 59"
Rear Arm Min/Max		31" - 54"	30 1/2" - 54 7/8"	27 1/2" / 59"	27 1/2" / 59"
Min Adapter Height		4 5/8"	4 3/4"	4 11/16"	4 1/2"

\* Rise measures lowest and highest position of the supplied adapters from floor to full cylinder stroke. Heights and widths reflect standard settings.  
\*\* Actual rise and descent times vary depending on vehicle weight. SPO10 lift colors come standard with your choice of red or blue.

## SPO10 TA

3-stage conventional arms with thread-up padded TA adapters. Optional SHOCKWAVE™ power available.

TA adapters are frame-engaging padded polymer adapters that thread-up for additional adapter reach.



## SPO10 RA

3-stage conventional arms with thread-up padded RA adapters. Optional SHOCKWAVE™ power available.

RA adapters are round padded polymer adapters that thread-up for additional positioning.





# SPO12 SERIES TWO POST LIFTS

12,000 lbs. CAPACITY / MEDIUM DUTY SYMMETRIC LIFT



Its size, wider drive-thru and larger footprint make the SPO12 the optimal 2 post lift for shops that work on taller, heavier vehicles.

Choose your:

- Lift height and width
- Power option
- Productivity accessories

## SPO12-TA

Symmetric lift with TA truck adapters and 3-stage arms for greater vehicle reach.

## SPO12-LC

LOW CEILING DESIGN  
Shorter overhead height designed for shops with lower ceiling bays.

- 11' 8" overall height
- 11' 9" minimum required ceiling height

## SPO12 WIDE

Wider stance provides an additional 17" of drive-thru width for larger trucks and vans.

Wide lift design provides the versatility for greater under vehicle access and less obstruction for service to battery electric vehicles.

### LIFT SHOWN: SPO12-SW

Includes SHOCKWAVE™ DC power with onboard 110v charger providing 2X the lifting speed of conventional lifts.



SCAN THIS VIDEO CODE TO LEARN ABOUT THE BENEFITS OF ROTARY SHOCKWAVE LIFTS

SPO12 SERIES LIFTS FEATURE three-stage arms and polymer Truck Adapters primarily used on framed vehicles.

Adjustable adapters thread-up and come with stackable inserts and storage rack. No metal



- Three-stage arms for greater reach
- Original "Double S" column design
- Performance tested to 20,000 lift cycles
- Nationwide support
- ALI Gold Certified

Standard SPO12 and SPO12-SW lifts are available in 4 adjustable lift height options / models

ADD UP TO 3' OF ADDITIONAL HEIGHT FOR EURO-STYLE CARGO VANS



### SYMMETRIC LIFT MODELS

BL = Blue / RD = Red

### CONVENTIONAL 3-STAGE ARMS

Truck Adapters (TA)

### CONVENTIONAL 3-STAGE ARMS

Truck Adapters (TA)

### CONVENTIONAL 3-STAGE ARMS

Truck Adapters (TA)

	STANDARD POWER	STANDARD MODEL SPO12N10T5BL SPO12N10T5RD	LOW CEILING MODEL SPO12N10TLBL SPO12N10TLRD	WIDE MODEL SPO12N10W6BL SPO12N10W6RD
	SHOCKWAVE EQUIPPED	SPO12U10T5BL SPO12U10T5RD	N/A	N/A
Rise*	STANDARD SHOCKWAVE	75 3/4" - 78 1/8" 75 3/4" - 78 1/8"	75 3/4" - 78 1/8" N/A	75 3/4" - 78 1/8" N/A
Overall Height		13' 8"	11' 10-3/4"	13' 11-1/2"
Overall Width		11' 5-5/8"	11' 5-5/8"	12' 10-5/8"
Drive-thru		102 3/8"	102 3/8"	119 3/8"
Inside Columns		114 7/8"	114 7/8"	131 7/8"
Front / Rear Arm Reach		Minimum: 27 1/2" Maximum: 59"		
Rear Arm Min/Max		27 1/2" / 59"		
Min Adapter Height		4 3/4"		
Min Bay Size		12' x 26'	12' x 26'	14' x 26'
Ceiling Height Min		13' 9"	12'	14' 1/2"
Motor / Voltage 1Ø		2 HP, 208-230V / 5 HP - 110V with SHOCKWAVE		
Time of Full Rise		60 seconds / 25 seconds with SHOCKWAVE		

\* Rise measures lowest and highest position of the supplied adapters from floor to full cylinder stroke.

\*\* Actual rise and descent times vary depending on vehicle weight. Heights and widths reflect standard settings. SPO12 lift colors come standard with your choice of red or blue.

# ROTARY SPO16

**PICK UP A GREATER VARIETY OF VEHICLES FASTER AND EASIER ALL ON ONE HEAVY DUTY 2-POST LIFT**

Packed with industry-leading features, the new SPO16 lift combines high capacity, a low profile stance, wider options and extreme arm reach possibilities with patented lifting speed! All of Rotary's award-winning features can be found on our heavy-duty two-post lifts. With options like low ceiling and extended width models, you can rest assured we have a lift for your job.





## DESCRIPTION

### TRIO™ ARM SYSTEM: THREE STAGES OF FLEXIBILITY IN A TWO-PIECE ARM!

There are no additional heavy inner arms to extend; you can move the adapter within the arm easily. Trio™ arms give you 22% greater reach than conventional arms. This translates into tire clearance and greater retraction to accommodate more vehicles in the bay.



Maximum Adapter Height: **8 1/32"**  
(203mm)



10" High Step Height: **15 31/32"**  
(406-470mm)

### ADAPTERS, SPOTTING DISHES AND SHOCKWAVE™

- The SPO20 comes with a ton of tools to help make your technicians' lives easier. Also included with the lift purchase are adapters, extensions, and spotting dishes, which are exclusive to Rotary. This all helps to make your shop and this lift a versatile combination.
- Adjustable thread-up adapters come standard.
- Clip-on rubber pads come standard.
- 10" (2 each) and 5" (4 each) stackable extensions come standard.
- Two (2) wheel spotting dishes come standard.

# NEW LT33A

AIR - HYDRAULIC LIFTING TABLE  
3,300 lbs. CAPACITY

Experience the ultimate flexibility in lift positioning and ease of use with these patent-pending features.

The LT33A single section scissor lift design has a wide, stable base to help technicians securely and efficiently remove, and install heavy vehicle components from electric battery packs, engines, and transmissions.



## 1 SPLIT SLIDING TOP



The lift platform extends an additional 8" allowing the table to shift in sections. This feature eliminates the need to move the entire table for multi-positioning of larger loads.



Platform easily locks and unlocks for fine adjustment of under vehicle placement.

## 2 REAR PLATFORM TILT ADJUSTMENT

Conveniently adjust the table while under load with no need to remove battery, parts, or tools from platform. Fine adjust the tabletop with the object being removed or installed on the vehicle by positively tilting from the rear by up to 1°.



To tilt, thread jack screws located at the rear of lift table upward using allen wrench or allen socket until correct angle is met.

The table platform adjusts up to a 1° tilt angle to adapt to an uneven floor to be level with vehicle.

## 3 SIDE TO SIDE PLATFORM ALIGNMENT

Easily shift tabletop left or right by 1" by unlatching red toggle handles on mid table and pushing or pulling "U" shaped handles until desired position is reached. Reclamp handles to lock the new platform position.



## 4 AIR RELEASED MECHANICAL LOCKS

This redundant safety measure secures the lift (versus relying solely on the hydraulic system) with additional locking security. Standard with 9 locking positions at every 2-3/4", the first lock is at a 32" table top height.



Locks shown in the raised position during lowering of table  
Compliant with Standards for Garage Equipment  
- adds additional support and safety guidelines



Single hydraulic cylinder operation



SCAN TO VIEW  
PRODUCT VIDEO



# RT30

**SERVICE REPAIR TABLE**  
**3,000 lbs. CAPACITY**

## CREATE MORE REPAIR SPACE!

### PATENT-PENDING REPAIR TABLE EXPANDS YOUR SERVICE CAPABILITIES

Mount the RT30 on top of the LT35A scissor lift table to support the removal of EV propulsion batteries without moving heavy components to another table for service!



### CREATE MULTIPLE REPAIR STATIONS!

Use numerous RT30 repair tables with a single LT35A lift table and reduce the need for multiple lift tables.



Easily position lift table between yellow RT30 self-aligning stop brackets.

SHOWN ABOVE: RT30 repair table mounted to 3,500 lbs. capacity LT35A scissor lift table



Legs swing and lock in the up position for transport and down into the upright position creating a stand alone table.



Adjustable feet on each leg table can be raised or lowered to level the table surface.

Configurable aluminum backed polymer pads insulate battery from the table. Plates can be flipped if a hard surface is required.



Front and rear table ends extend to support different size batteries and provides additional access to battery fastening bolts.

#### SPECIFICATIONS RT30-0000YBK

Lift Table Capacity	3,000 lbs.
Minimum Height	33 7/8"
Maximum Height	38 1/8"
Tabletop Width	42"
Tabletop Length	Minimum: 77" Maximum: 106 1/2"
Overall Weight	400 lbs.



# BATPRO



## BATPRO PORTABLE FULL-RISE X-LIFT TABLE

The BATPRO is a portable full-rise X-lift table that is perfect for EV battery pack replacement. This space-saving scissor lift is ideal for handling EV batteries effectively because of its small size and mobility throughout the workshop. To elevate, lower, and move objects like a high voltage electric vehicle (EV) battery, an engine, a transmission, a seat, a fuel tank, or an axle.

### DESCRIPTION:

- Their portable design makes transporting items from one place to another easy.
- For secure handling of batteries, a range of lifting brackets are accommodated by uniform mounting holes on the top surface.
- Low rolling resistance and easy maneuverability are delivered by a steering arm of the pallet-jack type.
- A typical hand pendant station enables users to control the lift during all lifting activities remotely.
- The mechanism for tilting the top surface forward, backward, and sideways to align the electric batteries more precisely.

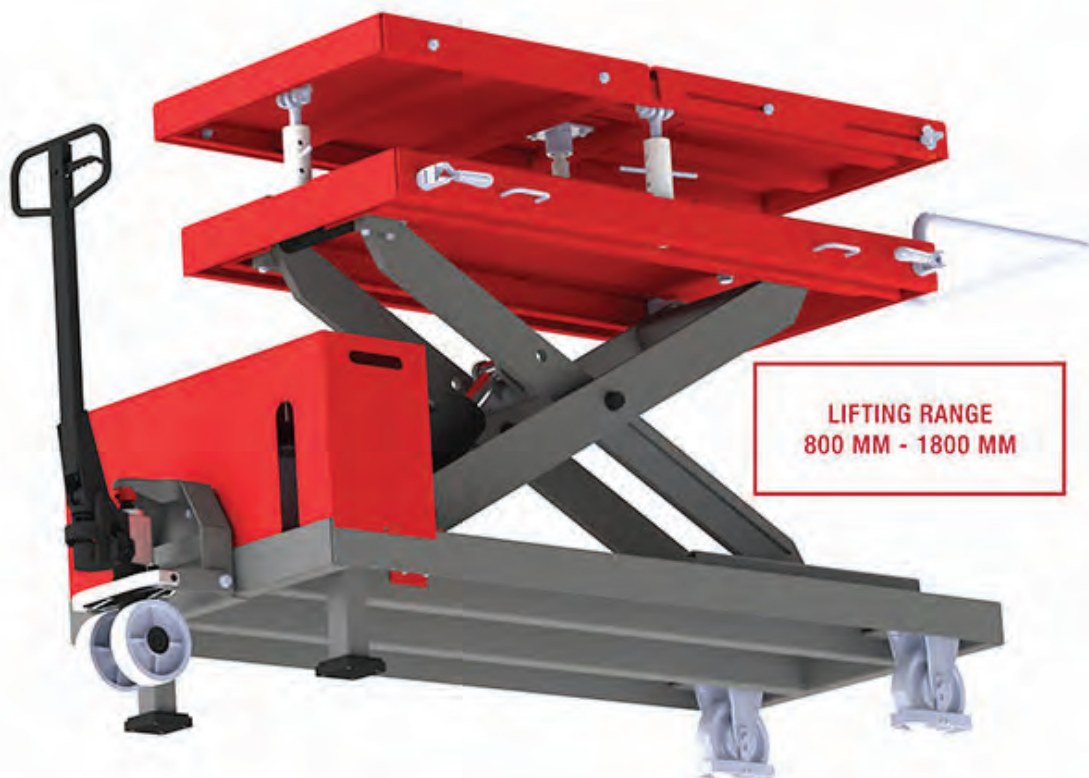

# CARTAR E-GLIDEMASTER

## THE NEW GENERATION OF MOBILE CAR LIFTS FOR THE MODERN WORKSHOP AND AUTO BODY SHOPS.

With the Cartar e-Glidemaster, you can easily and safely lift and move your damaged cars through your workshop. It is powered by a standard battery and can be used inside or outside.

The Cartar e-Glidemaster Mobile lift is the first truly mobile hoist that allows you to elevate a damaged car from ground height and move that car and lift safely around your workshop. There are many lifts that are portable, but once the car is elevated, they become a static fixture. Only the Cartar Mobile Lift is truly mobile.

### DESCRIPTION

- Battery Power
- Total freedom to Lift & Move
- 5 days of Battery Grunt
- 2600 kg max lift
- 100 mm ground height
- No Hoses
- No Cables
- No Airlines
- No Installation Costs

**CARTAR**   
*mobile hoist technology*



# ROLLING EVO

SEB.P | SEB.E | SEP.P | SEP.E

THE ONLY PLATFORM-LIFT WITH WHICH A VEHICLE CAN BE MOVED

- Adjustable platforms positioning makes it suitable for both city cars and GT cars.
- Anti-rolling safety system on all platforms.
- Quick and easy vehicle boarding, no manual intervention.
- Large diameter wheels to facilitate the vehicle movement, just one operator required.
- Low profile, 10cm only as minimum height.
- Can be used with under-body lifting arms in place of wheels platform.



**SEP.E**

Rolling Evo with platforms and power unit



**SEP.P**

Rolling Evo with platforms and pump

# THE NEW AIR RISE 5!



➤➤ Capacity: 3500kg

➤➤ Pneumatic Powered: 8 bar

➤➤ 5 Different Motion

➤➤ Length: 3600mm

➤➤ Width: 2150mm

➤➤ Min/Max Height:  
143/650 mm

# CMO UTP UP TO PAINT

Cod.  
UTPP  
UTPP.PAP  
UTS.E  
UTS.PAP



Cod. BS  
Cod. BSR

# SPIDER ROLLING LIFT

THE ONLY EQUIPMENT THAT ALLOWS THE END USER TO MOVE THE VEHICLE  
TOGETHER WITH THE LIFT ALL AROUND THE WORK-SHOP





# GLUE PULLING



**CALL US TODAY**

**FOR THE BEST  
EQUIPMENT & SERVICE!**

(855) 999.SCCE



# SPEEDLINE GLUE SYSTEM

## ADVANCED REPAIR EQUIPMENT FOR THE TECHNICIAN'S TOOLBOX

The Glue Repair section of BETAG's outer panel repair toolbox contains a range of advanced equipment designed to enable technicians to work precisely and efficiently.

Glue has a wide range of applications across steel and aluminum panel repair. It can be used as a less invasive repair method in isolation for smaller damage – and is a quick and easy means of significantly reducing or completely repairing larger damage, particularly when used in combination with some of BETAG's other repair tools and techniques.

## DESCRIPTION

- Speedline system is available in Eco, Business and Pro versions
- Can be configured as a single comprehensive system or several satellite systems



# SPEEDLINE PRO STATION

**PROVIDES A WIDE RANGE OF TOOLS TO TACKLE ANY GLUE PANEL REPAIR.**

The Speedline Kit, which contains the Speedline Puller, and a wide range of Speedline tabs. The Accessory Kit has a large selection of both large and small tabs, and a wide range of Pulling Elements. Two bridges are also included, with the Business for larger areas, aided by adjustable feet, and the Eco Bridge, which is ideal for medium panel and quick applications.

## **SPECIFICATIONS**

### Parts/Accessories:

- Dentliner
- Speedline Set
- Speedline Accessory Set
- Speedline S-Bridge
- Edge Lifter
- Speedline FL Hammer
- Small Trolley



# SPEEDLINE ECO SYSTEM

**IT'S QUICK AND EASY USE MAKES IT IDEAL FOR ANY TECHNICIAN.**

The Speedline Eco System is a versatile bridge pulling system for quick glue panel repairs.

## **SPECIFICATIONS**

Parts/Accessories:

- S-Bridge
- Speedline 8
- Speedline 16
- Speedline 24
- Pulling Bar
- Speedline Pulling Element S
- Speedline Pulling Element SM
- Speedline Pulling Element M
- Beige Glue
- Blue Glue
- Speedline Bridge Adaptor



# SPEEDLINE ACCESSORY KIT

**IS A GREAT SUPPLEMENT TO ANY BRIDGE SYSTEM, LIKE THE FLATLINER.**

With the addition of this kit, you can use the existing system on any glue panel repair. It has a large selection of Speedlines, Pull Knobs, and Pulling Element attachments.

## **SPECIFICATIONS**

### Parts/Accessories:

- 2 X Speedline Pack
- Speedline Pulling Element S
- Speedline Pulling Element SM
- Speedline Pulling Element M
- 5 x Speedline Bit M6
- 5 x Pull Knob Round
- 5 x Pull Knob Big Round
- 5 x Pull Knob Flat
- 5 x Pull Knob Big Flat
- 5 x Pull Knob GT15
- 5 x Pull Knob GT25
- 5 x Pull Knob HT15
- 5 x Pull Knob HT 20
- 5 x Pull Knob HT30
- Power Knob Set
- Beige Glue
- Blue Glue
- Speedline Bridge Adaptor





# VACUUM SYSTEMS



**CALL US TODAY**

**FOR THE BEST  
EQUIPMENT & SERVICE!**

(855) 999.SCCE

## EUROVAC II - PNEUMATIC SANDING PORTABLE

*Keep your facility safe & clean with a Eurovac portable vacuum system*



The Eurovac II portable is powered by compressed air being forced through a venturi to create a powerful vacuum. Using compressed air eliminates the chance of a dust or gas explosion as there is no sparking motor. To meet NFPA codes, the system is grounded and the vacuum hoses and cuffs are static conductive.

- System Uses: Safely collects fine powders, explosive dusts and debris: It can be used in Class I-Group D and Class II Groups E, F & G hazardous locations.
- Superior Filtration: True cyclonic filtration removes virtually all the dust prior to the secondary cartridge filter. Final polyester cartridge filter is efficient up to 99.93% at 3 micron or larger.
- Powerful venturi vacuum capable of handling two technicians sanding at the same time.
- Manual flow valve on the air intake to ensure you get just the proper amount of airflow and suction for your application.
- Quiet operation... venturi housing is insulated and baffled for sound.
- HEPA filtration is available by adding a chamber between the pump and regular filters. The HEPA filter removes the remaining 99.97% of sanding dust to a minimum of .3 micron particle.

Eurovac offers a complete line of vacuum assist hand tools, abrasives & cleaning tools

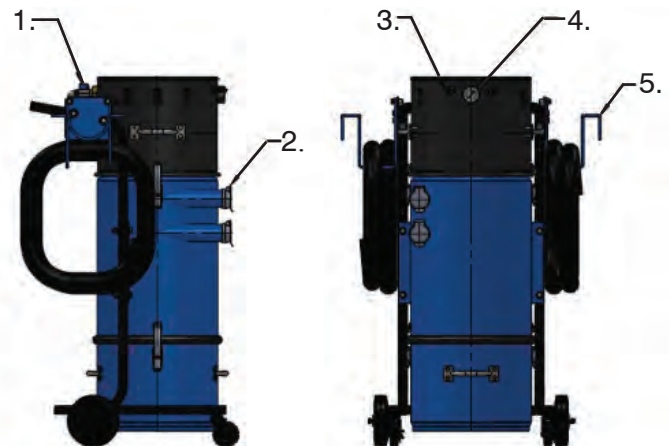

1. Ball valve and high flow 1/2" fitting
2. 1.5" inlet valve (2)
3. 1.25" compressed air connection for air tool (2)
4. Compressed air gauge
5. Sanding tool holder/hose hanger (2)

## EUROVAC EXPLOSION-PROOF PORTABLE

*Eliminate explosive powder and dust.*



### PRODUCT DESCRIPTION

The Eurovac Explosion Proof portable vacuum safely collects explosive powders and dust.

- Powerful 110 volt, 12 amp, 1300 watt explosion proof motor and vacuum pump provide 140 CFM and 70" W.C. vacuum.
- Explosion proof starter and junction box (customer to supply cord and plug).
- Unit is grounded to eliminate static build-up.
- Excellent filtration - the tangential entry and the cyclonic cone remove 85% of the dust before it reaches the large 8" x 16" polyester cartridge filter (22 sq ft of filter media). Final HEPA filter (99.97% efficient to .3 microns).
- Large 10 gallon collection canister. A 5 gallon collection canister is available for aluminum applications.
- Mounted on a heavy duty welded tubular steel frame with a powder coat finish and with 4" poly rear wheels and 2" swivel (lockable) front wheels.  
Unit is available in Stainless Steel.
- Eurovac offers a full range of anti-static conductive vacuum hoses, wands and cleaning tools.

### SPECIFICATIONS

SPECIFICATIONS		
Voltage	volts	120
Current Draw	amps	12
Power	watts	1300
Waterlift, max.	inches H2O	70
Airflow, max	cfm	140
Collection Canister	gallons	5 or 10
Filter Area	sq. ft.	22
Weight	lbs.	155
Sound level @ 10'	dB(A)	78
HEPA filter efficiency,	%	99.97% @ 0.3 microns

### CLASSIFICATIONS

Motor and fan are rated for Class II-Groups E, F & G hazardous locations.

- Class II, Group E - Atmospheres containing metal dust, including magnesium, aluminum, and their commercial alloys.
- Class II, Group F - Atmospheres containing carbon black, coal, or coke dust.
- Class II, Group G - Atmospheres containing flour, starch, or grain dusts.

# EUROVAC

## EUROVAC II - WET-MIX DUST COLLECTOR

*Eliminate dust with a Eurovac system and source capture sanding tools*



\*Patent Pending

### How the Unit Works:

Dust is drawn into the unit through and forced down through a venturi, deep into the water. The water acts as a separator, and the majority of the dust particles fall to the bottom of the unit immediately. Those particles that manage to escape this first stage of cleaning, are forced through thick curtains of water, and are deflected by a series of baffles into the water turbulence, separating the remaining dust from the air. The moist clean air is drawn through the unit by an internally fitted blower, passes through a stainless steel mist eliminator, where the moisture is removed from the clean air. The dust which has settled to the bottom of the unit is removed through the sludge drain valve.

### Features:

- Powerful 13.8 amp motor with sealed bearings built to handle moist air from wet collector. 1560 watt pump produces 145" of water column; 140 free flow CFM. *Has enough power for 2 technicians to sand with orbital sanders at the same time.*
- Quiet operation particularly for fine dust... motor housing is insulated and baffled for sound.
- On/off feature...motor is turned on and off automatically by air switches when pneumatic tools are activated. This increases the life of the motor and reduces energy costs of running the motor.
- Includes a plastic sight glass to determine when water should be added.
- Stainless steel mist eliminator.
- 2" ball valve & hose at the bottom of the separator for removing sludge.

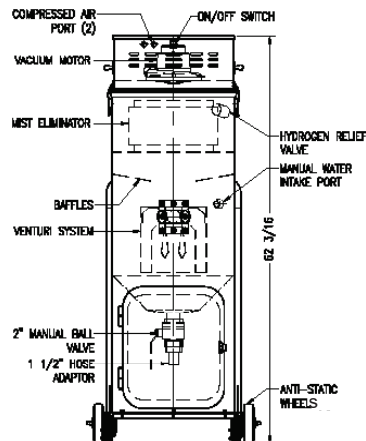
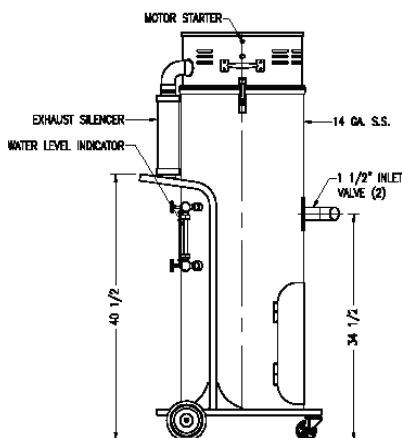

### Automotive & Industrial Applications



\*For use in ordinary locations

Specialists in Dust and Fume  
Extraction Systems



855.999.SCCE  
sccusa.com





# COMPRESSORS



**CALL US TODAY**

**FOR THE BEST  
EQUIPMENT & SERVICE!**

(855) 999.SCCE



# WERTHER KV 5.5-20 HP ROTARY SCREW COMPRESSORS

The KV series' modular design offers versatility, guaranteeing the ideal compressed air solution tailored to diverse air requirements and applications. Whether for industrial operations, automotive workshops, or manufacturing facilities, the KV series stands as a testament to innovation, reliability, and efficiency in compressed air technology. Experience the difference today with the KV series Quiet Rotary Screw air compressor.

## SPECIFICATIONS

- PACK SMART V60 - V75.
- ELECTRONIC CONTROL PANEL.
- LATEST DESIGN IN HIGH EFFICIENCY AND PERFORMANCE WYW DELTA ELECTRIC MOTOR.
- LARGE AIR-OIL COOLER.
- THERMOSTATICALLY CONTROLLED COOLING FAN.
- POLY-V BELT DRIVE.





# PREVOST PIPING SYSTEM



- Ø in
- 1/2"
- 3/4"
- 1"
- 1 1/4"
- 1 1/2"
- 2"
- 2 1/2"
- 3"
- 4"
- 6"

CONNECTED TO INNOVATION



# PAINT



**CALL US TODAY**

**FOR THE BEST  
EQUIPMENT & SERVICE!**

(855) 999.SCCE

# Walcom

**Genesi Carbonio**  
**360 evo HALO Clear**



**Genesi Carbonio**  
**360 evo HALO Base**



**Genesi Carbonio**  
**360 evo HVLP**



**Genesi Carbonio**  
**360 evo GEO**



# EXODUS

## Premium Spray Paint Gun

Our EXODUS series sprayer is designed to be ergonomic and has proven to push the industry's boundaries for transfer efficiency and material savings. Optimized for speed, material transfer, and ease of use the Exodus series is the ideal option for color coverage, metallic consistency, pearl coat uniformity, and obtaining the required clear coat finish.

Exodus Model	Air Cap	Needle Size	Part Number
OP Color Coat	Optimized Silver	1.3 mm	L3-EX130P
OP Clear Coat	Optimized Black	1.5 mm	L3-EX150P
HVLP Color Coat	HVLP Silver	1.3 mm	L3-EX13HV
HVLP Clear Coat	HVLP Black	1.5 mm	L3-EX15HV

The EXODUS OP series (Optimized Pressure) intuitively provides better atomization at low pressure, limiting overspray/bounce back and allowing more paint to stick to the panel.

The OP technology helps to produce smooth quality results that the collision and restoration markets require.

The Speed and Adjustability of the EXODUS OP series best meet the needs of each painter's individual painting style, for example; the OP gun can be set up for a faster-moving profile and can be easily adjusted to get manufacturer-required orange peel in clear coat applications.

The EXODUS series spray paint guns are some of the most lightweight full-size spray guns available on the market weighing in at 11.8 ounces. Designed to reduce ergonomic strain, the Exodus provides a low trigger load creating a smooth and stress-free trigger motion.

Each of our Exodus models comes with our proprietary Snap-2 adapter.

The dynamic chamber of the Exodus OP achieves an air volume that exceeds most other spray guns currently available. Our Optimized Pressure technology supplies micro-fine atomization with a wide spraying pattern by supplying stable air flow to the spray gun nozzle.

The Exodus OP models have the ability to achieve a micro fine particle size of 17 microns ( $\mu\text{m}$ ) approximate. This is accomplished with large volumes of air provided by the Exodus' Optimized Pressure air chamber. Refined atomization benefits the user by allowing for more control over color coats, blends, metallic, pearl coats and clear coat finishes.

The Exodus OP Clear Coat 1.5 provides an incredibly competitive spray pattern in both height and width against other leading brands within the industry (11.8" approximate). The Exodus series offers these features while also being one of the smallest in profile and lightweight full size spray guns available.



# Walcom

## Evo 360 mask



The 360 EVO Mask is the perfect companion for anyone that works in heavily polluted, smelly or even toxic environments. Protects user from organic, inorganic and acidic gases and vapors. Great for contract painters and workers, with no need to rely on an unknown filtration system. Highest safety class (TH3) respiratory protection from fumes, gas, smoke, aerosols, and dust. Integrated, automatic air flow control and calibration. ATEX Zone 2 and 22 certified.

# SunPro

## Spray Paint Gun Attachment / Color Match Light

The Luma III SunPro Spray Gun Light is our new spray paint gun light attachment, a sunlight-accurate LED attachment. The SunPro offers an incredible amount of illumination with industry-leading color-matching precision, from the palm of your hand to the tip of your spray gun.

- 98 CRI (color rendering index) sunlight-accurate LED output
- 5000 Kelvin color temp
- 3300 Lumens/Lux flood lighting output (relative to 10 inches from the panel)
- Spanning 4 ft of even/smooth flood light at 6 – 10 inches from the panel
- Approximately 12 hours of battery run time
- Integrated wireless charging and charging dock
- Chemical-resistant build material/and fully sealed system
- Sapphire glass lens
- Universal Snap-2 attachment design

Each SunPro comes with a charging base and a FREE Snap-2 adapter.

Adaptability is a crucial feature of the SunPro Spray Paint Gun Light Attachment. It utilizes our Snap-2 Universal Mount System so that your SunPro can snap to a range of different spray guns (Luma III, SATA, Anest Iwata, Devilbiss, Sagola, Graco, Walcom, etc.) by attaching it from one spray gun to another with ease and security.

One of the most notable features of the SunPro is its exceptional color rendering capabilities, which are measured by its high Color Rendering Index (CRI) rating of 98. CRI measures how well a light source reproduces colors as they appear in natural daylight. A CRI rating of 98 means that the SunPro light attachment provides one of the most accurate representations of colors in the industry, making it the perfect tool for color matching and other precision painting applications.





# Snap-2

## Spray Gun Adapter for SunPro

Our Luma III Snap-2 spray gun adapter is a universal style system for our SunPro spray gun light.

Each Snap-2 adapter is designed to securely fit the selected spray gun specifically but will fit the SunPro universally. This allows you to move your SunPro light from spray gun to spray gun with ease. Fitting the most popular gravity-fed and pressure-fed spray guns on the market (SATA, Anest Iwata, Devilbiss, Sagola, 3M, Graco Walcom, Fuji and more).

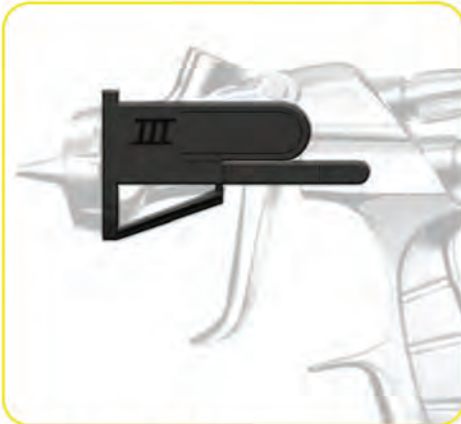
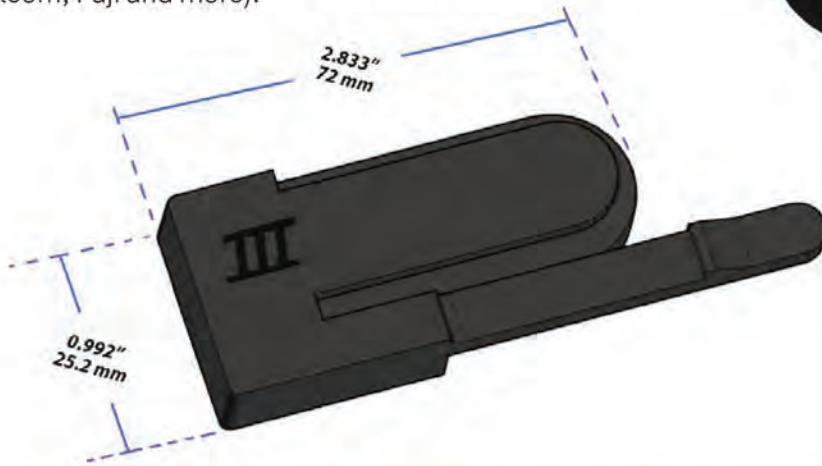

## Needle Nozzle Kit (for Exodus spray paint gun)

Luma III Exodus needle/nozzle kit. Select from our 1.3 and 1.5 needle/nozzle kit sizes. Both 1.3 and 1.5 needle nozzle kits are compatible with both our HVLP and OP Exodus models.

Size description is identified on the side of the nozzle (13CR = 1.3 and 15CR = 1.5).



# Spray Suit

## Professional Anti-Static Paint Suit

The Luma III Spray Paint Suit is **designed for life in the spray booth.**

Our **premium anti-static spray suit** is a great addition to any painters arsenal and provides an optimal level of protection. Safety of the painter, minimizing static buildup, and a lower dust transfer rate are key variables to a great paint finish and a healthy shop environment.

- Anti-Static and Lightweight
- Double Zipper
- Ventilated Under Arm
- Back Vents
- Ankle Straps
- Pocket Access
- Built Knee Pads
- Washable / Reusable

Our hood design offers generous headspace and flexibility for maximum freedom of movement. This innovative automotive paint suit provides incredible performance that keeps up with you in the spray booth. Weighing in at roughly 14 to 24 ounces (depending on size) our suit is proven to be a weight off your shoulders.



**Gender:** Male & Female  
**Suit Size:** XS - 4XL  
**Suit Color:** Blue/Black & Grey/Black  
**SKU:** L3SUIT



# Spray Case

## Booth Spray Paint Gun Management Cabinet

Booth organization is key to a quick and effective painting environment, and the Luma III Spray case gets it done! Our Spray Case offers an optimal level of variability and is a great way to streamline any process within the paint booth. Built from powder-coated steel and heavy-duty hanging magnets makes the SPRAY CASE the perfect booth tool.

- 2 spray gun hangers (compatible with 90mL, 180mL, 400mL, 600mL, and 850mL sized pps/disposable paint cup systems and regular hard cups)
- 2 spray bottle hangers (compatible with traditional chemical and water pump top sprayers used for surface prep) / can double as air hose storage
- Storage space (great for tack rags, razor blades, antistatic devices, fine line, etc.)
- Ability to attach on both metal and non-metal surfaces



Equipped with four 60 lb pull magnets, attaching to the booth wall is quick, simple and strong. Keep you booth organized and simple with the Spray Case by Luma 3.



# Air Hose Hang System

Magnetic Booth Attachment for Spray Paint Hoses

The Air Hose Hang System by Luma III is a two part magnetic holder used to conveniently keep 3/8 inch air hose off of the spray booth floor. Designed for professionals and engineered for any spray painting situation, this system easily attaches to any metal spray paint booth and 3/8 inch air hose specifically used for spray painting. Our Air Hose Hang System is built to withstand booth bake cycles up to 200° F, and includes two parts (wall hanger/receiver & air hose clamp/collar).

## Magnetic Wall Hanger

- Contains two heavy duty built in magnets for attaching to the paint booth wall, along with multiple micro magnets to receive and help secure the air hose clamp when not in use. Built from high quality composites offering long term durability, and heat resistance.

## Air Hose Clamp

- Built from carbon fiber reinforced nylon, this clamp/collar is incredibly durable and lightweight. Weighing in at under 1 ounce (0.75 oz) the clamp isn't even noticeable on an outstretched arm. This small design houses four micro magnets to help secure your air hose to the Wall Hanger when the air hose is not in use.



# 360 True Light Evo Meter



The first light and integrated distance digital meter. Set your distance and keep it in control. Set spray distance, display shows it in real time as well as battery stamina and light intensity. Real time feedback with arrows to indicate if too close or too far from preset. Go-pro compatible integrated system -included magnetic kit for standalone use. True sun light for easier mottle control and color match checking.



## 360 TRUE LIGHT

V.2025/UD\_EN

Brand	Type	Item id. (3 Pcs)	Item letter
WALCOM	GENESI CARBONIO	90242-A	A
WALCOM	GENESI Alluminio	90242-A	A
WALCOM	GENESI TOP LINE	90242-A	A
WALCOM	SUM KOMBAT/XLIGHT	90242-C	C
WALCOM	EGO CARBONIO 190	90242-D	D
DEVILBISS	GTI PRO light	90242-A	A
DEVILBISS	DV1	90242-A	A
SATA	5500	90242-B	B
SATA	5000	90242-B	B
SATA	4000	90242-B	B
SATA	3000	90242-E	E
IWATA	AZ3	90242-B	B
IWATA	WS400 (Pinin.)	90242-E	E
IWATA	WS400 2 (Pinin.)	90242-E	E
IWATA	W400 (Bellaria)	90242-C	C
SAGOLA	4500	90242-E	E
SAGOLA	4600	90242-E	E



## EASY S

Spray gun cleaner for solvent paints. For more accurate spray gun cleaning in three phases: atomized clean solvent flow clean solvent flow recycled solvent flow.



**Faster Repairs. Better Results.**

## **HANDHELD** | Accelerated Curing System

Get your shop running more efficiently in minutes.

Rapidly cure filler and coatings in three minutes or less with the REVO Handheld. This powerful, lightweight tool is ideal for fast plastic repairs, but can also be used in every step of the repair process. With the REVO Handheld, you can repair small areas, soften glass seals, heat aluminum to repair aluminum-body vehicles, as well as remove dents, emblems, vinyl graphics and adhesives. The REVO Handheld allows you to get more repairs done faster, saving you time and money.



---

**THE ULTIMATE TOOL FOR BODY REPAIRS**

---

## RAPID | Accelerated Curing System

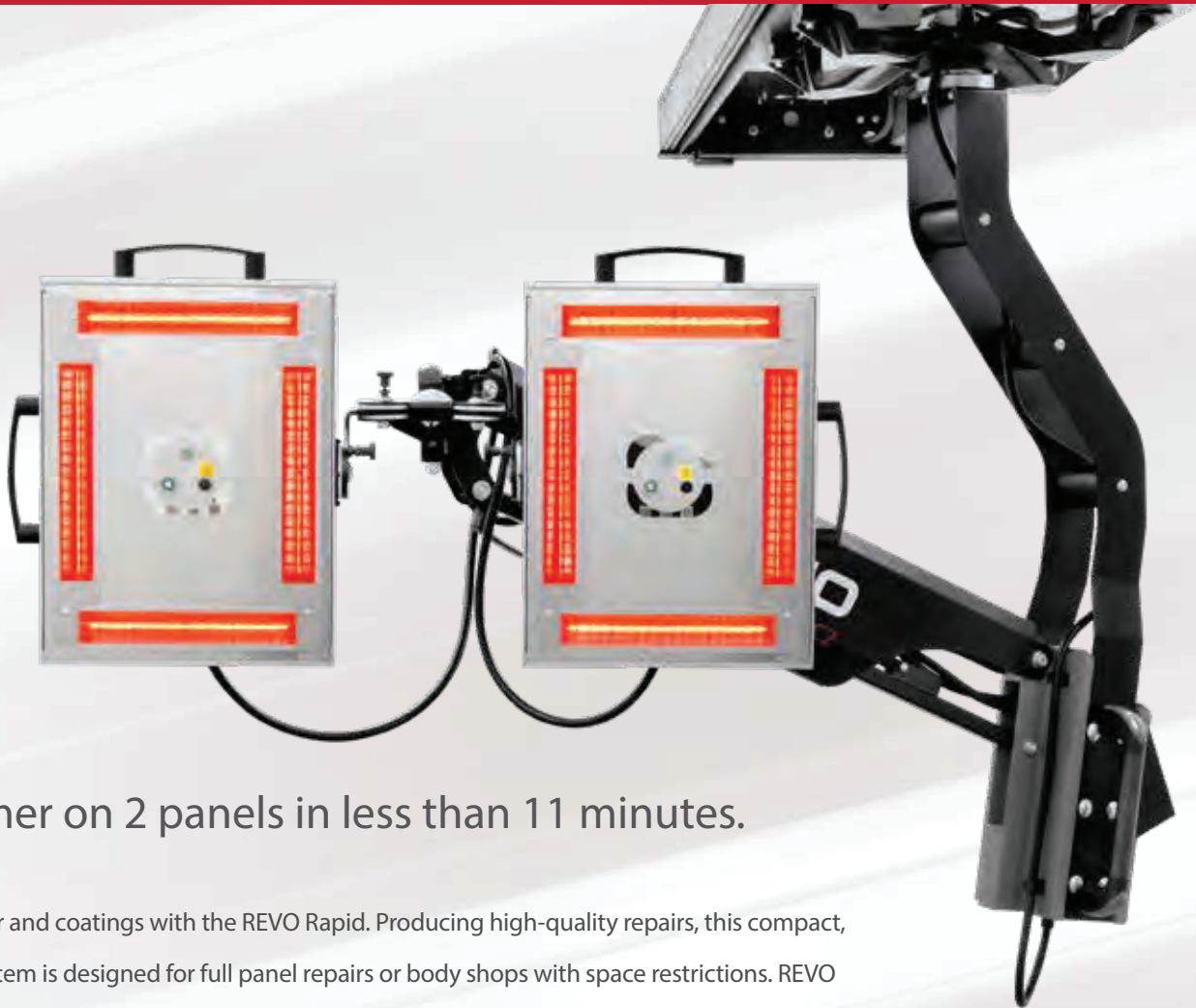

Cure primer on 2 panels in less than 11 minutes.

Quickly cure filler and coatings with the REVO Rapid. Producing high-quality repairs, this compact, two-cassette system is designed for full panel repairs or body shops with space restrictions. REVO Rapid is perfect for smaller, quick repair jobs of one to two panels, and can reach any part of a vehicle. Safely and efficiently cure coatings on two different panels simultaneously, while maintaining the correct temperature. REVO Rapid is ideal in prep areas and GFS' Closed-Top Open-Front (CTOF) Booths. Choose from an overhead rail system (OR2) or mobile system on wheels (MC2).

---

THE ULTIMATE TOOL FOR PAINT AND PREP

---





Faster Repairs. Better Results.

## SPOT | Accelerated Curing System

Cure 2- to 4-hour primer  
in 6 to 8 minutes.

Significantly reduce primer cure time with the REVO Spot. This impressive tool is the ideal solution to quickly cure small, 3-by-3-foot areas. Available on a rolling cart, the single-cassette REVO Spot can be effortlessly moved into any paint booth, prep station or virtually any area in a shop. In addition to curing body filler, as well as spray-on and roll-on primer, this unit is well suited for applications like aluminum repair, bumper repair and dent removal.



---

THE ULTIMATE TOOL FOR PRIMER AND FILLER

---

# R<sup>UP</sup> REVO



Is the revolutionary system made by Bellini Systems that allows infrared panels installation inside a standard spray booth, increasing the drying performance, reducing drying time and costs in each curing cycle.

The system can be installed in every existing spray booth, with different width and length.

Installing **R<sup>UP</sup> REVO** is a very simple operation that will stop you spray booth for only few days.

With **R<sup>UP</sup> REVO** it's possible to install the IR panels on side walls, back side wall and in some instances the plenum.

## SMART TECHNOLOGY



# R<sup>HD</sup> REVO





**PosiTector® 200 B1**



**PosiTector® 200 B3**



**PosiTector® 6000 FN1**



**PosiTector® 6000 FN3**



**PosiTest® DFT Combo**



**PosiTest® DFT Ferrous**



**PosiTest® PC**



# HAND TOOLS



**CALL US TODAY**

**FOR THE BEST  
EQUIPMENT & SERVICE!**

(855) 999.SCCE

# MG2K-040 MicroGrip

The world's smallest locking tool! Perpendicular clamping. Ergonomical design with smooth rounded edges. Innovative leverage system combined with prime materials. Straight line motion of mobile jaw. Adjustable screw double-acts as mobile jaw. Also available in a 4 pieces kit and a 24 pieces. Point of Sale display unit.



## Welding Locking Pliers Essential KIT1

224-12 CClamp, ideal for parallel tightening of metal, wood, plastics, etc. It allows parallel tightening even on inclined surfaces without damaging them.

125-09 Locking U-Clamp for a firm grip of two pieces in welding, assembly and vehicle repair operations. Good visibility in welding.

111-10 Locking pliers with large jaw capacity, indicated for round shapes. Used in all metal, wood, DIY, welding, plumbing, heating, workshops. firm grip TOP tool.

224-18 CClamp, ideal for parallel tightening of metal, wood, plastics, etc. It allows parallel tightening even on inclined surfaces without damaging them. It has a reach of 240mm in length.

111-07 Locking pliers with large jaw capacity, indicated for round shapes. Used in all metal, wood, DIY, welding, plumbing, heating, workshops. firm grip TOP tool.

1010 10" Grip Holder. Turns Locking Pliers & Clamps into a Mini Workbench. Versatile and portable for HANDS-FREE jobs indoor and outdoor.



**SLOT PUNCH  
8X20MM**



**DUAL TEMPERATURE  
HEAT GUN 570F 1000F**



**M18 FUEL 21MM  
RANDOM ORBITAL  
POLISHER**



**M18 FUEL 7" / 9" LARGE  
ANGLE GRINDER**



**PISTOL GRIP AIR  
DIE GRINDER**



**M18 CORDLESS COMP  
1/2" DRILL DRIVER**



**BLAIR ENFORCER  
SPOT WELD DRILL**



**M18™ RANDOM  
ORBIT SANDER**



**M12 FUEL™ 1/2" DIGITAL  
TORQUE WRENCH  
W/ ONE-KEY™**





# SHOP TOOLS



**CALL US TODAY**

**FOR THE BEST  
EQUIPMENT & SERVICE!**

(855) 999.SCCE

**BRANICK  
7600 STRUT  
SPRING  
COMPRESSOR**



**K TOOL  
INTERNATIONAL  
ENGINE CRANE  
2 TON FOLDABLE**



**K TOOL  
INTERNATIONAL  
JACK STANDS  
22 TON HD**



**OMEGA  
25058C  
FLOOR  
JACK 5TON**



**LINCOLN  
LUBRICATION  
STEEL FUEL  
CADDY**



**SCHUMACHER  
ELECTRIC MANUAL  
WHEEL  
CHARGER**



**BT600**





# Discover the SCCE *Training Center*

## Unlock the Power of Knowledge and Equipment Mastery

See everything we have to offer at SCCE's State-of-the-Art Training Center! Whether you want to enhance your skills, familiarize yourself with the latest collision repair equipment, or get hands-on experience, our facility is the perfect place to learn and grow.



## Why Visit Our Training Center?

- ✓ Hands-On Demonstrations: See and test top-of-the-line collision repair equipment.
- ✓ Expert Instructors: Learn from the industry's best with years of practical experience.
- ✓ Cutting-Edge Tools: Stay ahead of the competition with the newest tools and technologies.



## Ask Us About *Upcoming Classes!*

From beginner to advanced, we offer a variety of classes designed to meet the needs of every technician.

## Ready to Elevate Your Skills?

Contact us today to schedule a visit or inquire about class dates.



18215 South Pasadena St. Unit A 100  
Lake Elsinore, CA 92530



855.999.SCCE



customerservice@sceusa.com



sceusa.com

