



TECHNICIAN TRUSTED.
INDUSTRY RESPECTED.

PRODUCT CATALOG



SOUTHERN CALIFORNIA COLLISION EQUIPMENT



TRUSTED BY THE AUTO BODY REPAIR COMMUNITY

Southern California Collision Equipment was founded in 2010 by Chris and Ian Stoffel. Our mission is to provide premium collision equipment that increases work efficiency for mechanics and technicians across the nation. With over a decade in the industry, we've dedicated ourselves to serving our customers, surpassing their expectations, and upholding ourselves with integrity.

SCCE is the mechanic and technician's most trusted tools and equipment provider and advisor. We're here for all your needs.

**CUSTOMER-CENTRIC.
RELIABLE. LOYAL.**

WE'RE HERE TO SERVE YOU

In addition to incredible service, we're here to support you even after you've found the equipment you need. We provide maintenance and repair services to help keep your equipment in top shape. To learn more about our maintenance and repair service, call us at 855-999-SCCE.

AREAS WE SERVE



CALL US TODAY

**FOR THE BEST
EQUIPMENT &
SERVICE!**

(855) 999.SCCE

TABLE OF CONTENTS

Diagnosis & Calibration

Meridian Live Mapping System
Truscan Live Mapping System

Frame Repair

Mobile Systems
Evolution Systems
Koala Pulling Rack
Global Jig X-Pull
Super Rotax
Chief Phoenix Pulling Rack
Impulse Tilt

Frame Rack Accessories/ Toolboards

F.A.S.T Universal Adaptors
F.A.S.T Anchoring
Structural Holding Package
Deluxe Chain & Clamp
Auxiliary Pulling Packages

Welding

MI300T - Spot Welder
MI200T - Spot Welder
MULTIMIG 525 - Aluminum Welder
MULTIMIG 522 - Aluminum Welder
MULTIMIG 511 - Aluminum Welder
M240 - Synergic Mig Welder
MULTIMIG 822 - Three Phase MIG/
MAG Welder

Collision Center Tools

Lift King Light Duty
Lift King Heavy Duty
Lift King Combo
Vulcan Adhesive Debonding Unit
Heavy-Duty Riveting Tool
Rivet Gun

Dust Extractor 63L
5T Power Gun MotionLED &
Extension Arm
MotionLED Estimator Light
Fume Dog Portable Weld
Fume Extractor

Panel Repair

Flatliner Business System
ALU Slimliner
T-Hotbox (Steel)
Alu T-Hotbox (Aluminum)
MultiTook Workstation With M30

Plastic Welder

8203 Nitro-Fuzer Nitrogen Plastic
Welder

Thermody Technology

TD3 Pro

AC Equipment

MX1234
MX3030

Lifts

Forward Lift I10 Two Post Lift
Forward Lift EFP8
Forward Lift EFP9 Four Post Lift

Glue Pulling

Speedline Glue System
Speedline Accessory Kit
Speedline Eco System
Speedline Pro Station
Spare Glue Parts



DIAGNOSIS & CALIBRATION



CALL US TODAY

**FOR THE BEST
EQUIPMENT & SERVICE!**

(855) 999.SCCE



MERIDIAN™ Live Mapping™ system with GALILEO™ Scanner

Simultaneous and continuous measuring for 360° accuracy.



NOTHING ELSE IS A
CHIEF

PRECISION COLLISION REPAIRS START WITH
MERIDIAN™

CHIEF'S REVOLUTIONARY
LIVE MAPPING™ MEASURING SYSTEM

The foundation of any quality repair is accurate measuring and Chief is dedicated to providing the equipment you need to get every job done right. Your customers rely on you for accurate and timely repairs. So, CHIEF engineers have used the best technology to deliver a Live Mapping™ system that's more accurate, more robust, and easier to use than any before. The completely redesigned GALILEO™ multi-point laser scanner combined with our all new real time measuring interface makes this system the industry's most accurate. Simply place the scanner under the vehicle, select the vehicle you are working on, place the targets where shown and you are ready to go.



Get a real-time, Live-Mapping™ picture of every stage of the repair with MERIDIAN™. Hang targets once to get a multi-point, full picture measurement of the entire vehicle's damage for more accurate estimates. GALILEO™ locks in 45 pre-defined high-tech targets in real time. You can even measure out of level - so there's no need to tie up a frame rack - delivering precise reports faster, every time.

MERIDIAN™ means faster frame measuring, better estimates and precision repairs. Find any hidden damage during the scan, make more inclusive repair plans, increase profit and reduce repeat visits. This proprietary software identifies incorrect pull set ups before they are made, preventing additional damage and speeding up the total repair process. Our exclusive best-in-class specification repair data ensures that vehicle measurements are up-to-date. CHIEF's measuring products are OEM-certified and report the exact condition of the vehicle frame before, during and after repairs. This provides the evidence of the total vehicle damage and the high quality of the finished repairs.

PRODUCTS, TRAINING and UNRIVALED SUPPORT.



INTRODUCING GALILEO™

CHIEF's NEW self-leveling multi-point laser scanner - delivering on the money reports each time, every time.

The new GALILEO™ scanner's robust construction features aerospace materials and thermal resistant technology for increased durability and long life, even in harsh shop environments. Its single-hub design delivers a 360° view, minimizing target blockage allowing for an even faster setup and large field of view.



GALILEO FEATURES:

- Dual processors for fast real-time data processing
- Advanced optical components for accurate readings under any lighting
- Gorilla Glass® for added scratch protection
- Built-in calibration check allowing for easy technician verification

HIGH POWERED LASER

The scanner utilizes high powered laser technology which insures outstanding performance. Its state-of-the-art optical path increases measurement length up to 5M.

STABLE, OUT OF LEVEL MEASURING TECHNOLOGY

The geospatial control system makes necessary adjustments providing precise measurements no matter what direction the scanner is tilted. Out of level measuring allows the system to be moved from a 2-post lift for blueprinting to a frame rack or bench for structural repair in minutes without complicated set up. The revolving assembly's special design creates a stable perfect plane.

CONSISTENT AND RELIABLE: IT OUT PERFORMS ALL OTHERS!

High resolution geospatial design and micro-rotational technology create precise, consistent speed while measuring and calculating more simultaneous reference points than any other system. High tech targets eliminate distortion and read all frame types delivering deadly accurate frame measurements each time, every time. GALILEO™ can be left in place during repairs to monitor dimensional changes AS THEY OCCUR for faster, higher-quality repairs. There is never a need to recalibrate after every pull.

EASY-TO-USE OPERATION

1. Position the GALILEO™ scanner under the vehicle
2. Pull up detailed frame specifications for the vehicle being repaired
3. Hang the attachments and targets as instructed by MERIDIAN's tutorial
4. Watch as MERIDIAN shows you not only where the vehicle frame is out of alignment but also by how much and in what direction.

MERIDIAN™ STEEL CABINET WORKSTATION

Chief's computerized measuring tools are far and away the most sophisticated, yet simple to learn and operate system available in the industry today.

Lockable Steel Cabinet Workstation

- Durable, powder-coated frame structure
- Secure body scanner storage drawer
- Lockable - secure computer and printer cabinet storage
- Two rotating casters and two fixed casters
- Complete 110-volt or 220-volt system



Software

- Exclusive Chief software that is quick and easy to navigate
- On-screen photos of recommended targets and attachments, and where they should be placed
- Comparative SAI and Caster measurements
- Automatically calculates for removed components
- Incorporate your company logo into printout design
- Includes FREE interactive help and tutorial



Hole Attachments and Clips

- Magnetic hole attachments for fast and easy positioning
- Wide array of sizes from 10mm-25mm

Bolt Attachments and Clips

- Magnetic bolt attachments ranging from 10mm-25mm
- Threaded bolt attachments ranging from 10mm-32mm
- Metal clip attachments ranging from 10mm-35mm



Dual, High-Definition Flat Screen Monitors

The secondary web enabled monitor can run an estimating system or access your OEM repair procedures - technicians never have to leave the bay!



Targets

- 45 individual bar-coded reflective targets for simultaneous multiple-point measuring
- Sleek design and variable lengths allow for easy viewing of multiple targets...even on large pick-ups and SUVs
- Protective end caps help prevent damage for prolonged life



Target Extensions

Handy extensions attach to your existing targets, making them longer and allowing you to measure around underbody obstructions.

Part #798440

Laser Body Scanner Storage

Easy-to-reach drawer securely stores scanner protecting it when not in use.





Real-Time Measuring with Upper Body Bar Package

Measure the vehicle's strut towers and frame at the same time during pulls for higher-quality and faster repairs.

- Measure SAI and Caster
- Strut towers and fender bolts
- Generate comparison measurements for roof when optional extensions are used
- Generate comparison measurements for deck lid openings
- Generate comparison suspension angles when ball joints and strut towers are being measured

Part #788013D



Computer

- Windows 10 Professional Edition / Required
- Heavy-duty CPU with Extreme Graphics, DVD player and 6-Channel high-output audio system
- Hyper-threading feature allows multiple programs to run simultaneously without slowing either program
- Stored safely in cabinet bottom
- Integrated Wi-Fi and BLUETOOTH functions

Color Printer

- High-speed, high-resolution color printer is stored in cabinet bottom

Customize your measuring system into a comprehensive vehicle repair center. Optional innovative software and accessories quickly measure and document the dimensional condition of frames, body openings, and upper body openings. Create print documentation for customers and insurance companies of the high quality of your repairs.

AUTOSCAN

Profit-Boosting Software

Chief's AutoScan[®] and Estimator Pro-V[®] software, which provide more revenue generating opportunities that customers will appreciate and that will save considerable time during the front-end inspection and estimating process.

Precision Specifications

MERIDIAN uses Chief Thunderbolt specs, which feature frame data for thousands of domestic and import cars and trucks from the present back to 1994, as well as Upper Body Opening data including doors, windows, hatches and strut towers. Chief specs have more vehicles than anyone else, and measures every vehicle personally with frame anchored and the suspension unloaded to provide you with "real world" accuracy other specs can't match.



Intelli-Tape™

This optional system allows you to quickly measure body openings and point-to-point distances. This data is wirelessly transmitted to your system, instantly populating the correct fields and enabling you to produce printed color documentation of your findings.

Part #787071



E-Access[®] On-Line Tech Support

E-Access[®] allows you to contact Chief's Tech Support team whenever you need assistance. Our experienced tech's can help you work through tough repair questions and can even take over your system, if asked to, to help you make sure the repairs are right the first time.



Rear Wheel Tracking Gauge

Check and verify rear wheel tracking, offset, toe and length from body zero line. Measurements are automatically displayed on your monitor screen, and helps find and correct alignment issues before reassembly.

Part #702210



Absolute Proof

Reinforce trust between you and insurance providers and generate more insurance-related business for your shop. Final inspection reports prove repairs were needed and returned the vehicle to pre-collision condition. This proof of high-quality repairs generates more repeat and referral business.

CHIEF TRUSCAN

LIVE MAPPING™ MEASURING SYSTEM
FAST SET UP. EASY TO OPERATE.

ACCURATE AND AFFORDABLE

All the capabilities you need, at a price that will make you wonder why you've waited so long. Spend less time training and more time making money with this accurate and affordable system. TRUSCAN™ integrates the precision of the NEW GALILEO™ laser scanner with LIVE computerized measuring for unmatched accuracy in collision repair and analysis before, during and after repairs.

MEASURE LIVE DURING REPAIR

GALILEO™ can be left in place during LIVE repairs continuously monitoring entire vehicle during changes AS THEY OCCUR for increased speed and accuracy. No more pulling and measuring, then pulling again. This laser technology is never affected by outside influences like noise, air movement or light. The result is the most precise and accurate measuring available.

INDIVIDUALLY CODED TARGETS

Chief targets use time tested scan technology and eliminate any distortion caused if the target is slightly angled. Recessed faces help prevent damage for prolonged life.

PRECISION SPECS

TRUSCAN™ uses OEM-certified Thunderbolt™ specs, which feature frame data for thousands of domestic and import cars and trucks from present back to 1994, as well as Upper Body Opening data including doors, windows, hatches and strut towers. TRUSCAN's final report illustrates needed work was completed properly, proves vehicle has been returned to pre-collision condition and reinforces the trust between your shop and the insurance provider.

TRUSCAN EQUIPMENT PACKAGE

Steel Cabinet Workstation
Durable, powder-coated baked finish
High-definition flat-screen monitor
Two rotating casters and fixed casters
Complete 110-volt or 220-volt system

Computer
Windows® 10 Professional Edition
Printer
High-resolution color printer

Body Scanner With Frame Tray
Compact design reduces target blockage and improves line-of-sight, allowing more reference points to be measured

Targets
32 individual bar-coded reflective targets for simultaneous multiple-point measuring
Recessed faces for protection

Bolt Attachments / Clips
Metal style attachments
Clip-on bolt heads ranging in size from 10mm to 35mm
Hole Attachments / Clips
58 aluminum snap-in attachments ranging in size from 10mm to 32mm
Side hole clips ranging in size from 23mm to 35mm

Software
One-touch movements
X-measurements can be made with one mouse click
On-screen photos of attachment placement
Comparative SAI and caster measurements
Calculates for removed components
Color reports to show measurements before, during and after repairs
Your company logo can be incorporated into documents
Interactive help and tutorial

Literature
Users Manual, Parts Manual, Basic Training Manual
Manuals for computer, printer and Microsoft® Windows
Available on CD



Scanner shown on cabinet shell

TRUSCAN OPTIONAL ACCESSORIES

Upper Body Bar with Stabilizer

Measure the vehicle roof, trunk, or even two strut towers at once. Included stabilizer eliminates out-of-level/sway issues for accurate readings every time.

Part No. 788452



Vertical Scale Assembly

Attaches to the Upper Body Bar to allow measurement of vehicles with tall strut and/or underhood areas.

Part No. 797786



Target Weight Assembly

Attach directly to the bottom of your targets to eliminate target sway.

Part No. 792024



Drawer 4 Targets

Allows measurements on the vehicle frame — even the biggest pickups and SUVs.

Part No. 799535



Target Extensions

Handy extensions attach to your existing targets, making them longer and allowing you to measure around underbody obstructions.

Part No. 798440



Vertical Surface Attachment

Allows you to make comparative vertical measurements on upper body openings like doors and windows.

Part No. 799811



Intelli-Tape

Quickly and accurately record and transmit upper body and point-to-point measurements. Measures underhood points, doors, windows, hatches, trunks and much more.

Part No. 787071



COMPUTERIZED MEASURING

FRAME MACHINES

VEHICLE DATA

ALUMINUM REPAIR

WELDING

FIXTURE and HOLDING

BODY SHOP TOOLS

WHEEL SERVICE



COLLISION REPAIR TOOLS

Chief offers the most extensive line of collision repair equipment. Combine that with our vehicle specifications and CHIEF University's training curriculum - why would you go anywhere else?

We offer everything you need for today's repairs and tomorrow's.



FRAME REPAIR



CALL US TODAY

**FOR THE BEST
EQUIPMENT & SERVICE!**

(855) 999.SCCE

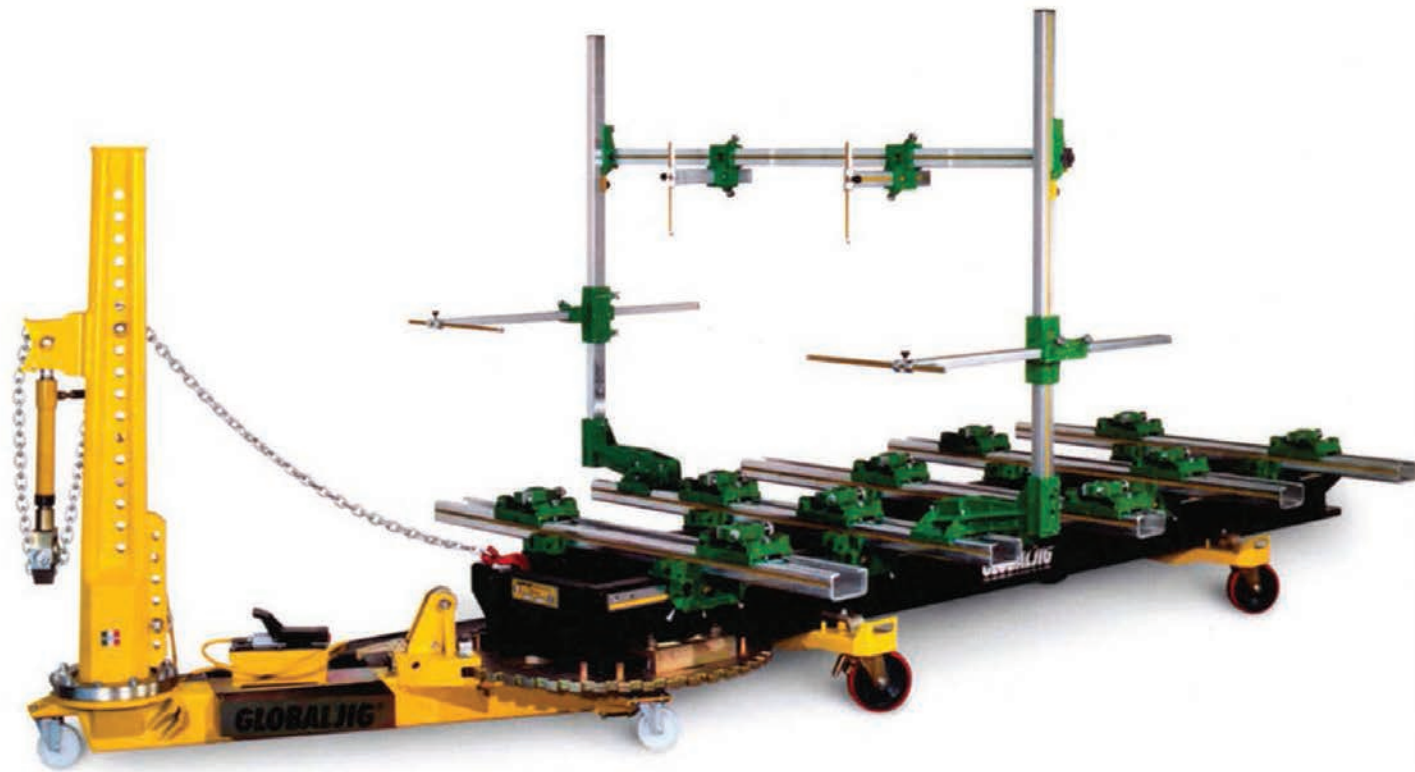

SYSTEM

A reference point for the OEM

The Globaljig System mobile bench has long been considered the top of its category. It is the equipment that has changed the perceptions about mobile benches. Equipped with the Globaljig Universal Fixturing System that allows centering of the vehicle after it is fixed to the jigs it can save up to 75% of the time required to load a vehicle.



The standard McPherson overhead measuring bridge is extremely precise in the control of upper suspension points and for comparison of points on the side and upper body.

Mobile 5.0

Pictured Above

Globaljig System,
Suitable for repair of any vehicle

GLOBALJIG PRESENTED BY **TECHIEF**

Universal Fixtures



Parts of the Universal Fixture System are easy to locate in the storage cabinet, making fixturing any vehicle efficient

The Monocube



The patented monocube and microfusion steel brackets with one bolt fixing save 75% on jig mounting times.

Vector Pulling Tower



The Vector Pulling Tower allows 360° of pulling or pushing access. to carry out any pull necessary.

GLOBALJIG PRESENTED BY **TECHIEF**



Evolution Jig Bench is the economical solution for those repairs where a mini-bench is not enough. With 5 crossbeams, loading ramp package and the D157 Fixture Set, it has all the hardware needed for the 8 point holding that OEMs require when a new design vehicle is structurally straightened.

Precision engineering and full attention to detail are a recognized standard of Globaljig quality-making Globaljig the obvious choice for the modern collision repair shop.



Options include the adjustable universal sill clamps with sliding base blocks of the Globaljig Universal Jig System.



The McPherson overhead and side measuring bridge (E121) can also be used on Koala.

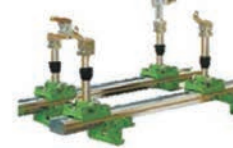

Add two or three crossbeams with a small set of fixtures then you have 8 to 10 point holding.



D190 Down Pull mounts to crossmembers.



With threaded rods and ratcheting action, the E131 push/pull jig can easily raise or lower any jig point.

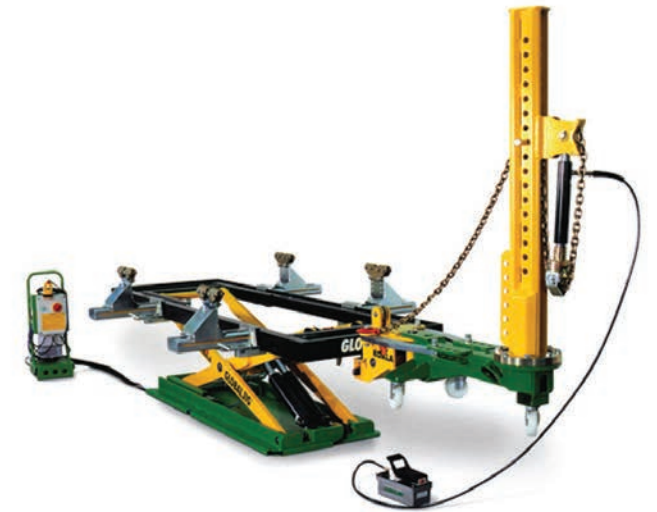

SHARED ACCESSORIES

Evolution JIG BENCH

GLOBALJIG NORTH AMERICA, L.L.C.

Evolution

THE ECONOMICAL SOLUTION TO 8 POINT HOLDING REQUIREMENTS

TECHNICAL DATA

LENGTH	14.75 ft.
LIFT CAPACITY	6,600 lbs.
MAX HEIGHT	4.5 ft.

KOALA THE PERFECT CHOICE FOR "EFFICIENCY"

GLOBALJIG PRESENTED BY **ECHEIF**

KOALA

THE PERFECT CHOICE FOR "EFFICIENCY"

With the optional cover plate in place and the bench pit mounted, Koala is flush to the floor when fully lowered.

The Articulated Pulling Tower with GLOBALJIG "Vector" vertical post ensures the perfect chain angle for every pull.

Evolution

Evolution is a 4.5m (14.75 ft.) bench that's ideal to replace old drive on racks taking up a smaller footprint without sacrificing repair capabilities.

The modern vehicle database, and datasheets in 2D and 3D formats, allows the fixturing of vehicles with mechanical parts either in or out. Quickly fixture any vehicle for precise results and added security in the quality of the repair.

The Evolution Jig Bench can be easily upgraded to a full Globaljig Fixture System with storage cabinet and McPherson overhead and side body measuring.

KOALA

Koala is easy on the budget and big on profits!

The small straightening bench with great versatility and potential. Suitable for all situations. Compact and out of the way when not in use due to the 6" height when fully lowered. Economical enough to put in every technician's stall, as multiple benches can share pulling post and other common tools.

Use Koala as a work bay lift for blueprinting, vehicle tear-down and reassembly, or metal straightening.

Put the vehicle in sill clamps, attach the 10 ton post, and Koala can handle 90% of the structural work that comes through your shop.

Add crossbeams with jigs and the Koala can handle even the hardest hit unbody vehicles.

POSITIONING
Positioning of the vehicle without ramps. At only 6" off the floor Koala is a true drive-over bench.

LIFTING
With the lifting pads used as an install lift.

RESTING
Lower into the wheel stands, equipped with casters, and mount the sill clamps.

TIGHTENING
Tighten the sill clamps and you're ready to attach the post and pull.

TECHNOLOGY AND INNOVATION LOOKING INTO THE FUTURE

SUITABLE FOR NEW 8 POINT HOLDING REPAIR CONCEPTS

TILTS FOR EASY LOADING OF THE VEHICLE

PULLING TOWERS ON-BOARD

MONOCUBE JIG SYSTEM

This bench tilts allowing easier loading of the vehicle when driving up or winching onto the ramps. Vehicles can be loaded into sill clamps in as little as 15 minutes and thanks to the sliding crossbeams and base blocks, fully fixturing is also a quick and efficient process.

Pulling towers remain attached to the bench and effortlessly glide 360 degrees around the bench. The "Vector" design of the towers means chain angles are always correct for every pull.

The internationally patented Monocube Jig System makes for faster one-bolt setup with superior holding capabilities.

THE PERFECT CHOICE FOR "EFFICIENCY"

CLAMPS ATTACHMENT OF POST MAXIMUM HEIGHT BASIC LIFT PACKAGE / STANDARD COMPOSITION TECHNICAL DATA

Sill clamps with extension plates allow increased space between the bench and vehicle, allowing room for any type of measuring system on the market.

The mounting of the pull post is quick and simple and it can be mounted anywhere 360 degrees around the Koala frame.

Raise 5,500 lbs to a working height of 5 feet 3 inches. Koala lets you choose the most ergonomic working height from just a few inches to almost 5 and a half feet.

GLOBALJIG

LENGTH	10 ft
WIDTH	3 ft
MINIMUM HEIGHT	6 inches
MAXIMUM HEIGHT	5 ft. 3 in.
LIFTING CAPACITY	5,500 lbs
WEIGHT	3,241 lbs

GLOBALJIG

NEW



The adjustable brackets are always mounted on the frame, on which you use the sliding rubber pads adjustable in height manually, even when you are positioning the car, and those stackable are used to lift vehicles with higher bodies.

With the wide and fast height adjustment of the sill clamps it is possible to fix and lock any type of vehicle that has the edges of the crests from a minimum 89 mm to a maximum of 308 mm and it is therefore possible to apply and use on the bench any type of system computerized electronic measurement.

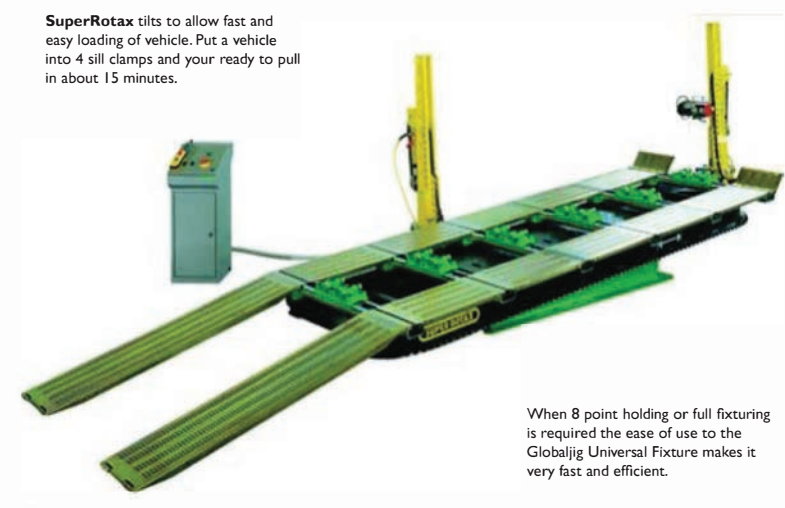

SuperRotax tilts to allow fast and easy loading of vehicle. Put a vehicle into 4 sill clamps and your ready to pull in about 15 minutes.

When 8 point holding or full fixturing is required the ease of use to the Globaljig Universal Fixture makes it very fast and efficient.



Positioning of the car without the aid of wheel runner for alignment

The modern choice

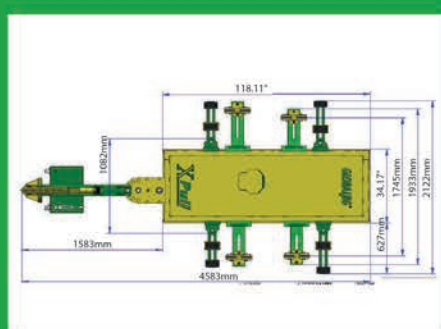

TECHNICAL DATA:
 Length frame : 118.11"
 Width frame : 34.17"
 Max height on frame : .049"
 Minimum height : 3.93"
 Lifting capacity : 6.614 lbs
 Power:
 Rated Voltage : 380V
 Rated frequency : 50 Hz

Lift and Repair quickly



SUPER ROTAX "ABSOLUTE PERFECTION"

GLOBALJIG PRESENTED BY **ACHIEF**

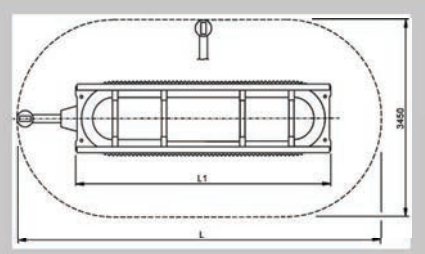

FOOTPRINT
 L L
 5m 25.4 ft Super Rotax is available
 6m 28.7 ft in 5m (16.4 ft) length or
 6m (19.7 ft) length

GLOBALJIG PRESENTED BY **ACHIEF**



"ABSOLUTE PERFECTION"

X-Pull

The new X-PULL is a lift bench, it is very compact and allows great performance for many quick repair operations. The positioning of the vehicle is fast and practical, you lift the car on the rubber pads of the adjustable arms, and without the aid of wheel runner for alignment, you can mount the adjustable sill clamps to raise the vehicle from the support on the rubber pads. X-PULL is particularly suitable for "fast repair" today so current and necessary.

"Minimum investment, great use"



Shooting positions with double rotation, vertical and horizontal to find the right direction, and it is equipped with a practical tool drawer and a hydraulic set.



The pull arm is powerful and removable, it is applicable at any point of the frame, with the special key supplied you get a quick and secure tightening, to pull and straighten cars in any 360° direction.

GLOBALJIG



The Super Rotax system comes standard with the full Globaljig Universal Jig (12 pts) with storage cart, the McPherson Overhead Measuring Bridge, loading ramps, loading stands, winch and one pulling tower fitted with accessories.



COMPLETE SYSTEM

UNSURPASSED EVEN IN HEIGHT - A FULL 5.75 FT

Certified material quality - Technology - Design expertise puts Globaljig products at the forefront of the auto repair industry

The frame is mounted on a scissor lifter with two rams, controlled by an electro-hydraulic power unit with manual push-button panel, and a mechanical safety system with double harpoons, which works on anti-fall lock seats obtained with laser cuts on the base on the lifter.

The minimum height of its frame allows it to position any type of car and also be used as a lift for frequent operations such as assembly, disassembly of damaged parts, welding to replace parts of the structure and polishing of the car at preferred height.

The manual adjustment of the four rubber pads and those overlapping on the adjustable arms, allow you to adapt to the widths of the vehicles and to be adjustable in height until the contact of the floor under the car.

The adjustment and the choice of the height of the four sill clamps is made with the help of an air gun that speeds up the fixing operations of the car and a quick disassembly at the end of the repair operations.



MONOCUBE JIG	PULLING TOWER	LOCKING CROSSBEAMS	ARTICULATED PULLING TOWER	LIFT	FULL FRAME HOLDING
The patented Monocube Jig block saves 75% of the time required to install the jigs to the vehicle. Machined from one solid piece they have unsurpassed strength and a lifetime warranty.	The 10 ton vector pulling towers glide effortlessly 360 degrees around the bench and can even be used to push from.	The crossbeams lock and unlock with a few turns of a bolt. A vehicle can be easily moved before and after on the bench even when it is tied to the clamps and fixtures	The optional articulated pulling tower when paired with the stand tower, allows both towers to be placed near each other for two simultaneous and close pulls.	High performance scissor lift can raise 7,700 lbs to adjustable working heights of up to 5 ft. 9 in. and has a full mechanical safety lock.	Optional full frame holding clamps can be used for truck and SUV frame repairs, alone or with the added benefit of fixtures also for the ultimate holding capabilities.

IT'S TIME TO
PUT DAMAGE IN
ITS PLACE.



CHIEF **PHOENIX**
POWERED BY GOLIATH™

CHIEF's newest frame rack provides the size and flexibility to profitably repair today's cars and trucks.

CHIEF
PHOENIX™
PULLING RACK

Designed and engineered with industry-leading features you've come to expect from **CHIEF**, the **NEW PHOENIX™ Frame Rack** offers the size, capacity and flexibility for your shop to profitably repair the vehicles of today!



- FEATURES**
- 12,000 lbs. Lifting Capacity
 - Self-Leveling Deck
 - 20' and 22' Rack Lengths
 - Variable Height Technology with Six Working Heights from 19"- 40"
 - Powder Coated Components

**PUT DAMAGE IN ITS PLACE
AND PROFIT IN YOUR SHOP!**

**FEATURING PORT-A-FRAME!
CHIEF'S NEW INNOVATIVE HEAVY-DUTY LIFTING SYSTEM**



- 12,000. lifting capacity with a 22' by 92" deck supports repairs from cars to large delivery vans
- Variable working heights for ergonomic vehicle access

**FAST & EFFICIENT
TOWER CONNECTION!**



- Multiple in-deck quick connectors plug in at 4 deck corners to adjust to different angles for multiple pulling
- Hoses with quick connectors store inside frame deck

**EXCLUSIVE! VARIABLE HEIGHT RACK
WITH INTERNAL PUMP ALLOWS FOR MORE WORKSPACE**



- Unique hydraulic pump lifting system is centered in middle of rack
- Electric-over-hydraulic provides for smoother, quieter operations

**EASY-TO-USE CONTROLS
IN THE PALM OF YOUR HAND!**



- All height and pull functions are controlled from a hand-held pendant control
- No hassles with foot pumps or changing out lines

OPTIONAL RAMP LENGTHS FOR FAST, EASY LOADING!



- Removable for 360° tower access to free up needed bay space when lifted from the deck
- Redesigned hinged ramps are adjustable to compensate for uneven floors.
- Optional lengths allow for quick loading of low-profile sports cars to large trucks

Tall towers with 10 tons of power at the hook allows techs to easily perform multiple simultaneous pulls. Gang towers anywhere for 360° pulling around the deck perimeter for absolute control over the repair process.

High-performance tapered tower roller bearings raise off channel when tower is locked and bear no weight during pulls for years of maintenance-free operation. Four bearings per tower.

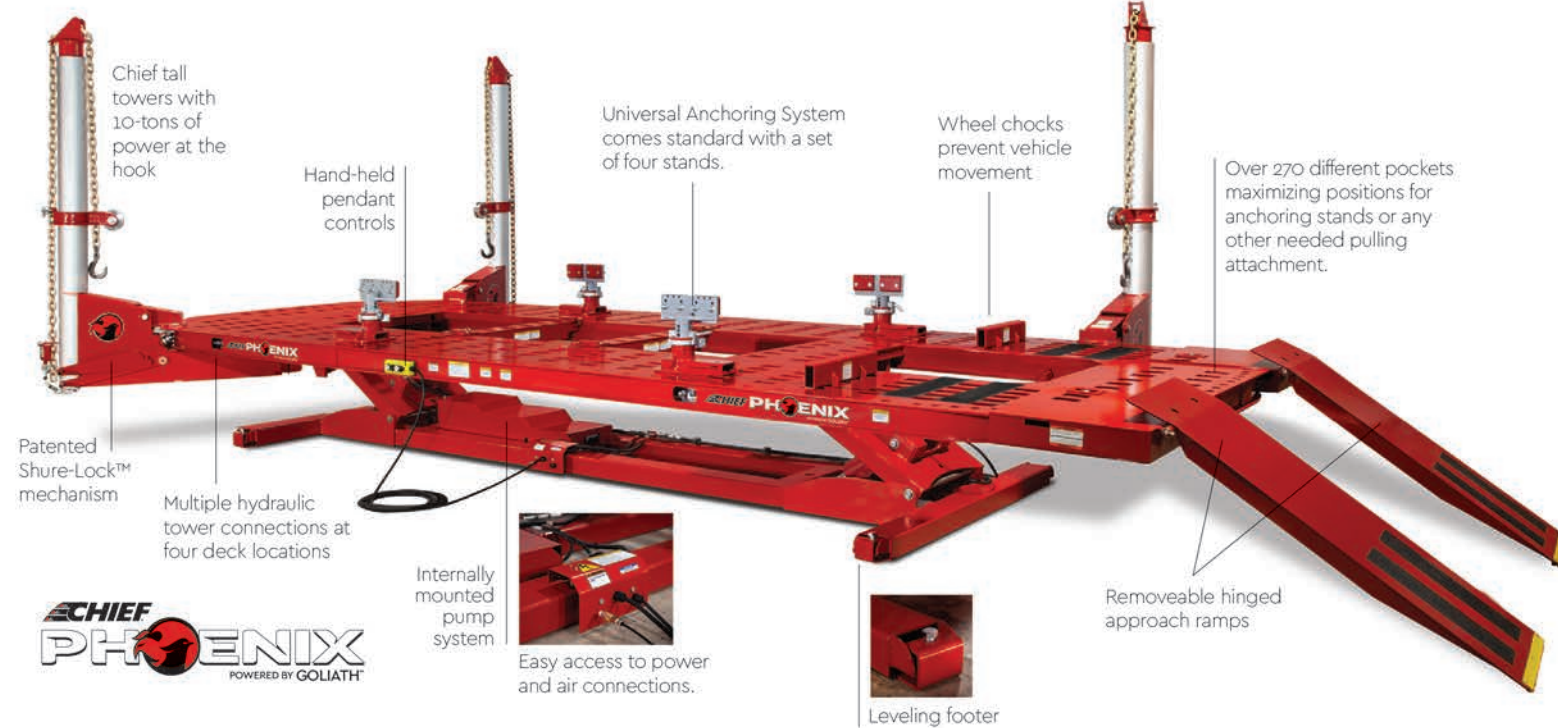

Chief tall towers with 10-tons of power at the hook

Hand-held pendant controls

Universal Anchoring System comes standard with a set of four stands.

Wheel chocks prevent vehicle movement

Over 270 different pockets maximizing positions for anchoring stands or any other needed pulling attachment.

Patented Sure-Lock™ mechanism

Multiple hydraulic tower connections at four deck locations

Internally mounted pump system

Easy access to power and air connections.

Leveling footer

Removeable hinged approach ramps



Universal Anchoring System
Comes standard with a set of four stands. Adjust and secure most vehicles for precise, four-point positioning.

The Uni-Clamp can be retrofitted onto existing universal anchoring stands and is designed to work with all Chief specialty anchoring products.

Chief's Trademark Telescoping Tower Heads:

- Features rugged 1/2" chains proof tested to 14 tons
- Adjustable tower collars allow positioning on towers for precise pulls

Tower rams with 10" stroke provide 10-tons of pulling power.

Tower collars are designed to drop down if a clamp comes off vehicle to keep technicians safe.

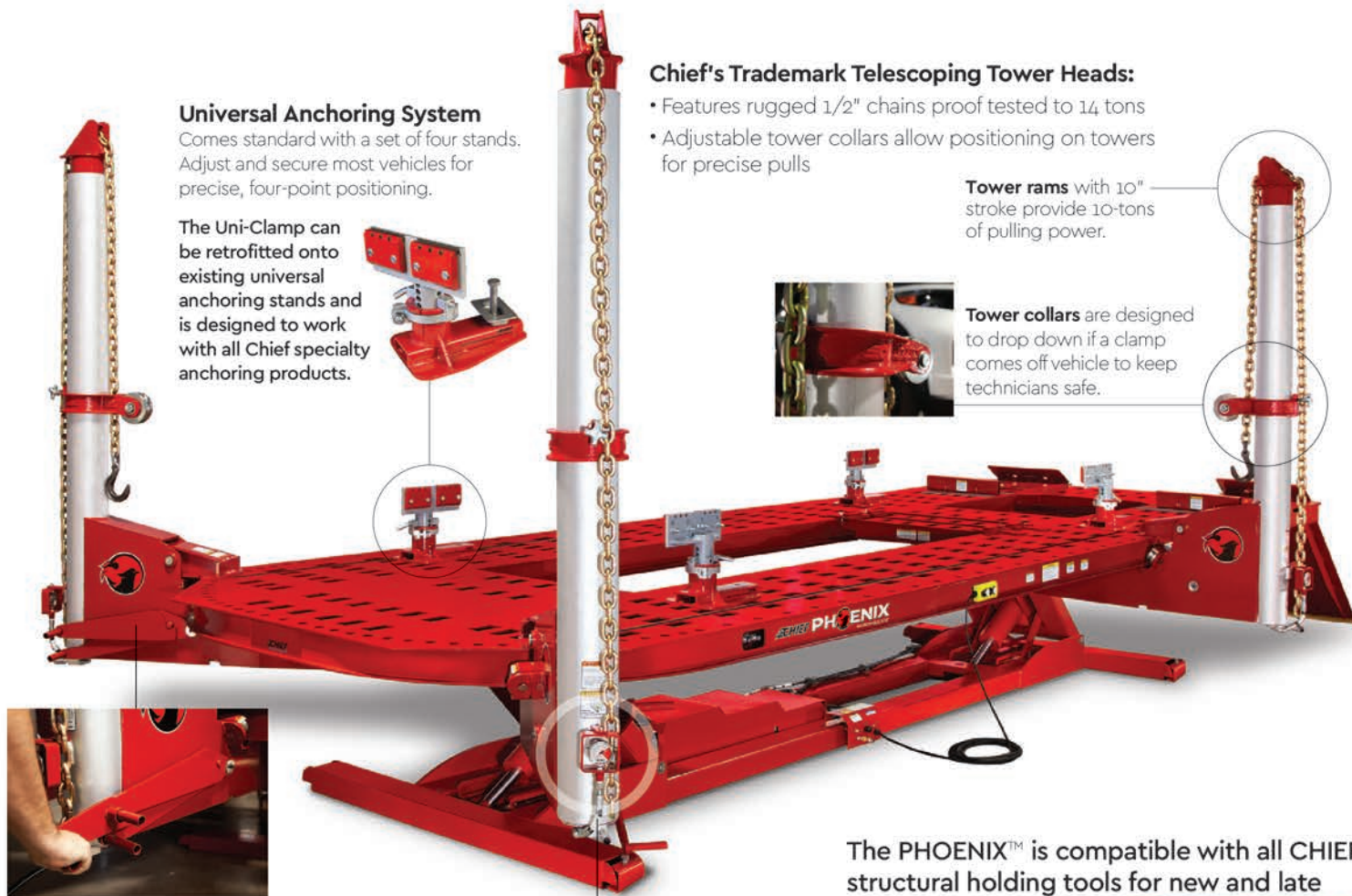

Patented Sure-Lock® mechanism

pins and secures towers with one movement for added speed and safety. Locks are designed to relieve pressure off the bearings while doing pulls, increasing durability of the rack.

Handle extensions make locking and unlocking towers easy.

Pressure gauges at each tower monitor and control different pressures during multiple pulling.

Valves allow towers to operate separately or simultaneously and keep clutter to a minimum.



The PHOENIX™ is compatible with all CHIEF® structural holding tools for new and late model vehicles.

Two re-positionable cross members add up to 280 positions for anchoring vehicle downpulls.

The rack surface features 170 tie-down openings for anchoring stands, or any other attachments needed for multiple pulling requirements.



SPECIFICATIONS / 22' RACK

Maximum Length with ramps	28' - 6"
Maximum Width (Footprint)	7' - 8"
Maximum Height	9' - 4"
Height with tower rams extended	8' - 2"
Clearance required on all sides	2' - 2"
Tie-Down Openings	172
- with optional cross-member	280
Tower Materials	5/16" and 3/8" High-Strength Steel
Deck Plate Strength	50,000 PSI Yield A-572 Steel Plating
Power / Single Phase	120 VAC / 20 Amp
Air Supply / Power Required	100 PSI
Weight: 2 Tower / 3 Tower	7,100 lbs. / 7,750 lbs.

Chief Collision Technology® reserves the right to alter product specifications and/or package components without notice.

Optional Accessories Contact factory for additional details and options.

Chief Tool Board Packages feature the most innovative tools for repair. Pulling accessories are available in various configurations, offering maximum versatility to keep pace with evolving automotive design. Make precise pulls on hundreds of unitized and conventional frame models while minimizing structural distortion.

Deluxe Chain & Clamping Accessory Package

When you need to do the job right. Wall Mount or Cart Mount option



Visit www.chieftechology.com for additional information and a parts breakdown.



Impulse Tilt Tilt to Load Machine

#450010 / 18' with Two Towers
#450285 / 18' with Three Towers
#450286 / 18' with Four Towers

Increase your shop's productivity and profitability with the Chief ImpulseTilt

The Impulse comes with two 10 ton towers, and additional towers can be added for increased pulling capabilities. The tilting platform and drive-on interchangeable ramps keep loading and unloading faster and safer. Impulse also comes with Chief's Universal Anchoring System with eight working heights, so techs can adjust it to most vehicles for precise four-point positioning.



Drive-on ramps and a tilting platform

Features

- Foot pump hydraulic
- 10 ton high pressure tower
- 6,000 lbs. of lifting capacity
- Low pressure systems offer more power and tighter control for faster, higher quality repair
- True 360 degree pulling



SPECIFICATIONS	IMPULSE TILT
Feature	18-Foot Standard
Deck length	18' (5490mm)
Deck Width	6'8" (2030mm)
Working Height	26 1/2" (673mm)
Max. Length (drive-on ramps included)	19' 8" (5994mm)
Max. Length (towers extended to both ends)	22' (6705mm)
Max. Width (Footprint)	6' 8" (2032mm)
Max. Height	7' 6" (2286mm)
Height (with tower rams extended up)	8'2" (2489mm)
Lift Capacity	6,000 lbs. (2,721 kg)
Pulling Force Per Tower	10-Ton
Radius of Pull	360 degrees
Controls	Air-Over-Hydraulic Foot Pump
Clearance (recommended on all sides)	2' 2" (660mm)
Tie-Down Openings	172
Tie-Down Openings (with optional cross-member)	178
Power Required	100 PSI Air Supply (7.0 Bar)



FRAME RACK ACCESSORIES/ TOOLBOARDS



CALL US TODAY

**FOR THE BEST
EQUIPMENT & SERVICE!**

(855) 999.SCCE

F.A.S.T. to Universal adapters



This adapter allows the use of F.A.S.T. accessories with Universal base plates

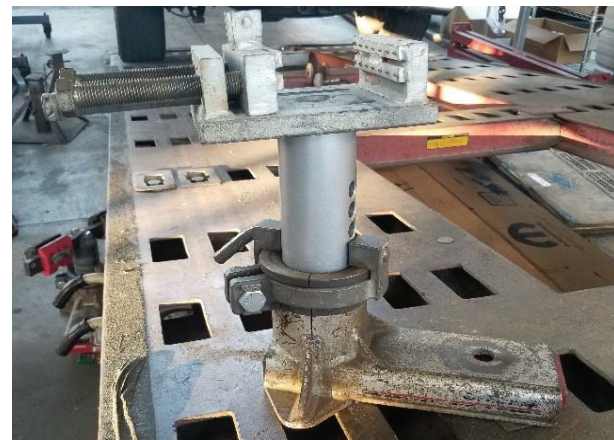

Standard adapter kit on left.
<
Standard deluxe kit on right. >



Use of these adapters along with the F.A.S.T accessories and Universal base stands allow a technician to quickly set up a vehicle for measuring. The rail saddle plates are also useful when used for measuring and they are wide enough to be used on the wider frames on some vehicles.
“Not recommended for use in pulling procedures”
Special thanks to the team at Selman Collision Center in Orange California and Chris Stoffel at Southern California Collision Equipment for their input in the development of these products.



Chief Tool Board Packages feature the most innovative tools for repair of today's vehicles. These pulling accessories are available in various configurations, offering maximum versatility to keep pace with the evolution of automotive design.

Structural Holding Package 300001

Part #128 - 300001 Weight: 555 lbs. (252 kg)

The Structural Holding Package is designed to give additional holding to newer vehicles manufactured with large amounts of High Strength and Ultra High Strength steels and additional Aluminum structures.

Structural holding allows a technician to apply additional holds, spreading out the amount of pressure at each hold location reducing the chance of additional damage during repairs. This holding is necessary to hold a part being replaced in the correct location for welding and bonding.

This system will fit any Chief or Chief style machines with rectangle holes on top of the deck. This concept allows a shop that has an older machine to be equipped with the latest technology in holding systems that will assist in repairs on the newest vehicles.

This Structural Holding Package is conveniently mounted on a tool board that outlines each component making it simple to identify where the part goes; all of this affixed to an easy-to-roll cart designed for the technician's convenience and a clean looking shop.

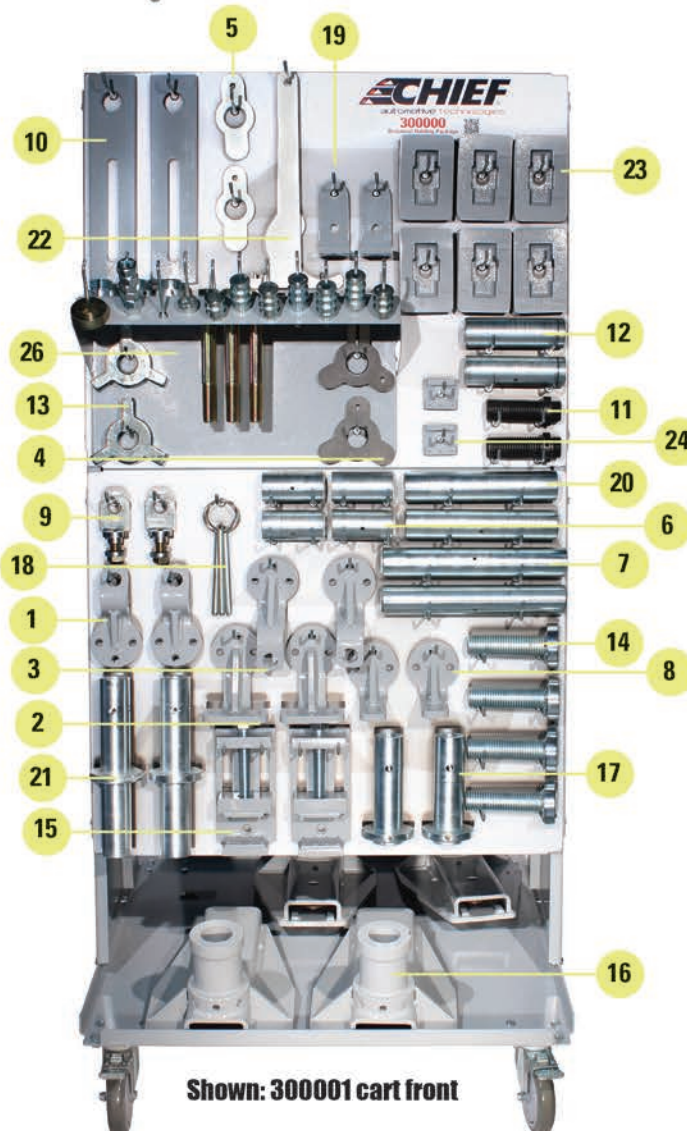

No.	Part No.	Qty.	Description
1	502000	2	Vertical Fixture Short
2	502005	2	Horizontal Fixture Large
3	502008	2	Vertical Fixture Tall
4	502014	2	Wing Nut, Parts Holding - LH
5	502015	4	Wing Nut, Parts Holding - RH
6	502016	4	4" Extension Tub
7	502017	2	12" Extension Tub
8	502019	2	Tall Horizontal Fixture
9	502026	2	Angle Adaptor Clamp Ass'y
10	502031	2	Base Plate
11	502033	2	Adapter, Parts Holding Lower
12	502034	2	Center Tub Parts Holding Turn Buckle
13	502038	2	Rigging Nut
14	502039	4	Structural Holding Adapter Ass'y
15	502042	2	Structural Vise Ass'y
16	502047	4	Structural Parts Holding Base
17	502055	2	Short Tub Base Stand Ass'y
18	502058	4	Release Pin Ass'y
19	502060	2	Wrist Block
20	502061	2	10" Extension Tub
21	502063	2	Tall Tube Base Stand Ass'y
22	502067	1	Spanner Wrench Ass'y
22	502069	1	Spanner Wrench Ass'y
23	607371	6	Fastener Plate, UAS
24	638133	2	Jaw Clamp Ass'y
25	611311Y	2	Parts Holding Arm (on cart back)
26	502062	1	Bolt Tray, Structural Holding

Shown: 300001 cart front

Designed and distributed by AH&SI. Home of Ajon Mobility and A Rack Adaptors.

Prototypes shown in illustrations, finished product has 6 locator positions for finer height adjustments.



Chief Tool Board Packages feature the most innovative tools for repair of today's vehicles. These pulling accessories are available in various configurations, offering maximum versatility to keep pace with the evolution of automotive design.

Structural Holding Package 300001

Part #128 - 300001 Weight: 555 lbs. (252 kg)



Shown: 300001 cart back

The **parts holding arm** allows for quick and easy set-up giving the technician the ability to adjust in all directions from any hole on the deck.

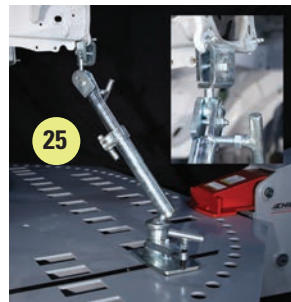

Part #611311Y / Parts Holding Arm

Vertical fixtures can mount to locations such as the suspension mounting areas creating a very strong hold for structural repairs.



The **large horizontal fixture** allows the ability to hold and control the end of a rail or structure for alignment or replacement of that component.



The **structural holding package** can be used to make **eight point holding** where needed with suspension in or out.



The system can be used for **Unitized and Full Frame vehicles** utilizing the vise clamp to hold full frame rails.

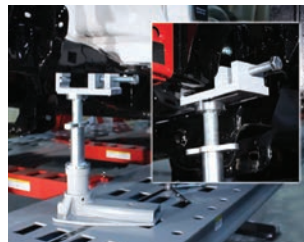

The **F150 Tool Board** allows three ways to create holds for repairs:

The **Rigid Cab Mounts** are used to replace the rubber factory cab mounts during structural repairs.

Additional holds can be made when using the **90° Angle Pinch-Weld Jaws** that mount to the rocker flange in conjunction with the FAST Anchoring system.

A third method of holding is using the **Running Board Fixture** in conjunction with the base and fixture extensions within this parts package.

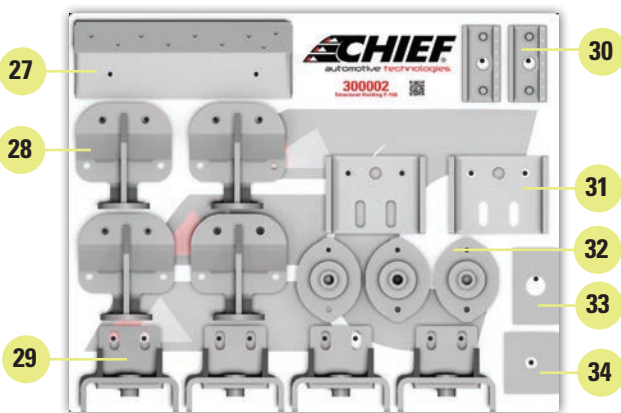

No.	Part No.	Qty.	Description
27	502070	1	Bolt Tray, Structural Holding, F150
28	640114	4	F150 Running Board Bracket Ass'y
29	640004	4	Weldment, Pinch-weld Base, F150
30	498110	4	Pinch Jaw with Nails Complete
31	640076	4	Formed Vertical Clamp, F150
32	640120	6	Weldment, Cab Mount, F150
33	640100	6	Support Plate, Cab Mount, F150
34	682953	4	Plate, EZ-Liner Tie Bolt

For additional kits for these brands and more, contact us!



Chief Tool Board Packages feature the most innovative tools for repair of today's vehicles. These pulling accessories are available in various configurations, offering maximum versatility to keep pace with the evolution of automotive design.

Structural Holding Package 300021

Part #300021 Weight: 555 lbs. (252 kg)

Structural Parts Holding Base

Equip and update your shop with the latest technology in holding systems and repair the newest vehicles on the market!

This holding system is designed to fit many non-Chief style machines without standard rectangle holes on top of the deck.

The Structural Holding Package is designed to give additional holding to newer vehicles manufactured with large amounts of High Strength and Ultra High Strength steels and additional Aluminum structures.

Apply additional holds, spread out the amount of pressure at each hold location and reduce the chance of additional damage during repairs.

Chief's USH Clamp System can be used on a wide variety of Deck systems. Operators must have the correct size mounts.

Anchoring with sliding base

IMPORTANT:

Usage of this system is dependent upon mainframe design and tread width.

Position clamp mount on top of machine's treadway at corners of vehicle's section. Clamp mount must engage inner edge of treadway and outer clamp must engage outer edge of treadway.

Slide USH Sliding Base into clamp mount and position at desired location. Slide Structural Holding System tube into stand and build to desired height.

After locating the replacement part to the vehicle, secure clamp mounts to the treadway and sliding base within clamp mounts. The clamp mount bolts must be tightened to 80 foot pounds torque (maximum). The clamp mount hex socket set screws must be tightened - snug only.

NOTE: Always inspect clamping locations for fuel lines, brake lines, or other items which may interfere with attachments on vehicle.

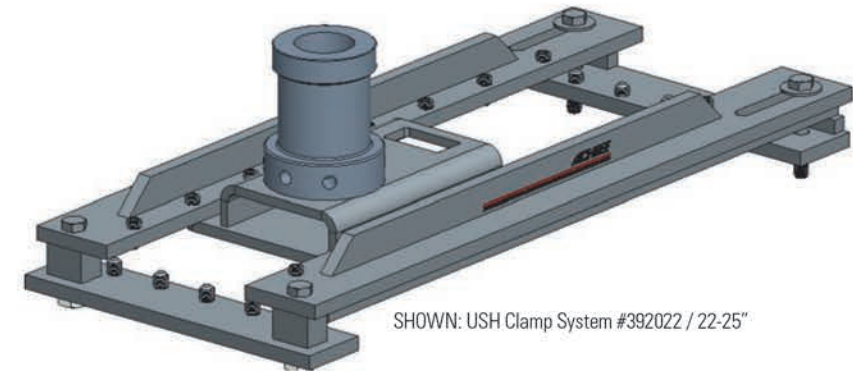

SHOWN: USH Clamp System #392022 / 22-25"

MODELS / AVAILABLE LENGTHS*

#392020 / 16-19" USH Clamp System	#392023 / 25-28" USH Clamp System
#392021 / 19-22" USH Clamp System	#392024 / 28-31" USH Clamp System
#392022 / 22-25" USH Clamp System	#392025 / 31-34" USH Clamp System

*Tool kit 300021 is to be used with one of the model numbers listed above - kit does not include the four bases which are sold separately.

Anchoring with thru holes in deck

NOTE: Long hardware bolts, tie down plate, and fastening bar will only be required when using with thru holes in deck, not with clamping systems.

Place USH Sliding Base Assm on flat level surface.

Using Hardware provided, use correct bolt length for the desired deck height. Use flat Washer when needed.

Using hole in deck, place Bolt through Tie plate and bottom of deck. Thread bolt into Fastening Bar.

Make adjustments as needed to locate Sliding Base to desired location.

Secure bolt.

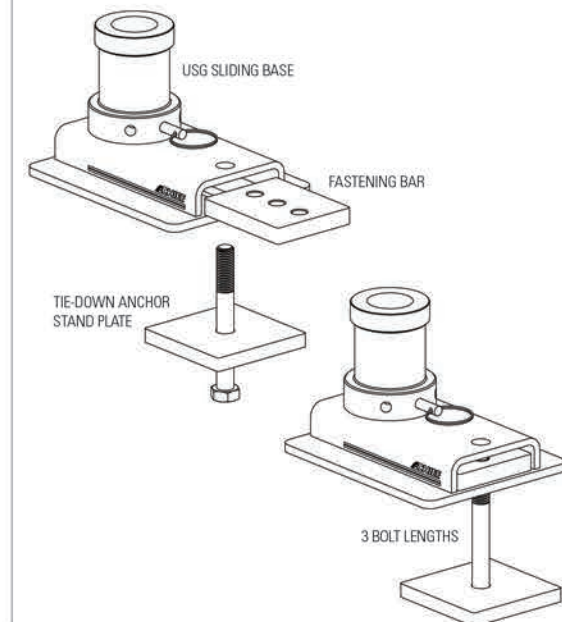

Structural Holding Package 300021

Part #300021 Weight: 555 lbs. (252 kg)

This Structural Holding Package is conveniently mounted on a tool board that outlines each component making it simple to identify where the part goes; all of this affixed to an easy-to-roll cart designed for the technician's convenience and a clean looking shop.

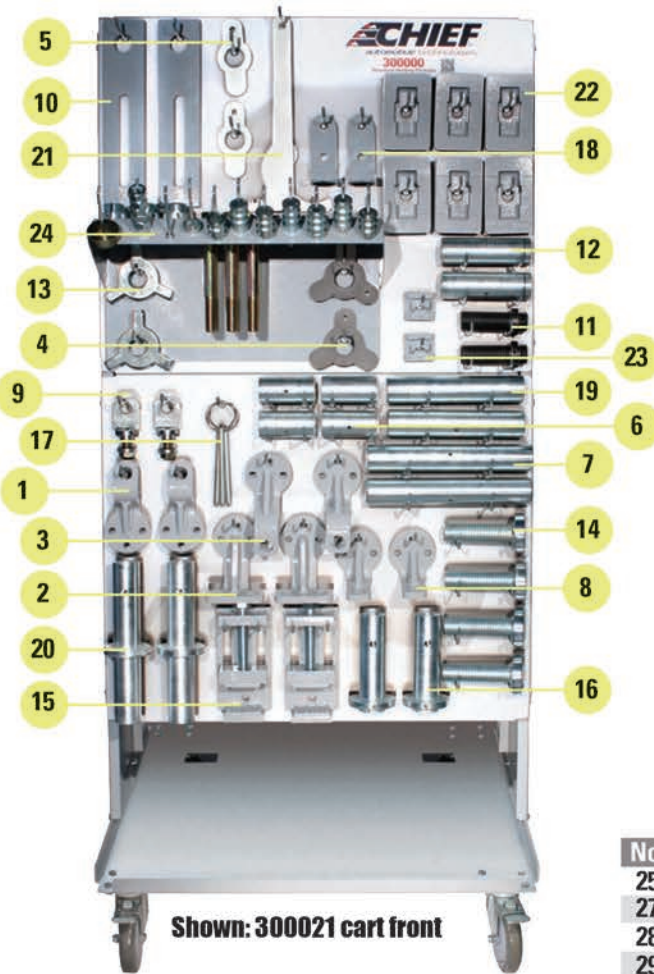

Shown: 300021 cart front

No.	Part No.	Qty.	Description
1	502000	2	Vertical Fixture Short
2	502005	2	Horizontal Fixture Large
3	502008	2	Vertical Fixture Tall
4	502014	2	Wing Nut, Parts Holding - LH
5	502015	4	Wing Nut, Parts Holding - RH
6	502016	4	4" Extension Tub
7	502017	2	12" Extension Tub
8	502019	2	Tall Horizontal Fixture
9	502026	2	Angle Adaptor Clamp Ass'y
10	502031	2	Base Plate
11	502033	2	Adapter, Parts Holding Lower
12	502034	2	Center Tub Parts Holding Turn Buckle
13	502038	2	Rigging Nut
14	502039	4	Structural Holding Adapter Ass'y
15	502042	2	Structural Vise Ass'y
16	502055	2	Short Tub Base Stand Ass'y
17	502058	4	Release Pin Ass'y
18	502060	2	Wrist Block
19	502061	2	10" Extension Tub
20	502063	2	Tall Tube Base Stand Ass'y
21	502067	1	Spanner Wrench Ass'y
21	502069	1	Spanner Wrench Ass'y
22	607371	6	Fastener Plate, UAS
23	638133	2	Jaw Clamp Ass'y
24	502062	1	Bolt Tray, Structural Holding

Vertical fixtures can mount to locations such as the suspension mounting areas creating a very strong hold for structural repairs.

The large horizontal fixture allows the ability to hold and control the end of a rail or structure for alignment or replacement of that component.

The structural holding package can be used to make **eight point holding** where needed with suspension in or out.

The system can be used for **Unitized and Full Frame vehicles** utilizing the vise clamp to hold full frame rails.

No.	Part No.	Qty.	Description
25	502070	1	Bolt Tray, Structural Holding, F150
27	640114	4	F150 Running Board Bracket Ass'y
28	640004	4	Weldment, Pinch Weld Base, F150
29	498110	4	Pinch Jaw with Nails Complete
30	640076	4	Formed Vertical Clamp, F150
31	640120	6	Weldment, Cab Mount, F150
32	640100	6	Support Plate, Cab Mount, F150
33	682953	4	Plate, EZ-Liner Tie Bolt

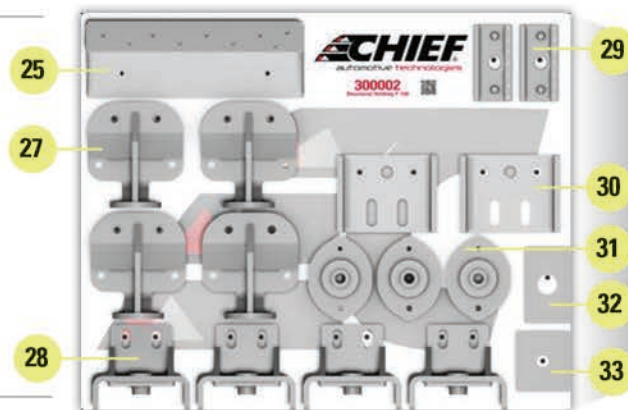

Shown: 300021 cart back



This **Tool Board** allows three ways to create holds for repairs:

The **Rigid Cab Mounts** are used to replace the rubber factory cab mounts during structural repairs.

Additional holds can be made when using the **90° Angle Pinch-Weld Jaws** that mount to the rocker flange in conjunction with the FAST Anchoring system.

A third method of holding is using the **Running Board Fixture** in conjunction with the base and fixture extensions within this parts package.

TOOL BOARD PACKAGES



FAST Anchoring System

619202 – Wall Mount Weight: 540 lbs. (245 kg)

619203 – Cart Mount Weight: 625 lbs. (284 kg)

Anchors the majority of pickup trucks, SUVs and full frame cars when used with Universal Anchoring System (UAS, USC) stands. Design allows broader anchoring points for measuring. Components either allow or prevent rail movement. The system's long crossbars can be rotated to match the slope of any attachment or frame rail.

No.	Part No.	Qty.	Description
1	539400	2	3.5 L Bracket
2	539404	2	7.5 L Bracket
3	539360	2	Chief Clamp Half
4	539365	2	Chief Clamp Base
5	539539	2	Tie-back Bracket
6	682953	6	Plate, EZ Liner Tie Bolt
7	539327	2	U-Bolt
8	539438	4	Spacer .125
	539407	2	Spacer .25
	539408	2	Spacer .5
	539409	2	Spacer 1.0
	539410	4	Spacer 2.0
9	539443	1	Hardware Holder
9a	539263	1 Pkg	Hardware Bolts Package
10	539423	2	Spring Shackle Assembly
11	539490	2	Vertical Clamp Assembly
12	628220	2	Turnbuckle Assist
13	539341	2	Spring Bolt Vise Assembly
14	539337	2	Narrow Rail Vise Clamp
15	508281	4	Universal Adapter Tube Without Clamps
16	539541	4	Riser Bar
17	539415	2	Long Crossbar

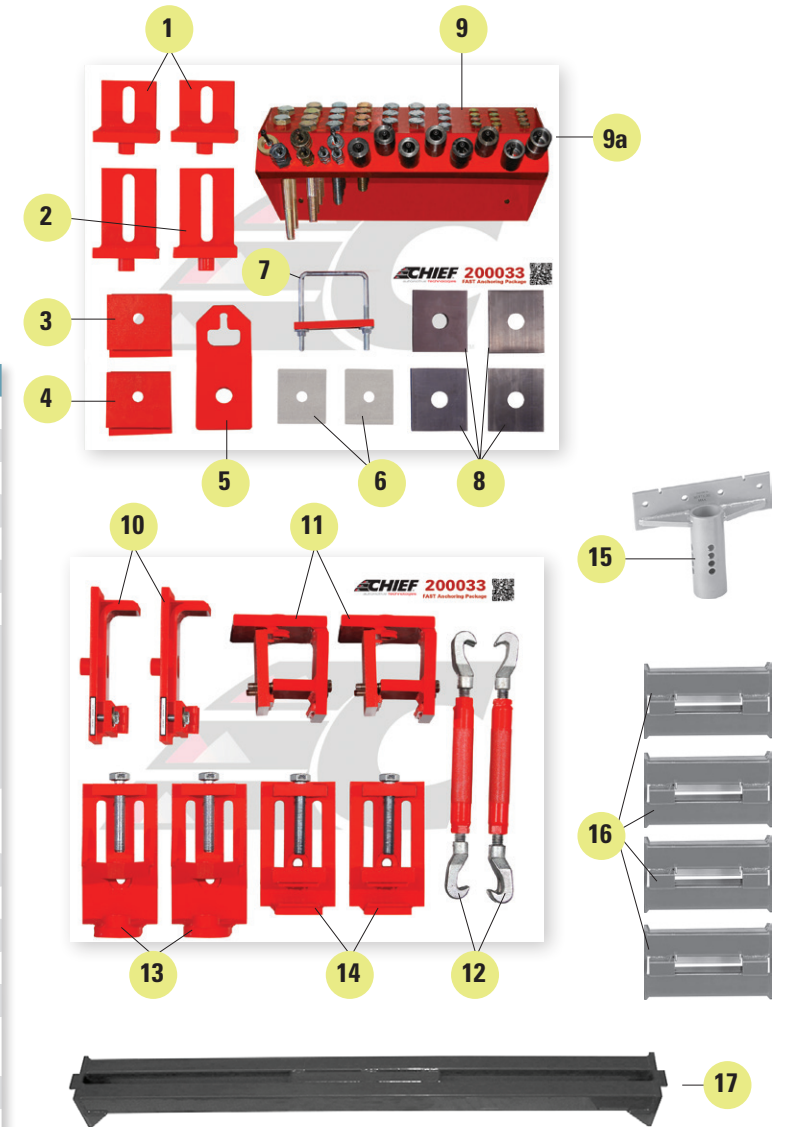

Tool Board Cart

619275 Weight: 100 lbs. (45.36 kg)

Chief Tool Boards may be wall-mounted or gain mobility by mounting them to this sturdy Tool Board Cart!



TOOL BOARD PACKAGES



Chief Tool Board Packages feature the most innovative tools for repair. Pulling accessories are available in various configurations, offering maximum versatility to keep pace with evolving automotive design. Make precise pulls on hundreds of unitized and conventional frame models while minimizing structural distortion.

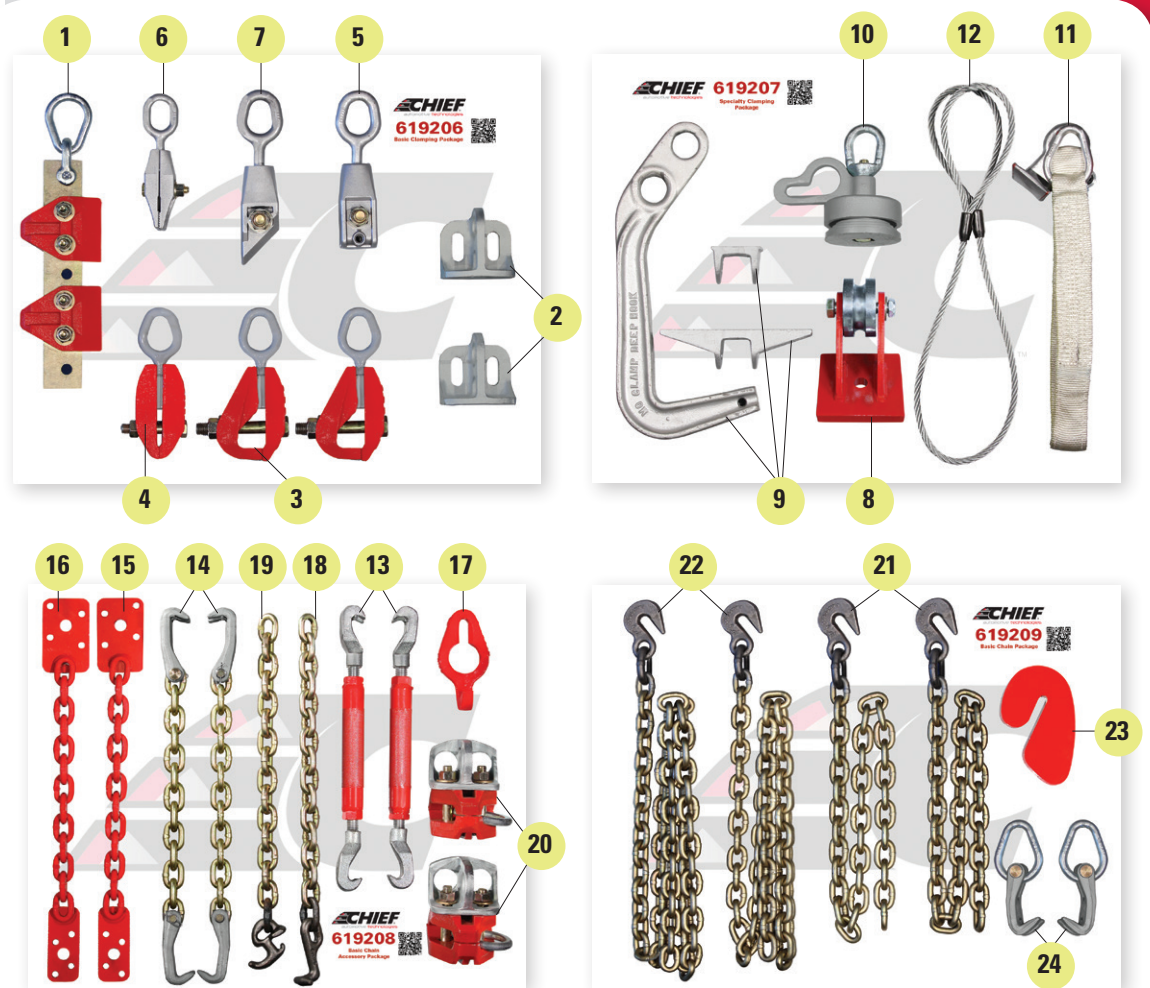

Deluxe Chain & Clamping Accessory Package

619204 – Wall Mount
Weight: 330 lbs. (150 kg)
619205 – Cart Mount
Weight: 400 lbs. (182 kg)

No.	Part No.	Qty.	Description
1	611880	1	Unitized Body Clamp
2	624235	2	Chief Attachment Side-Pull
3	672034	2	2" Self-Tightening Clamp
4	672000	1	1-1/2" Self-Tightening Clamp
5	CL1290CA	1	Chief Bite-Tight C-Clamp
6	CL0690CA	1	Chief Mini Bite-Tight Clamp
7	CL1590CA	1	Chief Angle Bite-Tight Clamp
8	697330	1	Down-Pull Attachment
9	MC6400	1	Regular Deep Hook Set, Mo-Clamp
10	619111	1	Boltless Strut Tower Puller
11	602896	1	Nylon Fender Strap
12	602909	1	Cable Sling
13	628220	2	Turnbuckle Assist
14	605261	2	Bumper Puller, w/18" Chain
15	610870	1	Pulling Plate, Right
16	610888	1	Pulling Plate, Left
17	619057	2	Slotted Chain Hook
18	602749	2	'T' Hook, w/18" Chain
19	602757	2	'R' Type Hook, w/18" Chain

No.	Part No.	Qty.	Description
20	611899	2	All-Angle Clamp
21	602853	2	Chain, Tie-Down, 3/8" x 4' w/Hook
22	602861	2	Chain, Tie-Down, 3/8" x 8' w/Hook
23	606548	2	Slotted Chain Anchor
24	610984	2	Chain Connector
	619289	4	Wall Board Frame
	619013	1	Users Manual, Self-Tightening Clamp
	619242	1	Board Assembly, Basic Clamping
	619271	1	Bolt Bag Package, Basic Clamping
	619214	1	Basic Clamping Layout Details
	619245	1	Board Assembly, Specialty Clamping
	619272	1	Bolt Bag Package, Specialty Clamping
	619215	1	Specialty Clamping Layout Details
	619248	1	Board Assembly, Basic Chain and Clamping
	619273	1	Bolt Bag Package, Basic Chain and Clamping
	619216	1	Basic Chain and Clamping Layout Details
	619251	1	Board Assembly, Basic Chain
	619274	1	Bolt Bag Package, Basic Chain
	619217	1	Basic Chain Layout Details



WELDING



CALL US TODAY

FOR THE BEST EQUIPMENT & SERVICE!

(855) 999.SCCE



MI300T

THREE-PHASE SPOT WELDER

Chief's MI300T high performance spot welder is the ideal solution for all high strength steel body repairs.

Easy to handle with reduced weight

Features the new GENIUS clamp allowing an automatic retraction of the electrodes for quick access of the welding area. Auto-mode allows welding without entering any parameters into the machine cutting welding time in half. Water lines automatically connect when changing arms reducing set up time.

INTELLIGENT WELDING

AUTO mode: automatically recognizes steel type, sheet-metal thickness

Multiple programs available:

Normal, Manual, Multi, Auto, Manufacturer and Energy

Tracking saves the characteristics of each welding spot to the SD card



Reversible clamp support

Features:

- Watercooled power cables, electrodes and caps
- 5.7" LCD screen
- Automatic adjustment of pressure between electrodes
- Spot count feature to determine the caps lifetime
- 80 mm of automatic opening capacity (20 mm at rest)

G1 arm features a motorized and adjustable overhanging arm with pulley.

- Easy to handle, the overhanging arm allows the height to be adapted to all working conditions
- Extends 47" out and up to 100" up from the power source creating a wide working area.
- Rotates up to 30°
- Foldable to optimize space

Available power supply:

MI300T #CELO69176 > 208V-240V / 40 amp fuse
- 3 phase power

MI300T #CELO71223 > 480V / 20 amp fuse
- 3 phase power

SPECIFICATIONS	
Power Supply	208-240V or 480V
Fuse	40 A slow blowing for 208V, 20 A for 480V
Frequency	50/60 Hz
Supply Power	14 kVA (80 kVA max)
Nominal Power by 50% ED	20kVA
Welding Current Max.	14,500 A DC (at 230V)
Electrode Force	550 daN with 8 bars (1236 lbf with 116 PSI)
Ambient Temperature	41° to 113° F (5° to 45° C)
Protective System	IP 21
Weight w/o Accessories	Approx. 220 lbs. (100 kg)
Pliers Weight	23.1 lbs. (10.5 kg)
Dimensions H / W / D	36.4" / 25.6" / 31.5" (92.5 x 65 x 80 cm)
Cable Length	Input mains cable: 26' (8m) Weld cable: 20' (6m)
Cooling Liquid Capacity	8 gallons (30 liters)

Multifunction gun - single-point, swaging, studs, bolts, washers

- Easy arm rotation - access hard to reach areas
- Automatic cooling connection
- Remote controlled clamp controls opening and welding adjustments
- Lockable Gyroscope
- Handle, lever and reversible clamp support (right or left)

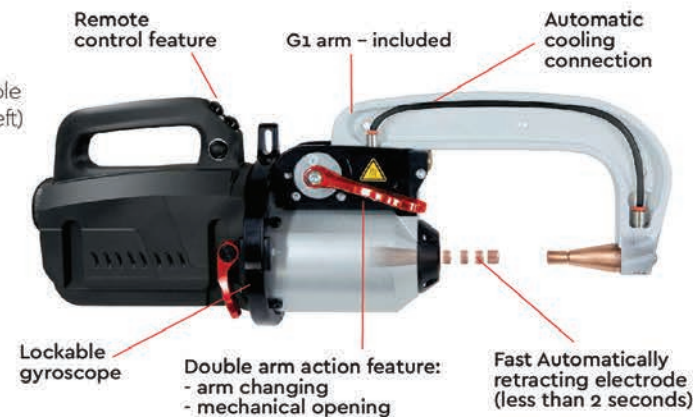

Lockable gyroscope

Double arm action feature:
- arm changing
- mechanical opening

Fast Automatically retracting electrode (less than 2 seconds)

MI300T standard equipment



MI300T unit

Monopoint electrode

Inertia hammer

Consumables box

Cap remover

Arm support

CEL 022768

G1 Arm

Optional arms

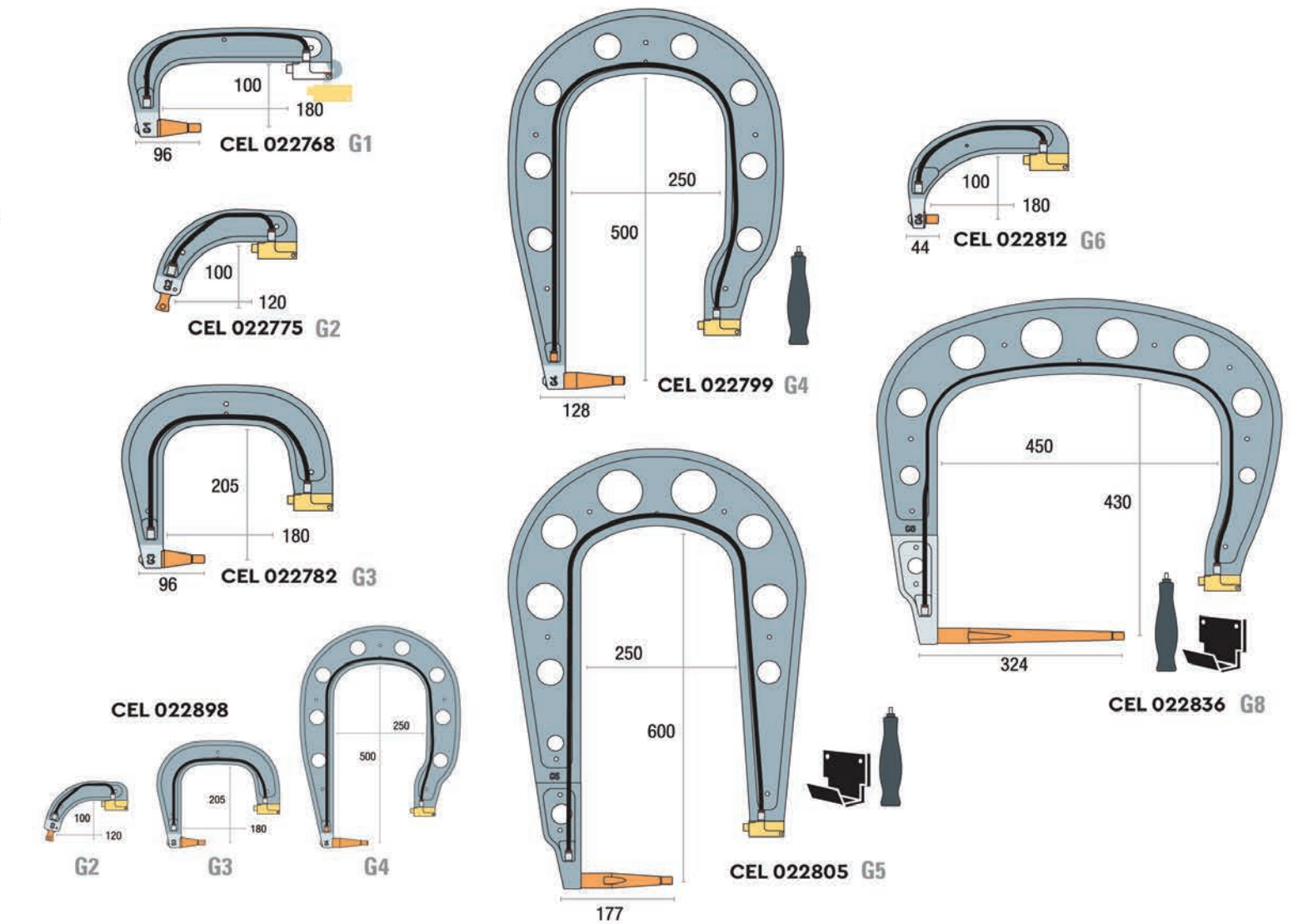

CEL 022768 G1

CEL 022775 G2

CEL 022782 G3

CEL 022898

G2

G3

G4

CEL 022799 G4

CEL 022805 G5

CEL 022812 G6

CEL 022836 G8



Improve the speed, quality and profitability of every repair you make.

©2021 VEHICLE SERVICE GROUP™
Printed in the U.S.A. All Rights Reserved. Unless otherwise indicated, CHIEF AUTOMOTIVE TECHNOLOGIES, VEHICLE SERVICE GROUP™, DOVER and all other trademarks are property of the Dover Corporation and its affiliates. Chief Automotive Technologies reserves the right to alter product specifications and/or package components without notice or liability, excluding changes to components subject to FCC & IC regulations.

NOTHING ELSE IS A
CHIEF

NEW!

MI200T™

ELEKTRON TRUE AUTOMODE

Chief's New MI200T Spot Welder is the ideal solution for all high strength steel body repairs.

- Simple to use LCD user interface
- Ergonomic and lightweight pliers
- Up to 14500A output power at 40% less input power*
- High duty cycle without waiting for cool down
- Liquid cooled to the tips
- Nearly 20' of welding cable provides increased reach
- C-pliers with multiple size arms available

*power usage compared to standard cable pliers welders



CEL025000



THE NEW MI200T FEATURES A COMPACT TECHNICIAN FRIENDLY CONTROL PANEL

Elektron TrueAutomode:

- Detects and adjusts welding parameters
- Logs data for each repair
- Provides feed back on the results of every weld



Every MI200T Comes Ready to Weld with this Standard Equipment:



Overhead Balancer



Insulated C1 Arm



360° Gyro C Arm



Arm Mounting Bracket



Starter Box of Caps

Customize your Welder with These C - Arms:

Customize your MI200T with the multiple arms available for all of your welding needs.



C1 Arm (CEL019140)
Insulated C1 (CEL021402)

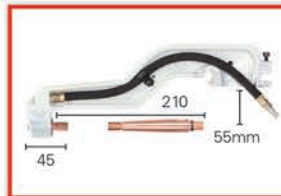

C2 Arm (CEL019133)
Insulated C2 (CEL022386)



C3 Arm (CEL019157)
Insulated C3 (CEL021419)

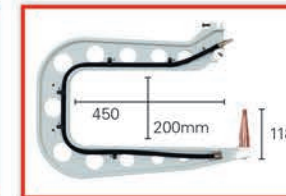

C4 Arm (CEL019164)
Insulated C4 (CEL021426)



C5 Arm (CEL019294)
Insulated C5 (CEL022393)

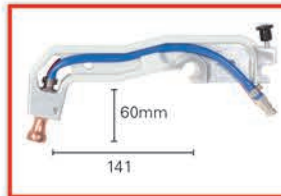

C6 Arm (CEL019775)
Insulated C6 (CEL022409)

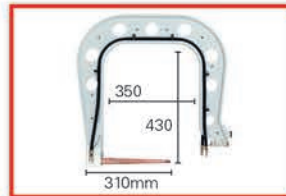

C7 Arm (CEL020009)
Insulated C7 (CEL021433)



C8 Arm (CEL020016)
Insulated C8 (CEL021440)

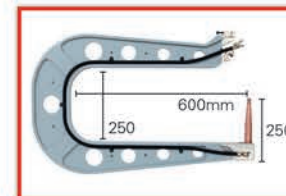

Insulated C9 (CEL020078)

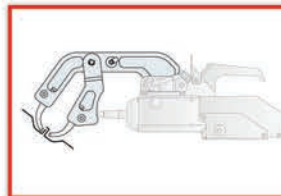

C10 Arm (CEL051638)



C11 Arm (CEL053649)



Single Sided Kit (CEL051010)



C2 + Insulated C3 and C4 (CEL021457)



C2 + C3 + C4 (CEL019126)



C2 + C3 + C5 + C6 + Insulated C9 (CEL050044)

For Other Accessories Visit chiefautomotive.com

All C arms rated 550daN except C6 and C10.

NO MATTER THE REPAIR, TRUST OUR FULL LINE OF WELDERS, JOINING PRODUCTS AND SHOP TOOLS.

C Arm Applications:

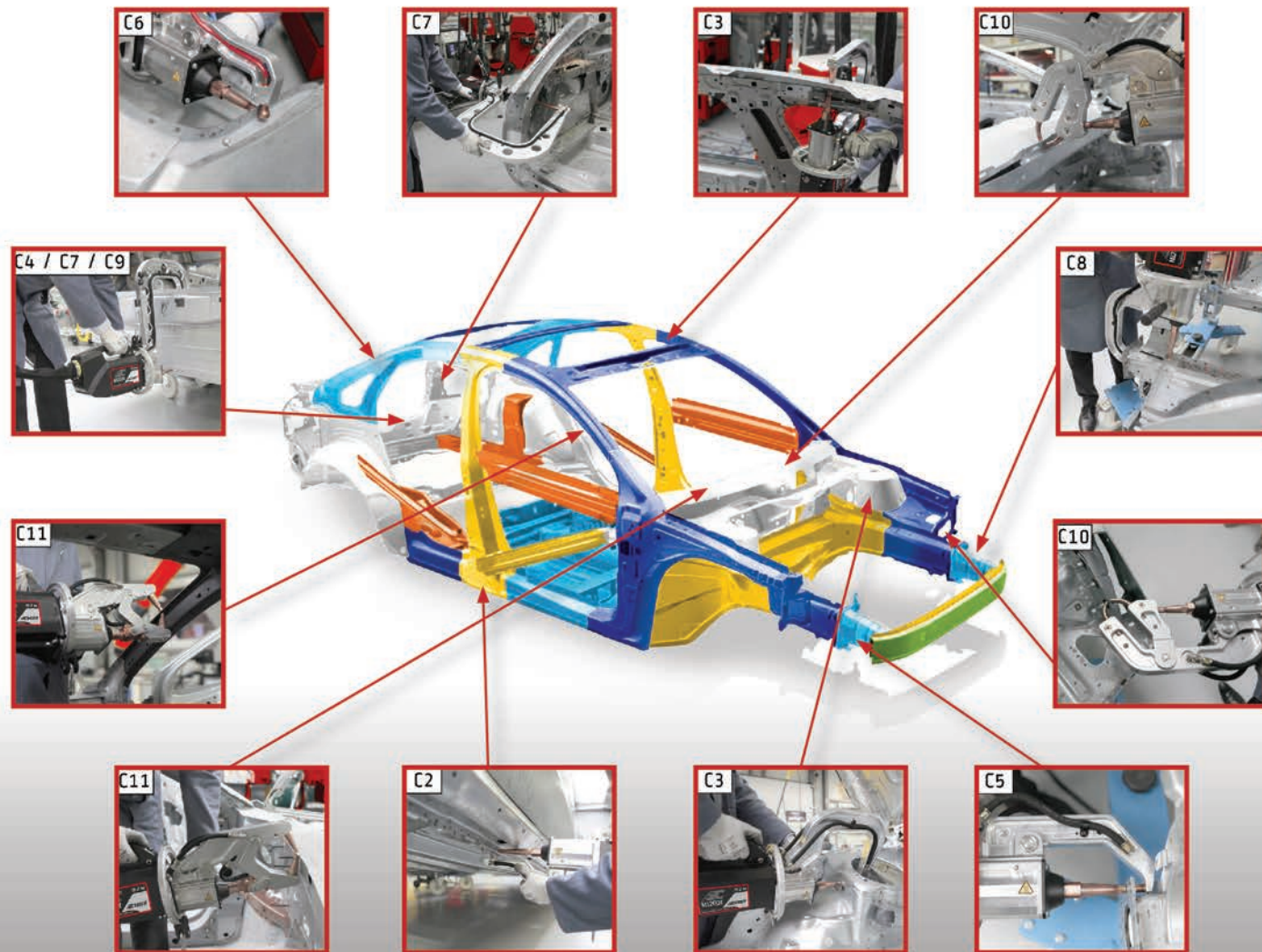

MI200T Performance Specifications:

SPECIFICATIONS	MI200T
Power Supply	208-240V (3 phase)
Fuse	40 A slow blowing
Frequency	50/60 Hz
Supply Power	14 kVA (80 kVA max)
Nominal Power by 50% ED	20kVA
Welding Current Max.	14,500 A DC (at 230V)
Electrode Force	550 daN with 8 bars (1236 lbf with 116 PSI)
Ambient Temperature	41° to 113° F (5° to 45° C)

SPECIFICATIONS	MI200T
Protective System	IP 21
Pliers Weight	23.1 lbs. (10.5 kg)
Weight without Accessories	Approx. 220 lbs. (100 kg)
Dimensions H / W / D	36.4" / 25.6" / 31.5" (92.5 x 65 x 80 cm)
Cable Length	Input mains cable: 26' (8m) Weld cable: 20' (6m)
Quantity of Cooling Liquid	8 gallons (30 liters)



MultiMig522



Multitool Workstation



Heavy Duty Rivet Gun



Fume Dog



Vulcan ADU

NEW!



INCLUDES Built-in cart for easy welder handling and storage for gas cylinder

MULTIMIG 525

Welding and brazing of aluminum alloys, galvanized sheet metal, stainless, and high-strength steel.

Three standard MIG torches (one brazing, one aluminum, one steel) are mounted simultaneously with three different reels and wire.

Double Pulse feature - mechanically and electrically controls the welding parameters to achieve a TIG-looking weld bead making aluminum welding easier.

Features

- OEM required synergic pulsed technology - includes a complete set of programs
- Inverter technology enables precision control of output power
- Many programmable settings are available to customize the unit operation to meet most working conditions.
Settings include: Hot Start, Crater Fill, Pre / Post Gas, Arc Length, 2T / 4T Start Mode, Spot / Pause function, Inductance, Burn Back, Soft Start, etc.
- Two regulators supplied

SPECIFICATIONS	
Single Phase Input	230V 50/60Hz + 15% to -20%
Supple Fuse Rating (slow blow)	16A
Input Power	6.3 KVA 20% 3.8 KVA 60% 3.1KVA 100%
Current Adjustment Range	20A to 200A
Duty Cycle (10 min 40°C) According to IEC 60974.1	200A 20% 140A 60% 120A 100%
Stepless Regulation	Electronic
Standard Supplied Synergic Programs	0.6/.08/0.9/1.0 Steel .08/0.9/1.0 Stainless 0.8/0.9/1.0/1.2 AL 0.8/0.9/1.0 CuSi3%
Max. Wire Spool Size	DIAM. 200 mm / 5kg
Protection Class	IP 23 S
Weight	232 lbs
Dimensions Inches	23 x 39 x 41h



Welding and brazing of aluminum alloys, galvanized sheet metal, stainless, and high-strength steel.



INCLUDES Built-in cart for easy welder handling

Storage for gas cylinder

SPECIFICATIONS	
Single Phase Input	230V 50/60Hz + 15% to -20%
Supple Fuse Rating (slow blow)	30A
Input Power	5.7 KVA 20% 4.1 KVA 60%
Current Adjustment Range	15A to 200A
Duty Cycle (10 min 40°C) According to IEC 60974.1	200A 60% 160A 100%
Stepless Regulation	Electronic
Standard Supplied Synergic Programs	0.6/.08/0.9/1.0 Fe, Stainless 0.6/0.8/0.9/1.0/1.2 AL 0.8/0.9/1.0 CuSi3 0.9 Flux core
Max. Wire Spool Size	Ø 200 mm / 5kg Ø 300 mm / 15kg
Protection Class	IP 23 S
Weight	165.3 lbs
Dimensions Inches	23.2 x 37.5 x 39.5h

DOUBLE PULSE TECHNOLOGY

- mechanically and electrically controls the welding parameters to make aluminum welding easier and for increased confidence

Features, Advantages, Benefits

- Synergic pulsed technology is required by most OEMs for aluminum welding. Includes a complete set of synergic programs in memory for brazing, welding and aluminum wire.
- Inverter technology enables precision electronic control of output power for better welds.
- **GREEN technology** - Integrated Power Factor Correction (PFC) technology reduces input power by avoiding energy waste found in most electronic-based equipment and ultimately reduces operating costs.



With the MultiMig 522, a Standard MIG torch and unique Push-Pull torch are mounted simultaneously with different reels and wire.

- Two types of torches can be used with MultiMig power source - a standard MIG torch or the push-pull torch. The push-pull system torch has an up-down digital current adjust at your finger tip, thanks to a feeder built into the grip. The very small and light weight torch (no bulky spool-gun) enables real-time control of welding process by control of the wire feed speed and current level. The push-pull system corrects many of the problems encountered when feeding and welding soft aluminum wire, down to 0.6mm.
- Many programmable options are available to customize the unit operation to meet most working conditions. Options include: Hot Start, Crater Fill, Pre / Post Gas, Arc Length, 2T / 4T Start Mode, Spot / Pause function, Inductance, Burn Back, Soft Start, etc.

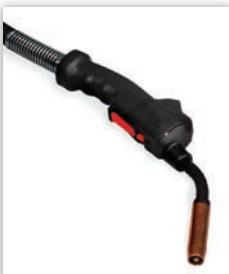

MULTIMIG 511

Part #EL900012 with Push-Pull Torch
Part #EL900011 with Standard Aluminum Torch
Part #EL900070 with Brazing Torch

*A push-pull torch designed specifically to optimize aluminum welding.
Synergic pulsed welder with full set of welding programs!*



Welding and brazing of aluminum alloys, galvanized sheet metal, stainless, and high-strength steel.

The push-pull system has an up-down digital current adjust at your finger tip - enables real-time control of welding process. Programmable options are available to customize the unit operation.

Features

- OEM required synergic pulsed technology - includes a complete set of programs
- Inverter technology enables precision control of output power
- **GREEN technology** - Integrated Power Factor Correction (PFC) technology reduces operating costs.

INCLUDES Built-in cart for easy welder handling and storage for gas cylinder



Push-pull torch



Standard torch



#EL900012 with Push-Pull Torch



SPECIFICATIONS	
Single Phase Input	230V 50/60Hz + 15% to -20%
Supple Fuse Rating (slow blow)	30A
Input Power	5.7 KVA 20% 4.1 KVA 60% 3.2 KVA 100%
Current Adjustment Range	20A to 200A
Duty Cycle (10 min 40°C) According to IEC 60974.1	200A 20% 140A 60% 120A 100%
Stepless Regulation	Electronic
Standard Supplied Synergic Programs	0.6/.08/0.9/1.0 Fe, Alu 0.6/0.8/0.9/1.0/1.2 AL 0.8/0.9 Stainless Steel, CuSi3 0.9 Flux core
Max. Wire Spool Size	Ø 200 mm / 5kg Ø 300 mm / 15kg
Protection Class	IP 23 S
Weight	99.2 lbs
Dimensions Inches	18.9 x 33.7 x 32.5h

MIG 240

Synergic Mig Welder

The MIG240 AUTO with Synergic Mode is a single phase MIG welder designed for welding steel.



Easy to use Synergic Technology

The machine determines the optimum wire speed by selecting the type of wire, wire diameter, and welding current.

Welding parameters are automatically saved

Memory save feature for each torch and activation of the 'last used' welding parameters (wire diameter, wire type and mode) are automatically saved.

Features, Advantages, Benefits

- Wire reel motor with 4 drive rolls are suitable for 200mm and 300mm wire reels (15kg max)
- 3 welding modes available: Standard (2T) / Spot / Delay

SPECIFICATIONS	
Weldable wires	0.6 - 0.8mm
Welding Current, 60%	90A (40°C)
Duty Cycle I Max	140A 15% (40°C)
Welding current range	15 - 160 A
Mains voltage	208 / 240 V / 1Ph
Mains Fuse	16 A (CEE 16)
Dimensions D/W/H	470 x 770 x 790mm
Weight	110 lbs. (50kg)



NEW!

Standard 15A TORCH



MULTIMIG822

THREE-PHASE MIG / MAG WELDER

The MULTIMIG 822 employs a MIG-MAG inverter power source with pulse and double pulse capability.

Weld and braze vehicles made completely, partly, or simultaneously of materials such as galvanized sheet metal, high-strength steels and aluminum alloys.

Two types of torches can be used – a standard MIG torch or push-pull torch with digital current adjustment.

Each is mounted with different reels and wire. 2 wire feed motors equipped with 4 aluminum rollers makes it possible to use 2 different wire spools, and keep 2 different types of torches mounted simultaneously with different wires.

INVERTER / MIG-MAG WELDING

Inverter technology enables precision electronic control of output power for quality welds.

Unit Includes:

- Set programs for welding and brazing of aluminum alloys, galvanized sheet metal, stainless, and high-strength steel
- Over 75 saved synergic curves, pulse and double pulse function
- Built-in cart for welder handling and storage for gas cylinder
- Support for 2 shielding gas bottles
- 5" display LCD screen
- 4-roller wire feeder
- 300 mm and 200mm spool compartments
- Up / Down PUSH-PULL torch connection for adjustment

SPECIFICATIONS	
Three Phase Input	208-480V 50/60 Hz + 15% to -20%
Supply Fuse Rating	16A
Input Power	9.0 kVA 20% 8.3 kVA 40% 6.3 kVA 60% 4.9 kVA 100%
Current Adjustment Range	20A to 270A
Duty Cycle (10 min 40°C) According to IEC 60974.1	270A 20% 250A 40% 220A 60% 180A 100%
Stepless Regulation	Electronic
Synergic Programs	0.6/.08/0.9/1.0 Fe, Stainless 0.6/0.8/0.9/1.0/1.2 AL 0.8/0.9/1.0/1.2 Inox 0.8/0.9/1.0 CuSi3
Max. Wire Spool Size	Ø200 mm / 5kg Ø300 mm / 15kg
Protection Class	IP 23 S
Weight	167 lbs.
Dimensions / Inches	23" w x 37" t x 39" h



Standard
MIG torch



Adjustable
air cooled
push-pull
torch



Improve the speed, quality and profitability of every repair you make.

©2020 VEHICLE SERVICE GROUP™
Printed in the U.S.A. All Rights Reserved. Unless otherwise indicated, CHIEF AUTOMOTIVE TECHNOLOGIES,
VEHICLE SERVICE GROUP™, DOVER and all other trademarks are property of the Dover Corporation and its affiliates.
Chief Automotive Technologies reserves the right to alter product specifications and/or package components
without notice or liability, excluding changes to components subject to FCC & IC regulations.

CHIEF M822 12/20



COLLISION CENTER TOOLS



CALL US TODAY

**FOR THE BEST
EQUIPMENT & SERVICE!**

(855) 999.SCCE

LIFT KING LIGHT DUTY

THE SOLUTION FOR INSTANT OEM PICKUP BOX REMOVAL AND INSTALLATION

The Lift King Light Duty Package comes with everything needed to remove or install OEM pickup boxes of all sizes including 8' dually boxes.

Once the pickup box is disconnected and ready for removal, the Lift King Main Component converts from the stored position to the working position within 1 minute and with little effort. There are no tools needed. The Main Component is then connected to the pickup box, and the box is removed in less than 5 minutes, including the original setup time.

This application requires no human lifting of any type and only one technician of any size or strength for pickup box removal or installation.



LIFT KING HEAVY DUTY

THE SAFEST TOOL FOR RELOCATING FIBERGLASS AND ALUMINUM

The Lift King Heavy Duty Package comes with everything needed to remove or install semi hoods of all sizes including fiberglass and aluminum.

Once the semi hood is disconnected and ready for removal, the Lift King Main Component converts from the stored position to the working position within 1 minute and with little effort. There are no tools needed. The Main Component is then connected to the semi hood, and the hood is removed in less than 5 minutes, including the original setup time.

This application requires no human lifting of any type and only one technician of any size or strength for semi hood removal or installation.



NEW!

NOTHING ELSE IS A
CHIEF

LIFT KING COMBO

THE ULTIMATE PACKAGE FOR REPAIRS OF ALL SEMI-TRUCK HOOD SIZES

The Lift King Combo Package is a great option for shops that work on both automotive and commercial trucks.

This package includes everything needed to remove and install pickup truck boxes, including 8' dually's, and semi-truck hoods of all sizes, including fiberglass and aluminum.

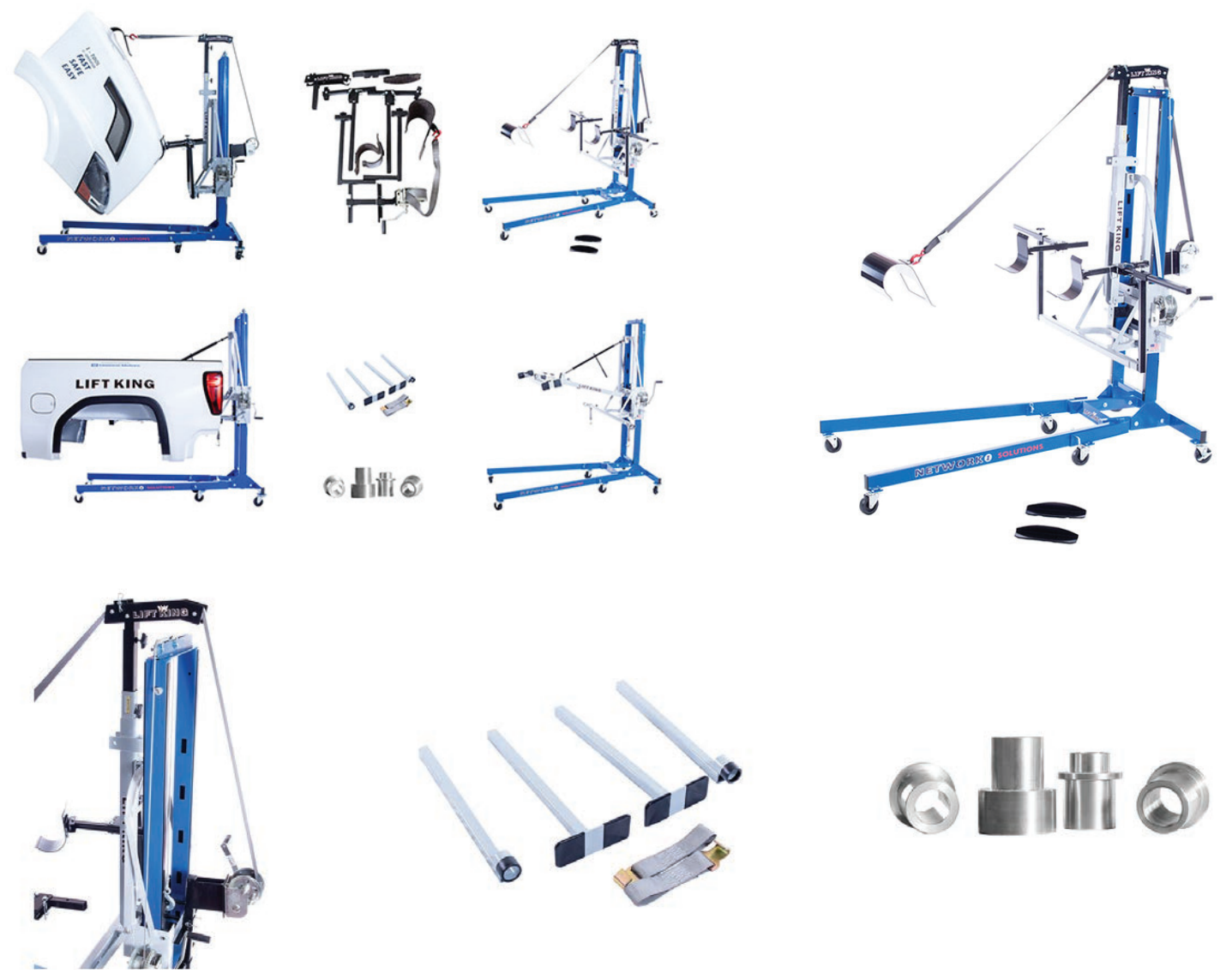

VULCAN ADU

Adhesive Debonding Unit

BREAK THE BOND OF ADHESIVE
- Chief's Vulcan ADU can break the adhesive bond on any vehicle surface; steel, aluminum, and carbon fiber using no electromagnetic field.

- Breaks the adhesive bond between glued panels or surface
- Precise temperature control - focus on one panel layer
- Microprocessor control with color touch screen
- Air and water cooled lamp for safety and extended life
- Uses infrared lamps to output focused heat to a surface
- Calibration feature to address issues when measuring different color paint and reflectivity
- Can be used to remove molding and labels
- 5-step program available to set temperature and time for curing adhesives



THE VULCAN ADU INCLUDES CART AND COOLING UNIT



CHIEF

SPECIFICATIONS	VULCAN
Voltage	230V - 60Hz (three phase)
User Interface	Color Display Touch Screen
Cable length	4M
Adjustment	Power, Time and Temperature
LAMP	
Power Output	4.8kW
Lamp Life	5000h
Cooling System	Compressed Air and Chilled Water
Temperature Control	Pyrometer
Accessories	Temperature Calibrator Trolley 3461T

Lit# CHIEF M1200T 03/16
©2016 VEHICLE SERVICE GROUPSM
Printed in the U.S.A. All Rights Reserved. Unless otherwise indicated, CHIEF AUTOMOTIVE TECHNOLOGIES, VEHICLE SERVICE GROUPSM, DOVER and all other trademarks are property of the Dover Corporation and its affiliates. Chief Automotive Technologies reserves the right to alter product specifications and/or package components without notice, excluding changes to components subject to FCC & IC regulations.

HEAVY DUTY Rivet Gun

The perfect solution for riveting operations in thin sheet metal structures.



#CHR2002

PRODUCES 10 METRIC TONS OF FORCE!

The HD rivet gun is the strongest mobile hydraulic tool for bodywork repair with double acting hydraulics that can drive 10 tons of compressive force and retract with 8 tons of tension force.

Specifically developed for riveting sheet metal in the autobody repair field where high insertion force is needed. Chief's rivet gun is a pneumatic-hydraulic system for riveting and pressing out self-piercing rivets. Universal technology enables adaption of various attachments for different applications. Easy to use and highly efficient - this riveting tool allows technicians to complete repairs in record time.

Features / Advantages / Benefits

Accepts universal attachments for various applications:

Riveting / Punching / Calibrating / Pressing Out / Forming

10 metric tons of compression force (22,000 lbs.) and 8 metric tons of retraction force

Highly efficient - hydraulic pressure ratio of 100:1

Adjustable, precise control over strength of compression

Sturdy construction with long life and low maintenance



All extensions are based on the PNP 90 UN 2.0 and compatible with existing riveting tool.

Basic Rivet Gun Kit Includes:



Hydraulic Gun DN4-XT²
#CHR2411H



Pressure Intensifier PNP90 SNW XT²
#CHR2410H



Kit 1 - Punching
Ø6mm + Ø8mm
#CHR2415H

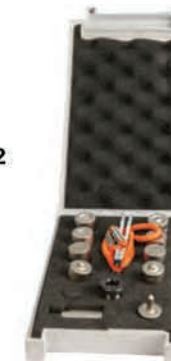

Kit 2 - Flow form rivets
Forming, SPR-Extraction
Ø6mm + Ø8mm
#CHR2416H

Riveting X² Tool Kit



Rivet Clamp NB 45
#CHR2412H



Adapter PNP90 to XT²
#CHR2417H

ACCESSORIES



Rivet Clamp NB 130
#CHR2430H



Rivet Clamp NB 240
#CHR2431H

Specifications - Rivet Gun

Technical data

Pump PNP90 SNW XT²

Length	12-63/64" (330mm)
Width	10-15/64" (260mm)
Height	8-25/64" (213mm)
Weight	23.4 lbs. (10.6 kg)
Max. input pressure	6 bar / 87 PSI
Max. operating pressure	600 bar / 8700 PSI

Hydraulic Actuator HA XT²

Length x Width x Height (including handle)	11-1/32 x 2-9/16 x 7-9/32" (280 x 65 x 185mm)
Weight	10.2 lbs. (4.6 kg)
Max operating pressure	600 bar / 8700 PSI
Travel	1-31/32" (50mm)
Max. setting force "extend"	100 kN (22,481 lbf)
Max. setting force "retract"	80 kN (17,985 lbf)

Specifications / Rivet Gun Accessories

RIVET CLAMP NB 130

Length	9-1/16" (230mm)
Width	2-61/64" (75mm)
Height	8-17/64" (210mm)
Clamp Opening	3-5/32" (80mm)
Opening Depth	5-1/8" (130 mm)
Weight	13.1 lbs. (6.2kg)

RIVET CLAMP NB 240

Length	15-23/64" (390mm)
Width	2-61/64" (75 mm)
Height	13-25/32" (350mm)
Clamp Opening	5-33/64" (140 mm)
Opening Depth	9-29/64" (240 mm)
Weight	25.9 lbs. (11.6 kg)



©2018 VEHICLE SERVICE GROUP^{PM} Printed in the U.S.A. All Rights Reserved. Unless otherwise indicated, CHIEF AUTOMOTIVE TECHNOLOGIES, VEHICLE SERVICE GROUP^{PM}, DOVER and all other trademarks are property of the Dover Corporation and its affiliates. Chief reserves the right to alter product specifications and/or package components without notice, excluding changes to components subject to FCC & IC regulations.

Rivet Gun

Easy to use, lightweight
and highly efficient

This riveting tool allows your technicians to complete all common riveting operations in thin sheet metal structures in record time.



#CHR2001

Perfect Rivet Every Time.

Chief Rivet Guns allow you to quickly restore cars, trucks and heavy duty vehicles back to factory specifications with a professional and seamless finish. With durable construction, a variety of attachments the rivet guns can handle any job you throw at them.

Specifically developed for riveting sheet metal in the autobody repair field, this rivet gun is a pneumatic-hydraulic system which easily adapts various attachments for different applications. The hydraulic pump is pneumatically driven. The pressure intensifier, with a ratio of 100:1, delivers hydraulic output pressure of 8702 psi (600 bar) with input pressure of only 87 psi (6 bar). When the equipment's preset final pressure is reached, the pump stops and maintains constant pressure, using a pneumatically controlled pressure regulator.

Features, Advantages, Benefits

Universal - allows for attachments for various applications:

Riveting / Punching / Pressing Out / Calibrating

Highly efficient - pressure ratio of 100:1

Precise control over strength of impact

Sturdy construction with low maintenance

The basic tool kit contains the pneumo-hydraulic pressure intensifier a hydraulic gun, an NB 40 rivet clamp and a fully equipped UN 2.0 Riveting Tool Kit.



BASIC RIVET GUN KIT



Rivet Clamp
NB 40



Hydraulic Gun
HP 35 UN



Pressure Intensifier
PNP90



Riveting Tool Kit
Locking Bolts



Case

- 1x Pressure intensifier PNP90
- 1x Hydraulic gun HP 35 Un

1x Rivet clamp NB 40

- Length x Width x Height - 4-11/64 x 1-49/64 x 6-17/64" (106 x 45 x 159mm)
- Weight - 3.4 lbs. (1.5 kg)
- Clamp Opening - 3-5/32" (80mm)
- Opening Depth - 1-37/64" (40mm)

1x Riveting tool kit RIVKIT - UN 2.0

- Setting / closed head 1/8" (3mm) rivet
- Setting / closed head 13/64" (5mm) rivet
- Setting / closed head, flow form rivet
- Punch and calibration mandrel / die
- Extraction mandrel / die
- Replacement elastomer rings
- Set of mounting tools
- Spacing adaptor

- 2x Locking bolts

Optional Accessories



Rivet Clamp NB 115 #CHR2204



Rivet Clamp NB 230 #CHR2203

Specifications - Rivet Gun

Technical data

Pump PNP90 UN 2.0

Length x Width x Height (without hoses, including handle)	12-63/64 x 9-1/16 x 8-25/64" (330 x 230 x 213mm)
Weight (without hoses)	17.1 lbs. (8kg)
Max input pressure	6 bar / 87 PSI
Max operating pressure	600 bar / 8702 PSI

Hydraulic gun HP 35 UN

Length x Width x Height (including handle)	9-11/16 x 1-31/32 x 4-9/64" (246 x 50 x 105mm)
Max operating pressure	600 bar / 8702 PSI
Travel	19/32" (15mm)

Specifications / Rivet Gun Accessories

RIVET CLAMP NB 115	8-25/64 x 1-47/64 x 8-21/32"
Length* x Width x Height	(213 x 44 x 220mm)
Weight*	6.9 lbs. (3kg)
Clamp Opening	3-5/32" (80mm)
Opening Depth	4-17/32" (115mm)

RIVET CLAMP NB 230	14-21/64 x 1-49/64 x 13-45/64"
Length* x Width x Height	(364 x 45 x 348mm)
Weight*	20.15 lbs. (9.5kg)
Clamp Opening	5-33/64" (140mm)
Opening Depth	9-1/16" (230mm)
Length spacer	3-5/64" (78mm)



Improve the speed, quality and profitability of every repair you make. Contact your local distributor or call Chief Automotive Technologies today.



NEW Dust Extractor 63L

Vacuum assisted sanding kit system with immersion separator for the automotive repair industry

Features

- Coalescing HEPA Filter - included with an efficiency of 99.97% on 0.3 micron
- CSA Certified
- Optional automatic On/Off switch allows the electrically operated vacuum cleaner to be controlled by a pneumatic hand tool



#CHD3002



Detachable oil/water tank for easy emptying of recovered materials

Accessories



Included:
20' Suction/Air Supply Hose made of static conductive PVC



Included:
Wye Connector allows two suction hoses to be used on one vacuum at the same time



Included:
Coalescing HEPA Filter



Optional:
Mist Arrester Pack



Optional:
Sieve Basket / Strainer

Specifications

EC-15 (IT-63L) SK HEPA Performance	
Vacuum Pressure	107 H ₂ O
Airflow	110CFM
Phase	Single
Horse Power	1.6 HP
Amperage	10.5 AMP
Wattage	1200 W
Hertz	60 Hz
Voltage	120 V
Noise Level	75 dB
Weight	180 Lbs
Dimensions	24" x 31" x 67" High
Plug	Included
Filtration system	Immersion Separator
Dry Recovery	1.3 gallons of dust into 7.9 gallons of neutralizing liquid



©2015 VEHICLE SERVICE GROUP™
Printed in the U.S.A. All Rights Reserved. Unless otherwise indicated, CHIEF AUTOMOTIVE TECHNOLOGIES, VEHICLE SERVICE GROUP™, DOVER and all other trademarks are property of the Dover Corporation and its affiliates. Chief Automotive Technologies reserves the right to alter product specifications and/or package components without notice, excluding changes to components subject to FCC & IC regulations. Dust Extractor 63L 10/15

CHIEF
5T POWER GUN
BODY ALIGNMENT TOOL

Perform vehicle repairs with this patented pushing and pulling car body alignment tool.

With up to 5 tons of standard power, the 5T POWER GUN allows a greater capacity to move stronger panels and do heavier repairs.



With a single hand, this battery operated power gun provides the most convenient metal re-alignment capabilities

With no cords, hoses or hand pumps needed, techs can make repairs inside and outside of the vehicle faster with this versatile auto body repair gun system.



EASY TO USE, ONE-HANDED OPERATION!

Traditional porto-power requires a tech to have a hand on the pump and ram, making it difficult to do most repair tasks. Perform a greater variety of repairs and in more vehicle areas with the push and pull power of the 5T Gun versus manual porto powers that can only pull.

FRAME RACK VERSATILITY

Use the gun as an additional tower on any frame rack and increase repair versatility by adding holding or pulling as needed. Free up rack space by using this power gun for light pulls instead of taking up valuable space on a frame rack.

Perform these pressing and pushing methods of re-aligning body parts and structures with the push of a button. The included accessory kit generates a wide range of repair options.



#EL920032
STANDARD KIT



STANDARD KIT APPLICATIONS

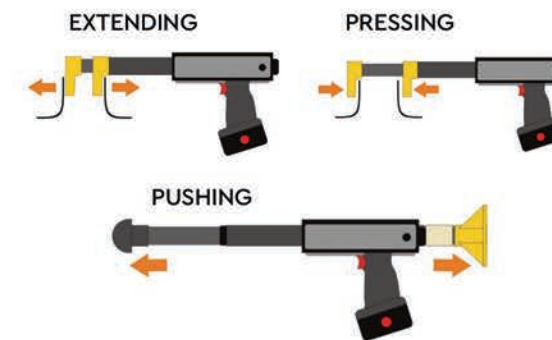

#EL920033
ACCESSORY KIT
INCLUDED WITH PURCHASE



ACCESSORY KIT APPLICATIONS

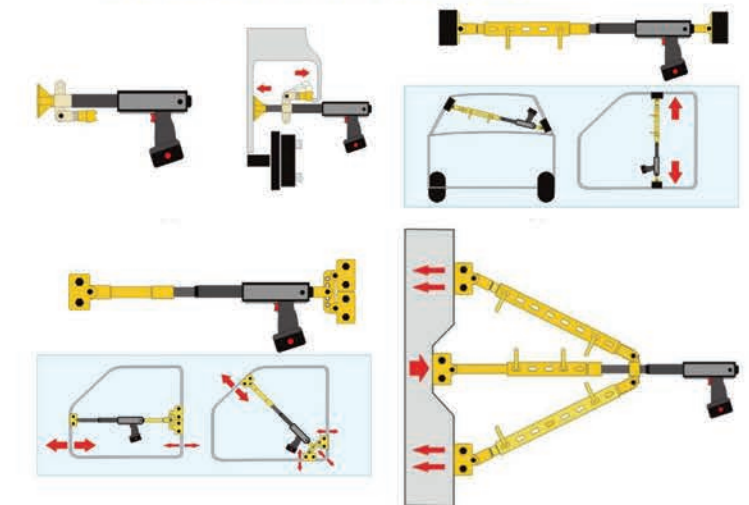

MOTIONLED ESTIMATOR LIGHT

BETAG's MotionLED 33 Estimator light makes it quick and easy for estimators to observe and accurately identify all damages on the vehicle at check in - particularly small dents & scratches that are often missed.

Features:

- Lightweight & Portable
- Battery operated, no extension cords needed 10 to 12 hours operating time on one charge
- Recharge to full capacity in 7 to 8 hours
- Light color can be alternated between warm and bright - works great on any vehicle color
- For indoor or outdoor use

Tech Specs:

- Handle Length: 87cm; effective range of the light from the handle is around 60cm
- Light Dimensions: W 34cm x H 17cm
- Weight:
 - Light: 600g
 - Handle: 1.1 kg



MOTIONLED & EXTENDER ARM

BETAG's lighting systems are equally valuable for estimators, repair planners, and technicians. Estimators use them to more easily identify and mark all the damage on a panel; and produce much higher quality images of the damage to submit to the customer or insurer.

Specialized task lighting transforms the way in which PDR and autobody technicians can straighten panels, enabling them to deliver higher-quality work, more quickly and efficiently.

The MotionLED has an integrated battery, providing 8 hours of continuous runtime. Color temperature may be changed from warm to cold light, as well as individual control (on/off) of each light strip. It may also be used or charged with an external battery or mains power.

Advantages:

- Integrated battery
- 8 hours runtime
- Easy to adjust
- Easy to assemble/disassemble
- Wide, continuous light band
- Independent control of each light strip
- Warm and cold light strips
- 360-degree rotation
- Lightweight (7Kg)



Battery Powered Motion LED: **BETAG 8421**



Extension Arm: **BETAG 8446**

Basic Clamping Package

619206 Weight: 45 lbs. (20.25 kg) – wall mounted

No.	Part No.	Qty.	Description
1	611880	1	Unitized Body Clamp
2	624235	2	Chief Attachment Side-Pull
3	672034	2	2" Self-Tightening Clamp
4	672000	1	1-1/2" Self-Tightening Clamp
5	CL1290CA	1	Chief Bite-Tight C-Clamp
6	CL0690CA	1	Chief Mini Bite-Tight Clamp
7	CL1590CA	1	Chief Angle Bite-Tight Clamp
	619013	1	Users Manual, Self-Tightening Clamp
	619242	1	Board Assembly, Basic Clamping
	619271	1	Bolt Bag Package, Basic Clamping
	619289	1	Wall Board Frame
	619214	1	Basic Clamping Layout Details (Install Sheet)

Basic Chain & Clamping Package

619208 Weight: 177 lbs. (80.25 kg) – wall mounted

No.	Part No.	Qty.	Description
1	628220	2	Turnbuckle Assist
2	605261	2	Bumper Puller, w/18" Chain
3	610870	1	Pulling Plate, Right
4	610888	1	Pulling Plate, Left
5	619057	2	Slotted Chain Hook
6	602749	2	'T' Hook, w/18" Chain
7	602757	2	'R' Type Hook, w/18" Chain
8	611899	2	All-Angle Clamp
	619248	1	Board Assembly, Basic Chain and Clamping
	619273	1	Bolt Bag Package, Basic Chain and Clamping
	619289	1	Wall Board Frame
	619216	1	Basic Chain and Clamping Layout Details (Install Sheet)

TOOL BOARD PACKAGES



Small Pulling Package

619201 Weight: 50 lbs. (22.5 kg) – wall mounted



No.	Part No.	Qty.	Description
1	602861	1	Tie-Down Chain, 3/8" x 8" w/Hook
2	602853	1	Tie-Down Chain, 3/8" x 4" w/Hook
3	606548	2	Slotted Chain Anchor, 3/8" Thick
4	611899	1	All-Angle Clamp
5	CL0690CA	1	Chief Mini Bite-Tight Clamp
6	CL1590CA	1	Chief Angle Bite-Tight Clamp
7	672000	1	1-1/2" Self-Tightening Clamp
8	672034	1	2" Self-Tightening Clamp
	619013	1	Users Manual, Self-Tightening Clamp
	619233	1	Board Assembly, Small Pulling
	619268	1	Bolt Bag Package, Small Pulling
	619289	1	Wall Board Frame
	619211	1	Small Pulling Layout Details (Install Sheet)

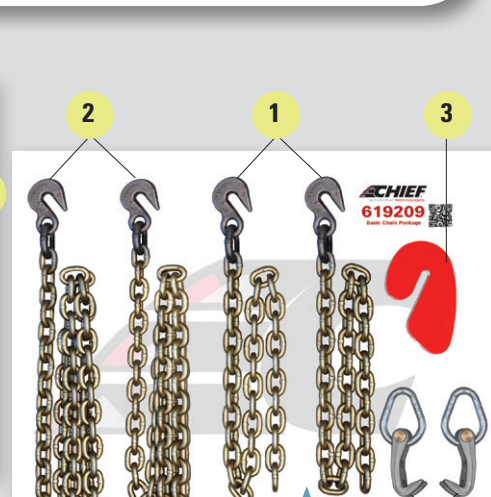

Auxiliary Pulling Packages

> Impulse Tilt

619218 – wall mounted
Weight: 89 lbs. (40.5 kg)

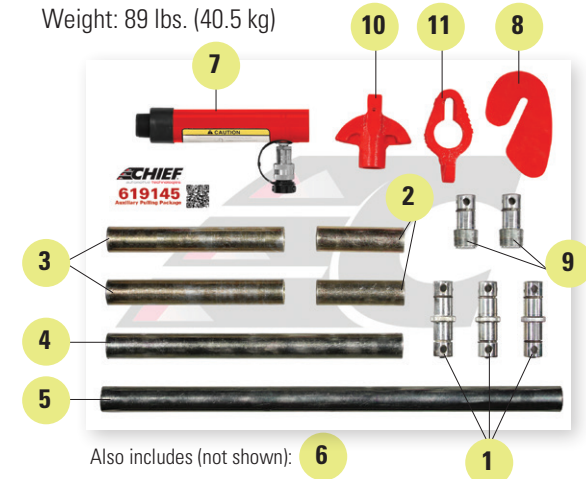

No.	Part No.	Qty.	Description
1	601834	3	Auxiliary Extension Coupling
2	601842	2	Auxiliary Extension, 6"
3	601850	2	Auxiliary Extension, 12"
4	601869	1	Auxiliary Extension, 20"
5	601922	1	Auxiliary Extension, 31"
6	602335	1	Ram V-Base
7	602360	1	Auxiliary Ram, 6" Stroke
8	606548	2	Slotted Chain Anchor
9	607849	2	Auxiliary Male Coupling
10	610829	1	Auxiliary Pulling Head
11	619057	1	Slotted Chain Hook
12	601140	1	Auxiliary Ram Base
13	601197	1	Auxiliary Ram, 6" Stroke with Quick Coupler
14	601213	1	Male / Klaw Assembly
15	601214	1	Female / Klaw Assembly
16	450441	1	Auxiliary Ram, 6" Stroke

> S21M & Titan

619219 Weight: 114 lbs. (51.7 kg) – wall mounted

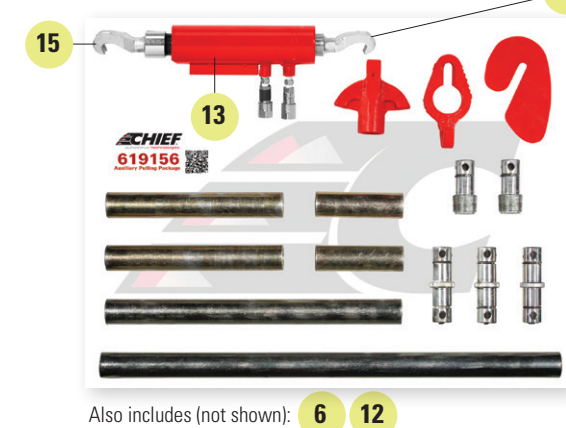

> Impulse E/VHT

619200 Weight: 107 lbs. (48.5 kg) – wall mounted

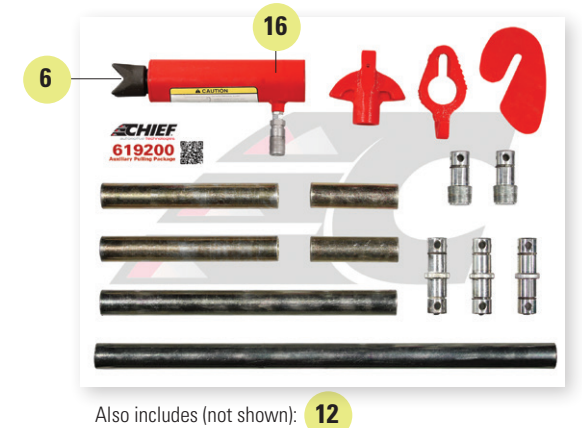

Specialty Clamping Package

619207 Weight: 45 lbs. (20.25 kg) – wall mounted

No.	Part No.	Qty.	Description
1	697730	1	Down-Pull Attachment
2	MC6400	1	Regular Deep Hook Set, Mo-Clamp
3	619111	1	Boltless Strut Tower Puller
4	602896	1	Nylon Fender Strap
5	602909	1	Cable Sling
	619245	1	Board Assembly, Specialty Clamping
	619272	1	Bolt Bag Package, Specialty Clamping
	619289	1	Wall Board Frame
	619215	1	Specialty Clamping Layout Details (Install Sheet)

No.	Part No.	Qty.	Description
1	602853	2	Chain, Tie-Down, 3/8" x 4' w/Hook
2	602861	2	Chain, Tie-Down, 3/8" x 8' w/Hook
3	606548	2	Slotted Chain Anchor
4	610984	2	Chain Connector
	619251	1	Board Assembly, Basic Chain
	619274	1	Bolt Bag Package, Basic Chain
	619289	1	Wall Board Frame
	619217	1	Basic Chain Layout Details (Install Sheet)



Also includes (not shown): 6 12

Also includes (not shown): 12



PORTABLE WELD FUME EXTRACTOR

Using Negative Airflow, the Fume Dog Portable Fume Extractor removes fumes and dust particles from the air when welding. The process removes any hazardous gases and airborne particles from your environment, making working conditions safer for everyone. The portability of the Fume Extractor makes this a great addition to any shop as it can be moved easily to maximize it's filtration efficiency.

Description:

- A 1,200 CFM Portable welding fume extractor with filter cleaning system.
- Fume Arm included
- The Fume Dog can be converted from a ground-mounted portable welding fume extractor to a wall-mounted weld fume collector out of the box.
- Can be converted to downdraft table with an additional accessory..
- The unique Air Stream Filter Cleaner allows for 5-6 times the filter life over traditional reverse pulse systems depending on application.
- Replacement filters are standard size so we can't force you to pay a ludicrous mark up for a filter you can only get from us.
- Seriously, google replacement filters on some of these things. They are priced like they are coated in powdered Rhinoceros horn.
- Steel construction, not plastic.

Specifications:

Airflow: 1200 CFM

Motor: 1.5 HP

Power: 120v / 1ph

Dimensions (in): 40.5" x 26" x 31.5"

Weight (lbs): 215 (no arm)

Arm Diameter (in): 8"



PANEL REPAIR



CALL US TODAY

**FOR THE BEST
EQUIPMENT & SERVICE!**

(855) 999.SCCE

FLATLINER BUSINESS SYSTEM

A COMPLETE WORKING STATION FOR ALL DAMAGE REPAIRS

The Flatliner Business System is the key tool—with its excellent selection of bridges and hammers—that repairs damage of any kind to standard vehicles, where all of the work is done entirely from the outside.

DESCRIPTION

- Smaller repair areas
- Shorter painting times
- Minimizes demontage
- Less demand for spare parts orders
- Saves up to 40% time on auto body repairs



ALU SLIMLINER

THE ALU SLIMLINER RANGE (A & B) PROVIDES A COMPREHENSIVE RANGE OF REPAIR SOLUTIONS FOR ALUMINUM PANEL DAMAGES.

Alu Slimliner A (6106)

A small, complete working station for small to medium collision damages on aluminum applications. Equipped with a bridge system that allows for repair on larger areas.

Alu Slimliner B (6107)

A basic working system for aluminum repair.

Alu Slimliner A (6106)

- 1 Alu Pulling Element Set
- 3 Hammers
- 3 Pulling Bars
- Alumet Spot
- Dentliner
- Individual component
- Slim Trolley
- Speedline Set

Alu Slimliner B (6107)

- Alumet Spot
- Slim Trolley
- Speedline Set



T-HOTBOX

(STEEL)

THE SMALL DENT REMOVAL TOOL

The T-Hotbox (Steel) is an innovative, dent removal tool ideal for any body shop. Although its main application is repairing small and soft dents, the T-Hotbox PDR can also repair a wave or damage areas on a panel. C
 removed during the repair pro

Includes:

- 5 meter power cable



ALU T-HOTBOX

(ALUMINUM)

THE ALUMINUM REPAIR TOOL FOR SMALL TO MEDIUM DAMAGES

The Alu T-Hotbox repairs small to medium damages on aluminum by utilizing the thermal expansion characteristics of aluminum to its advantage. During the first stage of repair, the Alu T-Hotbox measures the resonance frequency of the tool to match that of the aluminum panel. The Alu T-Hotbox then adjusts itself to optimal frequency to activate the aluminum and allow it to realign itself.



MULTITOOL

Aluminum Dent Repair Station

A Complete Workstation

With all the required tools for aluminum or steel auto body repairs. Specially designed for the repair of aluminum and steel sheet metal panels. Easy to handle, mobile workstation cabinet for dedicated dent repair, tool storage and work bench.

Features

- Anodized aluminum pulling bar kit (90 cm) with mobile feet and 10x10 cm pivoting bases. The special shape of the feet, with suction cups, will perfectly fit to the car body, including angular surfaces. The kit includes 3 tie-rods and multi-hook gripping heads for a combined or independent dent pulling operation.
- Anodized aluminum pulling system for smaller jobs and a single tie-rod with special heads that can pull either a single or a group of hooks. A circular base accessory for the pulling system (to replace the two feet) is used in the repair of small diameter dents.
- Hammer kit with 4 anodized aluminum hammers:
 1. Round head - 3.2 oz.
 2. Round head - 6.7 oz.
 3. Square head - 6.7 oz.
 4. Mallet - 20.8 oz.
- Heat gun is provided to heat the dented area of the aluminum panel that needs to be repaired.
- Heat shield gel is used to create a barrier to protect the parts of the panel that are not to be heated during the aluminum repair process.
- An angled air die grinder is provided as a dedicated tool to eliminate cross contamination during the aluminum repair. Used to remove the weld studs and/or for other sanding or grinding operations.
- A starter kit of aluminum studs, zinc-plated steel eye-bolts



Aluminum Pulling Bar Kit



Aluminum Pulling System

Includes MultiSpot M30Pro

115V aluminum capacitor discharge stud welder, complete with grounded stud gun and 2-clamp grounding cables.



WORKSTATION SPECIFICATIONS

Single phase input	115V 50/60Hz
Supply fuse rating (slow blow)	15 A
Weight	270 lbs.
Dimensions inches	39.4 x 20.5 x 61.4h



PLASTIC WELDER



CALL US TODAY

FOR THE BEST EQUIPMENT & SERVICE!

(855) 999.SCCE

Nitro-Fuzer® Welders

8000 SERIES

A nitrogen welder for every need.

Polyvance first commercialized nitrogen plastic welders in the collision repair industry in 2006 and has led the development of this technology since that time. The 8000-series Nitro-Fuzer® welders are Polyvance's sixth generation machines, combining new user-friendly innovations with the many proven features that have made Polyvance's welders the industry's most popular for over a decade.

From the top-of-the-line 8203 with nitrogen generator and digital controls to the basic, manually-controlled 8002, the 8000-series line of welders offers options for every shop and every budget. The most popular models include a heavy-duty, USA-made welder cart, but standalone models for use on a workbench are also available.

All of the 8000-series welders incorporate patent-pending new technology created by Polyvance to make the welders easier to maintain and use. All welders feature a quick change hose and wiring assembly, which makes it easy to replace a damaged torch handle or hose. Simplified maintenance reduces down time and helps keep the shop productive. In addition, all 8000-series welders include automatic low-flow power cutoff protection, precision flow valves to allow the user to adjust the flow to suit the thickness of the plastic, and a direct-reading flow gauge to ensure repeatable performance.

Two models include the ultimate convenience of an onboard nitrogen generator, eliminating the need for bottled nitrogen gas. For shops on a tighter budget, the 8202 offers automatic air-to-nitrogen switching to eliminate wasting bottled nitrogen gas, making it nearly as convenient as the top-of-the-line 8203.

All of the 8000-series welders are covered by a two-year "bumper-to-bumper" warranty covering all parts except the heating elements.

Polyvance's welders come with our industry-leading customer service and technical support. Purchase of a Polyvance welder gives the user unlimited access to our online video training library and to our telephone technical support. Polyvance offers the only hands-on training courses approved under the I-CAR Industry Training Alliance. Partner with Polyvance to increase productivity and profits today!



NITRO-FUZER® WELDERS | Features

	Analog Controls		Digital Controls	
Stand-alone				
	8000 single gas	8001 dual gas, manual switch	8200 single gas	8201 dual gas, automatic switch
With Cart				
	8002 nitrogen tank, manual switch	8003 nitrogen generator	8202 nitrogen tank, automatic switch	8203 nitrogen generator

Features	Analog				Digital			
	8000	8001	8002	8003	8200	8201	8202	8203
Digitally encoded temperature control					•	•	•	•
LED displays for power setting					•	•	•	•
Analog temperature control	•	•	•	•				
Single gas input	•			•	•			•
Switchable dual gas input		•	•			•	•	
Manual air-to-nitrogen switching		•	•					
Automatic air-to-nitrogen switching						•	•	
Precision flow valves for air and/or nitrogen flow control	•	•	•	•	•	•	•	•
Direct-reading precision flow gauge	•	•	•	•	•	•	•	•
Quick-change hose and handle assembly	•	•	•	•	•	•	•	•
200 watt airless welder element with ceramic core	•	•	•	•	•	•	•	•
550 watt air/nitrogen heating element	•	•	•	•	•	•	•	•
6066 Nitrocell Nitrogen Generator				•				•
Convenience Features								
Programmable start-up settings					•	•	•	•
Easily replaceable heating elements	•	•	•	•	•	•	•	•
Panel mounted circuit breaker					•	•	•	•
Panel mounted fuse	•	•	•	•				
Nitrogen bottle regulator and hose		•	•			•	•	
Air manifold for attachment of air hose			•	•			•	•
Welding rod and tool storage compartments			•	•			•	•
Welding rod organizer case (qty)	1	1	1	1	1	1	3	3

NITRO-FUZER® WELDERS | Features

INCLUDED Accessories	Analog				Digital			
	8000	8001	8002	8003	8200	8201	8202	8203
6145 Hand seamer tool			•	•			•	•
6482 Aluminum Tape			•	•			•	•
OPTIONAL Accessories (not included)								
6148 Bumper Rollers for dent removal	•	•	•	•	•	•	•	•
6146 Bumper Pliers Kit	•	•	•	•	•	•	•	•
6061 Nitrogen Welding System cover			•				•	
6061-1 Nitrogen Welding System cover				•				•
6074 Folding accessory shelf			•	•			•	•
Welding Rod (For a detailed list, visit www.polyvance.com)								
Urethane welding rod	•	•	•	•	•	•	•	•
15 feet each of PP, ABS, LDPE, TPO, PA, & 4 ft PC round rods	•	•	•	•	•	•		
Organizer case w/ five profiles of natural PP welding rod	•	•	•	•	•	•	•	•
Organizer case w/ five profiles of black PP welding rod							•	•
Organizer case w/ ABS, LDPE, TPO, PA, PC, & HDPE rods & ribbon							•	•
FiberFlex® welding rod and stainless steel wire mesh							•	•
5010-02 (3/32" thick) and 5010-03 (1/16" thick) polypropylene sheet							•	•
Construction								
Powder-coated, 16-gauge, USA-made steel cabinet	•	•	•	•	•	•	•	•
Sturdy cabinet-mounted torch holster	•	•	•	•	•	•	•	•
Fully-assembled, 16-gauge, USA-made welding cart							•	•
Oversized steel rivets throughout							•	•
Bolt-together, USA-made welding cart (assembly required)			•	•				
Safety								
Automatic low-pressure power cut-off protection	•	•	•	•	•	•	•	•
Shielded welder holster	•	•	•	•	•	•	•	•
Fully-grounded, enclosed welder cabinet	•	•	•	•	•	•	•	•
Adjustable nitrogen bottle supports			•				•	
Training								
Free unlimited access to Polyvance's online training library	•	•	•	•	•	•	•	•
Free unlimited phone tech support (7am-4pm CST Mon-Fri)	•	•	•	•	•	•	•	•
Free Polyvance plastic repair app	•	•	•	•	•	•	•	•
Available Polyvance I-CAR® Alliance training courses. Your location, our location, and on-line courses available.* (*Fees and/or student minimums may apply.)	•	•	•	•	•	•	•	•

Q.R. Codes For additional product information and pricing



Benefits of Plastic Welding:

- **Faster cycle time** - shops that increase their plastic repair percentage have experienced overall cycle time improvements of one to two days.
- **Higher gross profit** - shops make more money on labor than on replacement parts. Repair more plastics to keep more profit in the shop.
- **Lower severity** - shops that repair plastics can often find opportunities to increase their profits, while at the same time reduce the overall repair cost.
- **Strength** - fusion welding with the same material is stronger than bonding a different material.
- **Speed** - the welding process on thermoplastic can be finished much faster than two-part adhesive repairs.
- **Versatility** - nitrogen welding repairs tabs and small detail areas that would be impossible to do with two-part adhesives. It also allows you to repair polyethylene plastics like washer bottles and fender liners that two-parts won't stick to at all.
- **Avoid fit and blend issues** - repairing the OE cover allows you to blend in the panel rather than onto the undamaged fenders. It also avoids aftermarket fit issues.
- **Estimating options** - gives you more flexibility in the estimating process. Helps save total losses. Provides a bargaining tool with insurance adjusters.

Training:

Because Polyvance is an I-CAR Sustaining Partner™, students who successfully complete I-CAR Training Alliance approved training may redeem I-CAR credits at no additional cost. Call 800-633-3047 to register. (Available only in USA.)

Course Name	Description	Time Req'd	Location	I-CAR Training Alliance?	More Info & Pricing
PR-01 Introduction to Nitrogen Plastic Welding	Provides up to three technicians with hands-on experience in five essential plastic welding operations, including thermoset polyurethanes.	3 hours	At your location, 3 students max	Yes 3 hours	
PR-02 Two-Day Plastic Repair & Refinishing	Provides a complete understanding of the plastic bumper repair process, from heat shaping and dent removal to welding, filling, priming, and texturing.	2 days	At our facility in Rainsville, AL	Yes 13 hours	
PR-03 Headlight Repair	This one-hour, video-based, e-learning course will show you how to repair broken headlight tabs with the nitrogen plastic welding system.	1.5 hours	Online at polyvance.tortal.net	Yes 1 hour	
PR-04 One-Day Plastic Repair & Refinishing	Full day class, our instructor comes to you. Provides a complete understanding of the plastic bumper repair process, from heat shaping and dent removal to welding.	7 hours	At your location, 4 students max. Travel expenses apply.	Yes 7 hours	
EPR-01 Estimating Plastic Repair	Takes an estimator or technician with no prior experience through plastics ID, repair methods, and 30 different calibration exercises where bumper damage is rated on a scale of 1 to 5.	2 hours	Online at polyvance.tortal.net	Yes 2 hours	





THERMODRY TECHNOLOGY



CALL US TODAY

**FOR THE BEST
EQUIPMENT & SERVICE!**

(855) 999.SCCE

Walcom® USA

THERMODRY TECHNOLOGY



MULTIFUNCTION
HEAT CONDITIONER



MADE IN ITALY

The Thermodyr Technology system is based on 3 main functions:

AIR HEATING AND THERMOREGULATION
(TD3 PRO, TD1 PRO)

Compressed air used in paint booths is generally influenced by low temperatures in the winter and by high relative humidity the summer. Even with adequate booth heating or, in the summer, cooling dryers, temperature of the air entering the gun stock has a hard time reaching 75 °F. It should also be taken into account that air expansion causes temperature to drop an addition 50 °F - 54 °F, lowering paint atomization air to a temperature under 50 °F. With relative humidity under room temperature "dew point", a micro-mist that mixes with the paint may be generated. Therefore, the ideal 75 °F conditions indicated by paint manufacturers for satisfactory results are not met with consequent loss of brilliancy, orange peel effects and poor paint distribution.

The Walcom® Thermodyr Technology system heats and maintains the set air temperature regardless of climate/room conditions. The operator can set temperature from 68 °F - 122 °F for the painting phase and up to 158 °F for the drying phase. The PID retroaction system (proportional-integrated-derived) and instant regulation of the heating power at SCR (wave cut) keeps the temperature set by the operator constant. The IPH heating system has the same heating element features as the equipment, thus providing both tube heating and internal temperature control, keeping it constant during the entire paint cycle.

AIR FILTRATION
(TD3 PRO)

This fully removes solid and gaseous impurities from the compressed air output in 4 phases:

- separation from water with automatic drain
- separation of any oil traces with manual drain
- elimination of residual humidity with silica gel and output dew-point conditioning at values -30°cdp
- elimination of all impurity residue and the creation of breathable air with a carbon active filter.

AUTOMATIC DEHUMIDIFYING MASS REGENERATION
(TD3 PRO)

SRS regenerates silica gel in just 4 hours with the push of a button. This is achieved by reverting flow of heated air to temperatures suited to regenerate the dehumidifying mass. Equipment comes with a timer to automatically turn off the regenerative system after 4 hours and make it ready for operator's use

TD3 PRO

- 2 painters
- precise thermocontrol
- full filtration and drying
- silica regeneration



TD1 PRO

- 2 painters
- precise thermocontrol



IPH: 36 ft. - 50 ft. - 74 ft. galvanized rubber I Ox 15 air tube, anti-static finish, heated by an internal 1200 W resistance and complete with J thermocouple for temperature regulation. It rapidly reaches the set temperature and efficiently maintains it.

The Walcom ThermoDry systems thermoregulated air allows you to heat materials at the point of atomization within your spray gun nozzle free of gaseous impurities and humidity.

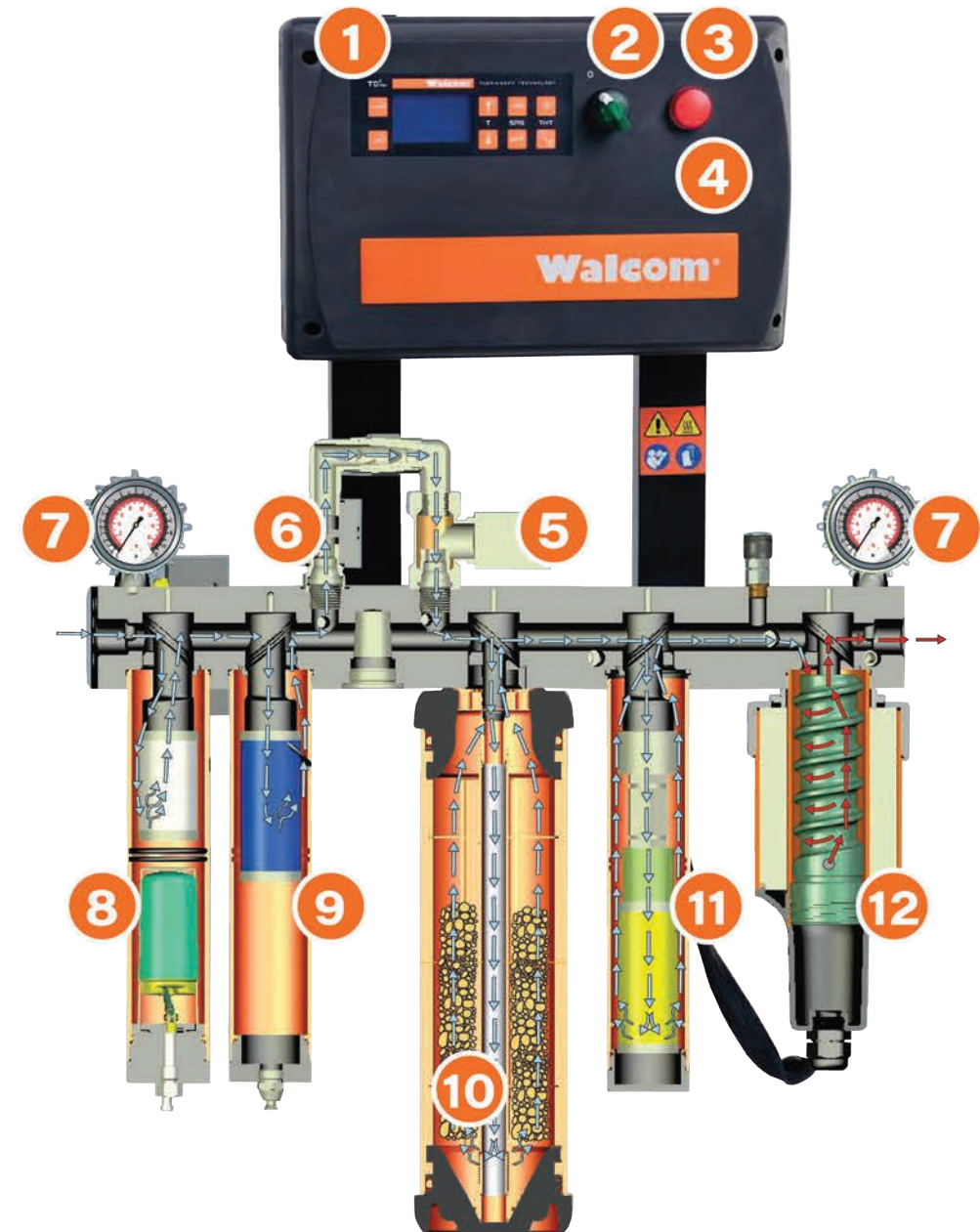

- 1 LCD Control & Display
- 2 On/Off Switch
- 3 Fault Indicator
- 4 PID Panel

- 5 Solenoid Valve SRS
- 6 Pressure Regulator
- 7 Pressure Gauge
- 8 Water Filter

- 9 Oil Filter
- 10 Silica Dehumidifier
- 11 Active Carbon Filter
- 12 Heater Element

SYSTEM BENEFITS

- Reduces drying time by 25% to 40% for waterborne and solvent based paints
- Saves up to 15% in materials due to higher transfer efficiency and maximum coverage
- Greatly cuts down on overspray due to superior atomization, and as a result extends spraybooth filters lifecycle
- Reduces cycle times and operating temperatures of your existing spraybooth, saving time and energy
- Considerably less time spent on buffing as a result of a clean paintwork
- Increases overall body shop efficiency by allowing more paint cycles a day/week

NEW SOFTWARE

The I.II version efficiently manages TD operations, controlling any system faults.

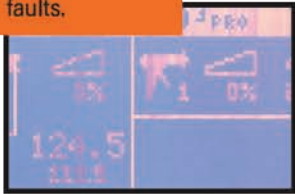

DOUBLED AIR FLOW

The 43 cfm air flow lets you use 2 spray guns simultaneously.



THT

New high performance hose with 1200 W power



DRAIN SYSTEM

Automatic for water with safety rod for any clogs; manual for oil



AC EQUIPMENT



CALL US TODAY

FOR THE BEST EQUIPMENT & SERVICE!

(855) 999.SCCE

MAXIMIZE YOUR PRODUCTIVITY AND PROFITABILITY

Efficiently Recover, Recycle and Recharge your customer's automotive A/C systems with machines that are built to last!

MX134 (R-134a)



MAXXAIR™ ADVANTAGES

Compatible with Electric and Traditional Engine-Driven Compressors

Heavy Duty Construction

- Durable welded steel frame
- Designed to withstand the harshest shop environments

10" Foam Filled Tires

- No flat, maintenance-free tires
- Larger tire diameter for greater mobility over shop floor obstacles

Patented Motor-Controlled Ball Valves

- Resists sticking and clogging
- Larger opening for increased flow

Patented Oilless Compressor

- Designed for high capacity industrial applications
- Increased service life over competitor oiled compressors
- Unique design enables recovery of liquid refrigerant

Removable Tank for Transport

- Eliminates the need for scale locks

Upgradeable to 50lb tank capacity for Large Capacity Systems

Providing the Industry's Best – MAXXAIR™ Warranty (1-2-3)



MX1234 (R-1234yf)

MAXXAIR™ Series by cps® Refrigerant Management Centers



FEATURES

- 7" Color touch screen control panel to allow quick access to all functions from the main screen
- Bluetooth/Wireless Adapters #TAC100 (Optional) that enable complete pre- and post-service health checks of the system
- Refrigerant Management System monitors filter life and refrigerant usage
- Two product configurations for:
 - R-134a
 - R-1234yf
- Supports multiple languages/UOM
- Hose management built into the handle assembly
- Includes vehicle data base for oil and refrigerant charging capacities
- Warranty: 1-year labor / 2-year parts / 3-year compressor

- 12.67cc Oil-less Compressor**
 - Designed and built by CPS for high capacity commercial applications
 - Eliminates failure issues due to improper oil filling of traditional compressors

Motor-Controlled Ball Valves

- Opens wider for greater flow
- Resistant to clogging of debris or sealants
- Faster recovery and tank fill for:

SPECIFICATIONS

- Thermal Printer (Optional)
- Wi-Fi printer capable
- Heater Blanket #CCXHB (Optional). Reduces recharge time in colder weather
- 30Lb Recovery tank
- Recovery rate = Up to 1 lb/min
- 2 CFM vacuum pump
- 3.5" gauges
- 10' power cord
- 10' hoses
- 115v, 850 W



MX1234 (R-1234yf)

Highlighted Features

1. Touch-screen LCD Display
2. High-side Gauge (Analog)
3. Low-side Gauge (Analog)
4. Storage for Small Tools or Fittings
5. 4" Total Locking Swivel Casters
6. 10" Foam-Filled Wheels

7" TOUCH SCREEN DISPLAY

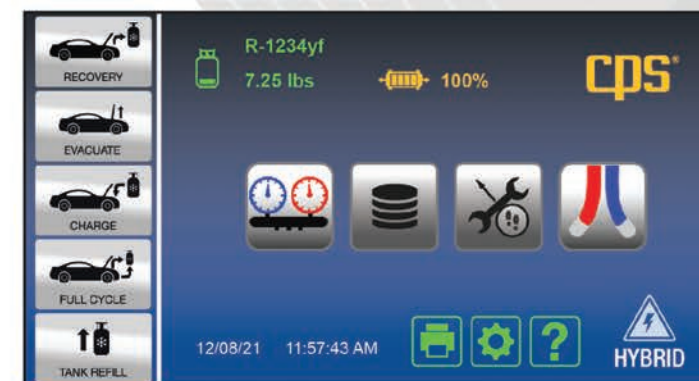

Home Screen features 5 Selectable Functions along with touch keys and information icons.

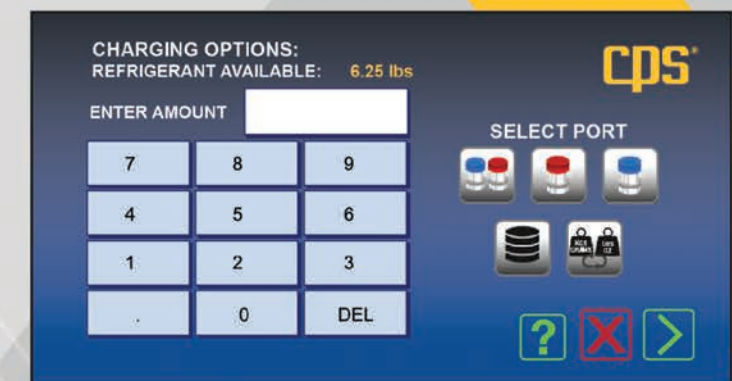

Refrigerant Charging Screen with interactive touch pad and port selection, database, and change UOM touch keys.

Part Number	Refrigerant	Dimensions				UPC	HTC
		H (in)	W (in)	D (in)	Weight (lbs)		
MX134	R134	44	23	28	208	750377120299	8415.83.0090
MX1234	R1234	44	23	28	208	750377120305	8415.83.0090



MAXXIMIZED PRODUCTIVITY AND VALUE BUILT INTO ONE MACHINE

Efficiently Recover, Recycle, and Recharge your Customer's Automotive A/C Systems with a unit that can serve ALL refrigerant types. If you're considering 1234yf units, get the best of both worlds with the MX3030!

MX3030 (R-134a/R-1234yf)



MAXXAIR™ ADVANTAGES

Compatible with Electric and Traditional Engine-Driven Compressors

Heavy Duty Construction

- Durable welded steel frame
- Designed to withstand the harshest shop environments

10" Foam Filled Tires

- No flat, maintenance-free tires
- Larger tire diameter for greater mobility over shop floor obstacles

Patented Motor-Controlled Ball Valves

- Resists sticking and clogging
- Larger opening for increased flow

Patented Oilless Compressor

- Designed for high capacity applications
- Increased service life over competitor oiled compressors
- Unique design enables recovery of liquid refrigerant

Removable Tank for Transport

- Eliminates the need for scale locks
- Includes two (2) 30Lb tanks and hose sets

Providing the Industry's Best – MAXXAIR™ Warranty (1-2-3)

SAE J3030 Certification

YOUR SINGLE MACHINE OPTION!



MX3030 (R-134a/R-1234yf)

Highlighted Features

1. Touch-screen LCD Display
2. High-side Gauge (Analog)
3. Low-side Gauge (Analog)
4. Storage for Small Tools or Fittings
5. 4" Total Locking Swivel Casters
6. 10" Foam-Filled Wheels

7" TOUCH SCREEN DISPLAY

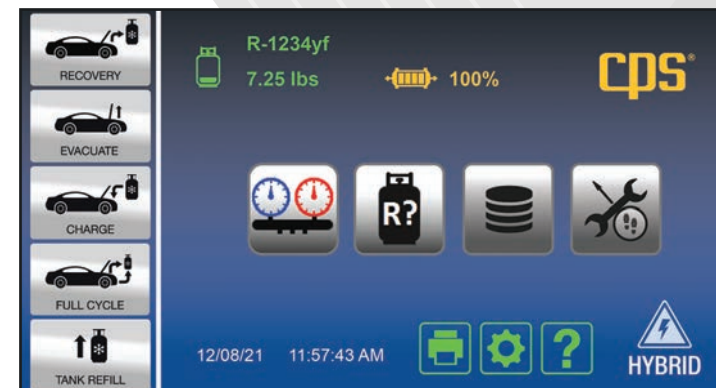

MX3030 Home Screen features 5 Selectable Functions along with touch keys and information icons.

FEATURES

- 7" Color touch screen control panel to allow quick access to all functions from the main screen
- Bluetooth/Wireless Adapters #TAC1100 (Optional) that enable complete pre- and post-service health checks of the system
- Refrigerant Management System monitors filter life and refrigerant usage
- One machine covers both R-134a and R-1234yf
- Includes Refrigerant ID
- Conversion between refrigerants can be done in approximately 10 minutes
- Supports multiple languages/UOM
- Hose management built into the handle assembly
- Includes vehicle database for oil and refrigerant charging capacities
- Warranty: 1-year labor / 2-year parts / 3-year compressor

12.67cc (2/3 hp) Oilless Compressor

- Designed and built by CPS for high capacity commercial applications
- Eliminates failure issues due to improper oil filling of traditional compressors

Motor-Controlled Ball Valves

- Opens wider for greater flow
- Resistant to clogging of debris or sealants
- Faster recovery and tank fill

SPECIFICATIONS

- Thermal Printer (Optional)
- Wi-Fi printer capable
- Heater Blanket #CCXHB (Optional). Reduces recharge time in colder weather
- Dual 30Lb tanks
- Recovery rate = Up to 1 lb/min
- 2 CFM vacuum pump
- 3.5" gauges
- 10' power cord
- 10' hoses
- 115v, 850 W



Refrigerant Change Screen: select Refrigerant Change key (highlighted) and follow onscreen instructions to change refrigerant.

Part Number	Certification	Refrigerant	Dimensions				UPC	HTC
			H (in)	W (in)	D (in)	Weight (lbs)		
MX3030	SAE J3030	R134a/R1234yf	44	23	28	233	750377120312	8415.83.0090



LIFTS



CALL US TODAY

FOR THE BEST EQUIPMENT & SERVICE!

(855) 999.SCCE



ENGINEERED TO PERFORM. BUILT TO LAST.

Reliable lift systems for independent repair shops, car dealerships, bodyshops, home enthusiasts, and heavy-duty truck facilities.

I-10 LIGHT DUTY TWO POST LIFT 10,000 lbs. Capacity

FEATURES:

Symmetrical column design
Spot-Rite™ 3-stage front arm design - spot vehicles asymmetrically or symmetrically

- Top mounted Direct-Pull lifting technology
- Cylinder rod concealed inside carriage
- Adjustable width options
- Single point lock release
- Powder coated finish
- Includes adapter storage bracket
- ALI Certified



INCLUDES LOW-PROFILE THREADED ADAPTERS AND (4 each) ADAPTER EXTENSIONS AT 3.5" and 5"



Spot-Rite™ 3-Stage Front Arm Design

accommodates vehicle spotting both symmetrically and asymmetrically. Position the vehicle doors in front of or behind the lift columns to prevent door damage and allow easy technician access!

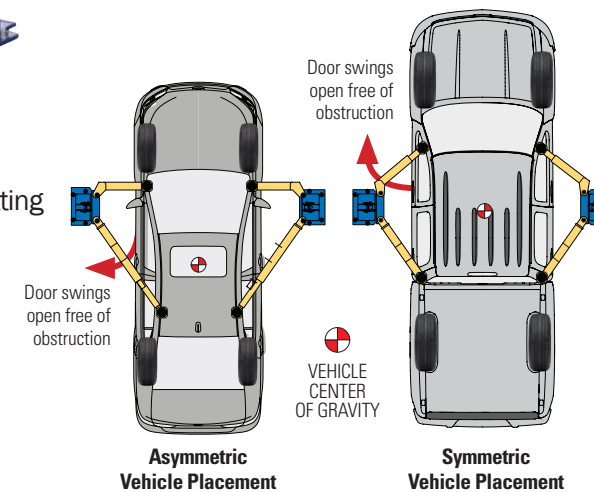

Lit# Forward i10 CUTSHEET.2021.06 ©2021 Vehicle Service Group™ All rights reserved. Unless otherwise indicated, Forward Lift, Vehicle Service Group™, Dover and all other trademarks are property of Dover Corporation and its affiliates. Printed in the U.S.A.

SPECIFICATIONS	I10N400MBL/RD*
Capacity	10,000 lbs. (4535kg)
Maximum rise	76 -1/4" (1937mm) w/5" extension
Overall Height	143" (3632mm)
Overall Width	131" or optional 137" (3327mm/4380mm)
Drive through clearance	99" (2515mm) or optional 105" (2667mm)
Overhead switch height	137-5/8" (3496mm)
Front reach (Min/Max)	23" / 44-3/8" (584mm/1127mm)
Rear reach (Min/Max)	36" / 58" (914mm/1473mm)
Min/Max adapter height	3-3/4" (95mm) w/o adapter extension 8-3/4" (222mm) w/ 5" adapter extension
Width inside column	109" or optional 115" (2769mm/2921mm)
Voltage/ Amps	208V/230V, 17 amps
Motor/Phase	1ph/2HP/60Hz
Ceiling height required	144" (3658mm)

*Lifts available in blue and red. Specifications subject to change without notice or liability.



ENGINEERED TO PERFORM. BUILT TO LAST.

Reliable lift systems for independent repair shops, car dealerships, bodyshops, home enthusiasts, and heavy-duty truck facilities.

Double your parking space instantly - perfect for the home enthusiast

EFP8

LIGHT DUTY FOUR POST LIFT
8,000 lbs. Capacity



72" LIFTING HEIGHT

68" CLEARANCE UNDER RUNWAYS



FEATURES:

Commercial grade lifts. Perfect for home use

- Exclusive adjustable lock ladder system
- Multi-position locks allow runways to be level at any lock position
- Single point lock release
- Powder coat finish
- Lifts available in black only

INCLUDES:

- Steel approach ramps
- Wheel caster kit
- Jack tray
- Drip trays



Poly caster kit

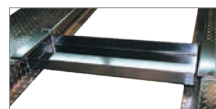

Jack tray



Drip trays

SPECIFICATIONS EFP8P000M

Capacity	8,000 lbs. (3628kg)
Rise	72" (1828mm)
Overall length with approach ramps	207-1/2" (5270mm)
Overall length without approach ramps	175-1/2" (4457mm)
Overall width without motor	103-1/2" (2628mm)
Approach ramp length	32" (812mm)
Runway width	18-1/2" (469mm)
Runway length	169-1/2" (4305mm)
Runway height	4-1/2" (114mm)
Height of columns	81-1/2" (2070mm)
Clearance between columns	94" (2387mm)
Clearance between runways	38" (965mm)
Outside runway to outside runway	74" (1879mm)
Clearance under runway	68" (1727mm)
Motor	115VAC, 1HP

Lifts available in black only
Specifications subject to change without notice or liability.



EFP9

LIGHT DUTY FOUR POST LIFT
9,000 lbs. CAPACITY

Includes 20" wide runways for wider vehicles!

84" MAXIMUM RISE

79 1/4" CLEARANCE UNDER RUNWAYS



Commercial grade lift - perfect for the shop or home use.
Double your parking space instantly!

FEATURES:

- Exclusive Adjustable Lock Ladder Leveling System to enable level runways at all lock heights - even on uneven floors
- Multiple height lock positions to work at a comfortable height or store a vehicle at a height that works with your ceiling height
- Operate the lift from one column with the Power Unit and single point lock release
- Power unit and lock release can be mounted to any column that works best for your garage
- Steel approach ramps • Durable black powder coat finish
- Powered with standard 115V plug included

INCLUDES:

- Wheel Caster Kit
- Jack Tray
- Drip Trays

Includes one (1) 4,000 lbs. capacity Jack Tray



Includes four (4) Poly Casters



Includes four (4) Drip Trays

OPTIONAL ACCESSORIES:

- **RRJ45** / 4,500 lbs. capacity hydraulic hand pump Rolling Jack
- **90° power unit bracket** moves power unit to the front of column for additional space.

CAN FOUR POST LIFTS FIT IN MY SHOP OR GARAGE?

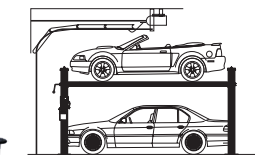

To determine the space requirements needed for your four-post lift, scan this code or go to www.forwardlift.com and click on **CEILING HEIGHT CALCULATOR**.

ALI GOLD CERTIFIED

Forward Lift EFP9 meets the highest industry safety and performance standards. Your assurance of certification is the gold ALI/ETL certified label.

SPECIFICATIONS EFP9P000MBK

Capacity	9,000 lbs.
Maximum Rise	84"
Clearance Under Runway	79 1/4"
Overall Length with Approach Ramps	18' 9 1/2"
Overall Length without Approach Ramps	16' 1 1/8"
Overall Width with Motor	11' 1/2"
Overall Width without Motor	10' 1 1/2"
Approach Ramp Length	37"
Runway Width	20"
Runway Length	184 1/2"
Runway Height	4 3/4"
Drive Thru Width	97"
Column Height	8' 1"
Clearance Between Columns	109 1/2"
Clearance Between Runways	39"
Outside Runway to Outside Runway	79"
Motor	115VAC, 1HP

Lifts available in black only
Specifications subject to change without notice or liability.





GLUE PULLING



CALL US TODAY

**FOR THE BEST
EQUIPMENT & SERVICE!**

(855) 999.SCCE



SPEEDLINE GLUE SYSTEM

ADVANCED REPAIR EQUIPMENT FOR THE TECHNICIAN'S TOOLBOX

The Glue Repair section of BETAG's outer panel repair toolbox contains a range of advanced equipment designed to enable technicians to work precisely and efficiently.

Glue has a wide range of applications across steel and aluminum panel repair. It can be used as a less invasive repair method in isolation for smaller damage – and is a quick and easy means of significantly reducing or completely repairing larger damage, particularly when used in combination with some of BETAG's other repair tools and techniques.

DESCRIPTION

- Speedline system is available in Eco, Business and Pro versions
- Can be configured as a single comprehensive system or several satellite systems



SPEEDLINE ACCESSORY KIT

IS A GREAT SUPPLEMENT TO ANY BRIDGE SYSTEM, LIKE THE FLATLINER.

With the addition of this kit, you can use the existing system on any glue panel repair. It has a large selection of Speedlines, Pull Knobs, and Pulling Element attachments.

SPECIFICATIONS

Parts/Accessories:

- 2 X Speedline Pack
- Speedline Pulling Element S
- Speedline Pulling Element SM
- Speedline Pulling Element M
- 5 x Speedline Bit M6
- 5 x Pull Knob Round
- 5 x Pull Knob Big Round
- 5 x Pull Knob Flat
- 5 x Pull Knob Big Flat
- 5 x Pull Knob GT15
- 5 x Pull Knob GT25
- 5 x Pull Knob HT15
- 5 x Pull Knob HT 20
- 5 x Pull Knob HT30
- Power Knob Set
- Beige Glue
- Blue Glue
- Speedline Bridge Adaptor



SPEEDLINE ECO SYSTEM

IT'S QUICK AND EASY USE MAKES IT IDEAL FOR ANY TECHNICIAN.

The Speedline Eco System is a versatile bridge pulling system for quick glue panel repairs.

SPECIFICATIONS

Parts/Accessories:

- S-Bridge
- Speedline 8
- Speedline 16
- Speedline 24
- Pulling Bar
- Speedline Pulling Element S
- Speedline Pulling Element SM
- Speedline Pulling Element M
- Beige Glue
- Blue Glue
- Speedline Bridge Adaptor



SPEEDLINE PRO STATION

PROVIDES A WIDE RANGE OF TOOLS TO TACKLE ANY GLUE PANEL REPAIR.

The Speedline Kit, which contains the Speedline Puller, and a wide range of Speedline tabs. The Accessory Kit has a large selection of both large and small tabs, and a wide range of Pulling Elements. Two bridges are also included, with the Business for larger areas, aided by adjustable feet, and the Eco Bridge, which is ideal for medium panel and quick applications.

SPECIFICATIONS

Parts/Accessories:

- Dentliner
- Speedline Set
- Speedline Accessory Set
- Speedline S-Bridge
- Edge Lifter
- Speedline FL Hammer
- Small Trolley



SPARE GLUE PARTS



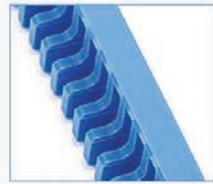

Speedline 8

(4420)

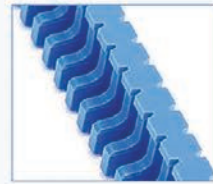

Speedline 8R

(4421)

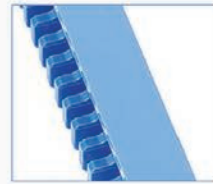

Speedline 16

(4422)



Speedline 16R

(4423)



Speedline 24

(4424)



Speedline 24R

(4425)



Speedline Pulling Element S (18mm)

(4430)



Speedline Pulling Element SM (40mm)

(4431)



Speedline Pulling Element M (80mm)

(4432)



Speedline Pulling Element L (140mm)

(4433)

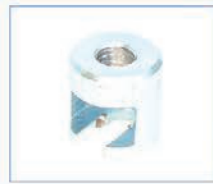

Speedline Bridge Adaptor

(4452)



PE-Bottle - 250ml

(9902)



Pullmelt 6 Beige Glue

(7535)



Pullmelt 8 Green Glue

(7538)



Pullmelt 7 Blue Glue

(7530)



Pull Knob Small Round

(7511)



Pull Knob Big Round

(7512)



Pull Knob GT-15

(7515)



Pull Knob GT-25

(7516)



Pull Knob HT-15

(7517)



Pull Knob HT-20

(7518)



Pull Knob HT-30

(7519)



Pull Knob Small Flat

(7521)



Pull Knob Big Flat

(7522)



Power Knob Full Set

(4000)



Glue Gun 220V/EU

(7550)



Glue Gun 220V/AU

(7551)



Glue Gun 120V/US

(7552)



Glue Gun 12V

(7553)



Glue Gun 110V/JP

(7555)



Knock Down

(7540)



Window Wedge

(8101)



Power Knob Set Basic - without Bits

(7526)



Power Knob Set Bit - with Bits

(7527)



Power Knob M6

(7525)



Speedline Bit M6 (10mm)

(4434)



Hammer

(7570)



southerncaliforniacollisionequipment.com

(855) 999.SCCE