

Chief Tool Board Packages feature the most innovative tools for repair of today's vehicles. These pulling accessories are available in various configurations, offering maximum versatility to keep pace with the evolution of automotive design.

Structural Holding Package 300001

Part #128 - 300001 Weight: 555 lbs. (252 kg)

The Structural Holding Package is designed to give additional holding to newer vehicles manufactured with large amounts of High Strength and Ultra High Strength steels and additional Aluminum structures.

Structural holding allows a technician to apply additional holds, spreading out the amount of pressure at each hold location reducing the chance of additional damage during repairs. This holding is necessary to hold a part being replaced in the correct location for welding and bonding.

This system will fit any Chief or Chief style machines with rectangle holes on top of the deck. This concept allows a shop that has an older machine to be equipped with the latest technology in holding systems that will assist in repairs on the newest vehicles.

This Structural Holding Package is conveniently mounted on a tool board that outlines each component making it simple to identify where the part goes; all of this affixed to an easy-to-roll cart designed for the technician's convenience and a clean looking shop.

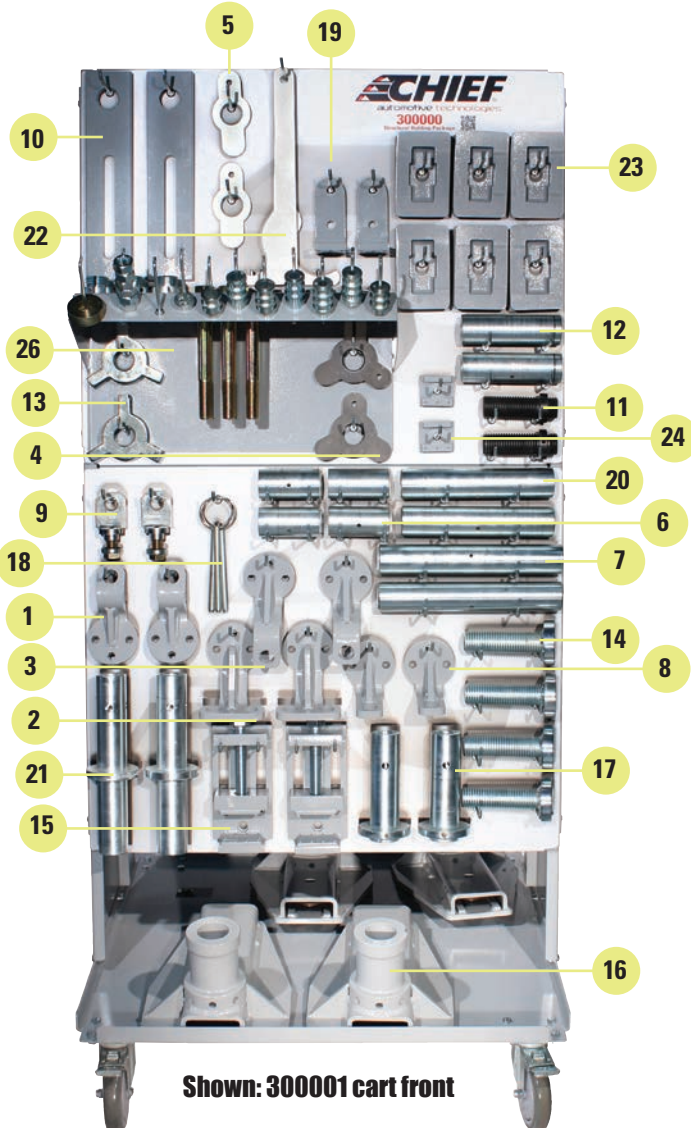

Shown: 300001 cart front

No.	Part No.	Qty.	Description
1	502000	2	Vertical Fixture Short
2	502005	2	Horizontal Fixture Large
3	502008	2	Vertical Fixture Tall
4	502014	2	Wing Nut, Parts Holding - LH
5	502015	4	Wing Nut, Parts Holding - RH
6	502016	4	4" Extension Tub
7	502017	2	12" Extension Tub
8	502019	2	Tall Horizontal Fixture
9	502026	2	Angle Adaptor Clamp Ass'y
10	502031	2	Base Plate
11	502033	2	Adapter, Parts Holding Lower
12	502034	2	Center Tub Parts Holding Turn Buckle
13	502038	2	Rigging Nut
14	502039	4	Structural Holding Adapter Ass'y
15	502042	2	Structural Vise Ass'y
16	502047	4	Structural Parts Holding Base
17	502055	2	Short Tub Base Stand Ass'y
18	502058	4	Release Pin Ass'y
19	502060	2	Wrist Block
20	502061	2	10" Extension Tub
21	502063	2	Tall Tube Base Stand Ass'y
22	502067	1	Spanner Wrench Ass'y
22	502069	1	Spanner Wrench Ass'y
23	607371	6	Fastener Plate, UAS
24	638133	2	Jaw Clamp Ass'y
25	611311Y	2	Parts Holding Arm (on cart back)
26	502062	1	Bolt Tray, Structural Holding

Structural Holding Package 300001

Part #128 - 300001 Weight: 555 lbs. (252 kg)



Shown: 300001 cart back

The parts holding arm allows for quick and easy set-up giving the technician the ability to adjust in all directions from any hole on the deck.



Part #611311Y / Parts Holding Arm

Vertical fixtures can mount to locations such as the suspension mounting areas creating a very strong hold for structural repairs.



The large horizontal fixture allows the ability to hold and control the end of a rail or structure for alignment or replacement of that component.



The structural holding package can be used to make **eight point holding** where needed with suspension in or out.



The system can be used for **Unitized and Full Frame vehicles** utilizing the vise clamp to hold full frame rails.

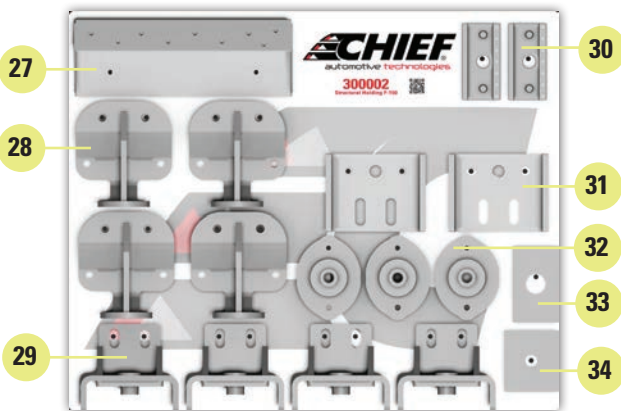
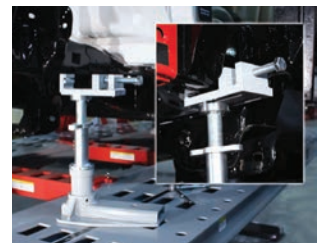

The **F150 Tool Board** allows three ways to create holds for repairs:

The **Rigid Cab Mounts** are used to replace the rubber factory cab mounts during structural repairs.

Additional holds can be made when using the **90° Angle Pinch-Weld Jaws** that mount to the rocker flange inconjunction with the FAST Anchoring system.

A third method of holding is using the **Running Board Fixture** in conjunction with the base and fixture extensions within this parts package.

For additional kits for these brands and more, contact us!



No.	Part No.	Qty.	Description
27	502070	1	Bolt Tray, Structural Holding, F150
28	640114	4	F150 Running Board Bracket Ass'y
29	640004	4	Weldment, Pinch-weld Base, F150
30	498110	4	Pinch Jaw with Nails Complete
31	640076	4	Formed Vertical Clamp, F150
32	640120	6	Weldment, Cab Mount, F150
33	640100	6	Support Plate, Cab Mount, F150
34	682953	4	Plate, EZ-Liner Tie Bolt